

Operation Manual

INKJET PRINTER
UJ330H-160

Operation Manual

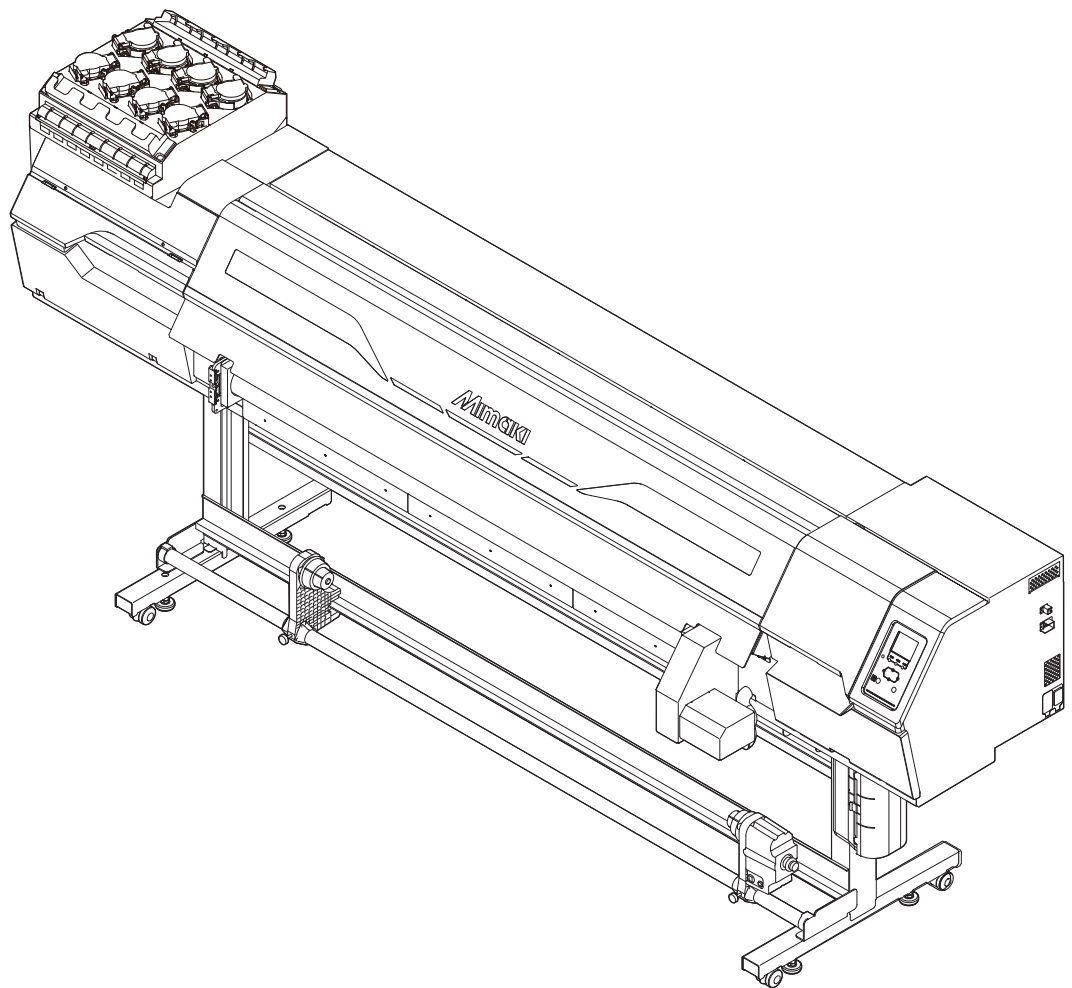

You can also download the latest manual from official website.

MIMAKI ENGINEERING CO., LTD.

<https://mimaki.com/>

D203896-13
Original instructions

TABLE OF CONTENTS

Introduction	6
To Ensure Safe Use	8
Symbol Marks	8
Usage Precautions	9
Prohibited Dangerous Actions	13
Usage Restrictions.....	15
Connecting the Power	17
Notes on Handling Ink or any Other Liquid Used with the Machine	18
Ink Specifications.....	20
Restrictions Concerning the Expiration Date of Ink Used in the Machine	21
Installation Precautions.....	22
Installation Space	23
When relocating the machine	23
Safety Interlocks	24
Warning Label.....	25

Chapter 1 Before Use

1.1 Part Names and Functions	30
Front	30
Rear and Right Side View.....	32
Positioning Bar and Rear Clamp Roller	33
Ink Supply Unit.....	34
Carriage	35
Station.....	35
Print Area (Platen)	35
Media Sensor.....	36
Power Supply Switch	37
Operating Panel.....	38
1.2 Connecting the Power Cable	41
Turning On the Power.....	41
Turning Off the Power.....	42
1.3 Connecting a PC to the Product	44
Using a LAN Cable	44
Using a USB Cable.....	45
1.4 System Configuration	46
Installing the Mimaki Driver.....	47
Installing RIP Software	47
Obtaining Color Profiles.....	47
Setting Up RIP Software.....	47
1.5 Ink Replacement Method.....	49
When Ink Near End is Displayed	49
When Ink End is Displayed.....	49
Replacing Ink	50

Chapter 2 Printing

2.1 Print Process	58
2.2 Adjusting Print Head Height.....	60
2.3 Loading the Media	62
Media	62
Media Feeding Belt.....	63
Take-up unit.....	64
Feeding unit	66
Loading the Roll Media	68
Loading Rigid Media	72
Resetting the media.....	81
Registering the Media	83
2.4 Test Printing.....	87
Changing the Layout Direction for Test Printing	87
Checking White Ink Ejection	88
Ejection Failures	88
2.5 Head Cleaning	89
2.6 Auto-correction	90
2.7 Feed Correction	92
Feed Correction Procedure	92
2.8 Correcting the Drop Position.....	94
Drop Position Correction Procedure	94
2.9 Preparing RIP data	96
2.10 Printing.....	98
Changing the origin.....	98
Starting Printing	99
Stopping Printing (Data Clear).....	100
Eject the rigid media	101
2.11 Pullback printing	102
When using pullback printing for register marks.....	102
If Mark Detection Fails	103
2.12 About 2.5D printing	105

Chapter 3 Setup

3.1 Media Setting Menu.....	108
3.2 Maintenance Menu	112
Registering Nozzle Recovery	114
Nozzle Check.....	116
Cap Suction Check	116
3.3 Function Setting Menu.....	118
3.4 Environment Setting Menu	120
3.5 Machine Status Menu	122

Chapter 4 Maintenance

4.1 Maintenance Precautions	124
-----------------------------------	-----

4.2 Maintenance Methods	125
Maintenance Items and Timing.....	125
Ink Maintenance	126
Cap Rubber Cleaning	127
Carriage Underside Cleaning	127
Cloth Wiper Area Cleaning	129
NCU Cleaning.....	130
DAS (Automatic Correction Function) Sensor Cleaning	131
Ink Discharge Channel Cleaning	132
Media Sensor Cleaning	132
Jam Sensor Detecting Plate Cleaning	133
Media Feeding Belt Cleaning.....	134
Checking State of Media Feeding Belt Edges	134
Cover (Exterior) Cleaning	136
Cleaning the Mist Filter	137
When this Printer is Left Unused for a Long Time	139
4.3 Replacement of Consumable Item	141
Consumable Item Replacement Timing.....	141
Cloth Wiper Replacement.....	142
Cap Replacement	146
Replacing the Absorber Around the Station	148
Waste Ink Tank Replacement.....	150
Mist Filter Replacement	153
UV-LED Glass Replacement	154
Ink Bottle Cap Replacement	155

Chapter 5 Troubleshooting

5.1 Troubleshooting	158
The power does not turn on.....	158
Printing is not possible.....	158
The media jams or the media is dirty.....	158
Trouble with the Media Feeding Belt	159
Image defects occur.	161
The ink has leaked out.....	166
The light-blocking cover comes off.	166
Abnormal noise occurs during cleaning.....	167
5.2 To Stop Circulation Operation	168
5.3 Problems Causing Messages to Appear	169
Warning Messages	169
Ink Error	170
Error Message	171
SYSTEM HALT	180

Chapter 6 Appendix

6.1 Specifications.....	182
-------------------------	-----

6.2 Options	186
Options List.....	186
Ionizer	186
Roller Table Assy.....	189
6.3 LICENSE Library	196

Introduction

Thank you for purchasing the Inkjet printer UJ330H-160.

Read this operating manual ("this document" hereinafter) thoroughly and make sure you understand its contents to ensure safe and correct use of the product.

Please note that the illustrations contained in this manual are intended to show functions, procedures, or operations and may sometimes differ slightly from the actual machine.

Adobe, the Adobe logo, Acrobat, Illustrator, Photoshop, and PostScript are the trademarks or registered trademarks of Adobe Incorporated in the United States and other countries.

Other company and product names mentioned herein are the trademarks or registered trademarks of the respective companies in Japan and in other countries.

Unauthorized reproduction of any portion of this document is strictly prohibited.

© 2026 MIMAKI ENGINEERING Co., Ltd.

● DISCLAIMERS

- MIMAKI ENGINEERING REJECTS ALL LIABILITY FOR DAMAGE ARISING DIRECTLY OR INDIRECTLY FROM THE USE OF THE UJ330H-160 ("THIS MACHINE" HEREINAFTER), WHETHER OR NOT THE PRODUCT IS FAULTY.
- MIMAKI ENGINEERING REJECTS ALL LIABILITY FOR DAMAGE, DIRECT OR INDIRECT, TO MATERIALS CREATED WHILE USING THIS MACHINE.
- USING THIS MACHINE IN CONJUNCTION WITH DEVICES OTHER THAN THOSE RECOMMENDED BY MIMAKI ENGINEERING MAY RESULT IN FIRE OR ACCIDENTS. SUCH INCIDENTS ARE NOT COVERED BY THE PRODUCT WARRANTY. MIMAKI ENGINEERING REJECTS ALL LIABILITY FOR DAMAGE, DIRECT OR INDIRECT, ARISING FROM SUCH INCIDENTS.
- USE ONLY GENUINE MIMAKI ENGINEERING INK AND MAINTENANCE LIQUID. USE OF OTHER PRODUCTS MAY RESULT IN FAILURES OR REDUCE PRINT QUALITY. SUCH INCIDENTS ARE NOT COVERED BY THE PRODUCT WARRANTY. MIMAKI ENGINEERING REJECTS ALL LIABILITY FOR DAMAGE, DIRECT OR INDIRECT, ARISING FROM SUCH INCIDENTS.
- DO NOT ATTEMPT TO REFILL THE INK BOTTLES WITH UNAUTHORIZED INK. SUCH INCIDENTS ARE NOT COVERED BY THE PRODUCT WARRANTY. MIMAKI ENGINEERING REJECTS ALL LIABILITY FOR DAMAGE, DIRECT OR INDIRECT, ARISING FROM SUCH INCIDENTS.
- AVOID USING UV-LED UNITS OR UV POWER SUPPLY UNITS OTHER THAN THOSE SPECIFIED BY MIMAKI ENGINEERING. USING DEVICES OTHER THAN GENUINE MIMAKI ENGINEERING DEVICES MAY RESULT IN FAILURE, ELECTRIC SHOCK, OR FIRE. SUCH INCIDENTS ARE NOT COVERED BY THE PRODUCT WARRANTY. MIMAKI ENGINEERING REJECTS ALL LIABILITY FOR DAMAGE, DIRECT OR INDIRECT, ARISING FROM SUCH INCIDENTS.

● TV and radio interference



- The machine emits high-frequency electromagnetic radiation while operating. Under certain circumstances, this may result in TV or radio interference. We make no guarantee that this machine will not affect special radio or TV equipment.
-

If radio or TV interference occurs, check the radio or TV reception after turning off the machine. If the interference disappears when the power is turned off, the machine is likely to be the cause of the interference.

Try any of the following solutions or combinations of these solutions:

- Change the orientation of the TV or radio antenna to find a position where interference does not occur.
- Move the TV or radio away from this machine.
- Plug the TV or radio into a power outlet on a power circuit other than the power circuit to which this machine is connected.

● FCC (Federal Communications Commission) regulations

The machine has been tested and certified to comply with restrictions applying to Class A digital devices under Part 15 of the FCC regulations. These restrictions are designed to provide suitable protection from harmful interference when the printer is used in commercial environments.

This product may generate, use, or emit radio frequency energy and may cause harmful interference with radio communications if not installed or used in accordance with the operating manual.

Use of this product in residential areas may cause harmful interference. If so, the user is responsible for rectifying such interference.











- Use only the cables recommended by Mimaki Engineering when connecting to the machine. Use of other cables may cause the product to exceed the restrictions stipulated by FCC regulations. To maintain compliance with FCC regulations, use the cables recommended by Mimaki Engineering.
-

To Ensure Safe Use

Symbol Marks

This document uses symbol marks to explain precautions when operating the machine. Make sure you fully understand the meaning of each mark to ensure safe and correct use of the machine.

Explanation		
	Warning	Indicates a potential hazard that may result in death or serious injury if handled improperly or if instructions are disregarded.
	Caution	Indicates a potential hazard that may result in minor or moderate injury if handled improperly or if instructions are disregarded.
	Notice	Indicates a potential hazard that may result in property damage if handled improperly or if instructions are disregarded.
	Warning sign	Indicates something that requires attention. Warning specifics are drawn inside the symbol.
	Mandatory action sign	Indicates an action that must be carried out. The specifics of the mandatory action are drawn inside the symbol.
	Prohibition sign	Indicates a prohibited action. The specifics of the prohibited action are drawn inside the symbol.
	Important	Indicates important information related to use of this machine.
	Tip	Indicates useful reference information.
	Reference information	Indicates the corresponding page for related information.

Usage Precautions

● In the event of abnormal conditions

WARNING



- In the event of abnormal conditions such as smoke or unusual odor, turn off the main power immediately and unplug the power cable. Continuing to use the machine under these conditions may result in failure, electric shock, or fire. Once you have confirmed that smoke is no longer being emitted, contact your local dealer or our service office. Never attempt to repair the machine yourself, which is hazardous.

CAUTION



- Immediately wipe off any ink, maintenance liquid, waste ink, or other liquid used with the product that comes into contact with your skin. Then wash using soap, and rinse with plenty of water. Failure to wash off ink may result in skin inflammation. If your skin becomes irritated or painful, seek medical attention immediately.
- If ink, maintenance liquid, waste ink, or any other liquid used in the product comes into contact with your eyes, rinse immediately with plenty of clean water. Rinse for at least 15 minutes. If you are wearing contact lenses and can remove them easily, rinse them under clean running water for at least 15 minutes before removing them. Be sure to also rinse the undersides of your eyelids. Failure to rinse off ink may result in blindness or impaired vision. If your eyes become irritated or painful, seek medical attention immediately.
- If ink, maintenance liquid, waste ink, or any other liquid used in the product enters your mouth or is swallowed, gargle with water immediately. Do not induce vomiting. Seek medical attention promptly. Inducing vomiting may cause liquid to enter the airway.
- If a large amount of vapor is inhaled, move to a well-ventilated area, keep warm, and rest in a posture that allows easy breathing. If the condition does not improve, seek medical attention promptly.

NOTICE



- If an ink leak occurs, turn off the main power immediately and unplug the power cable. Then, contact your local dealer or our service office.

● Power supply precautions

⚠ WARNING



- Use the power cable provided. Otherwise there is a risk of failure, electric shock, or fire. The power cable provided is exclusive for the machine, and must not be used for other electrical equipment.
- Always hold the plug when removing the power cable. Pulling out the power cable may damage the cable, leading to failure, electric shock, or fire.
- Do not use the machine with dust accumulated on the power plug. Otherwise there is a risk of failure, electric shock, or fire.
- Take care to prevent metals from touching the power plug blades. Otherwise there is a risk of failure, electric shock, or fire.
- Do not damage or modify the power cable. Do not place heavy objects on, heat or stretch it. Doing so may damage the cable, leading to electric shock or fire.
- Do not use extension cords or power strips. Otherwise there is a risk of failure, electric shock, or fire.
- Do not use the power cable if it is damaged or broken or if the core wire is exposed. Otherwise there is a risk of failure, electric shock, or fire.
- Do not handle the power plug with wet hands. Disregarding this precaution may result in electric shock.



- Plug the power cable plug into a grounded power outlet. Otherwise there is a risk of failure, electric shock, or fire.
- When installing electrical outlets, perform grounding work to prevent electric shock. All electrical work (Class C grounding work; formerly Type 3 grounding work) must be handled by a licensed electrician.

NOTICE



- Do not turn off the main power supply. Turning off the main power supply will disable the automatic maintenance function (including nozzle clogging prevention function and ink discharge channel cleaning function). This increases the risk of ejection failures (such as nozzle clogging or deflection).

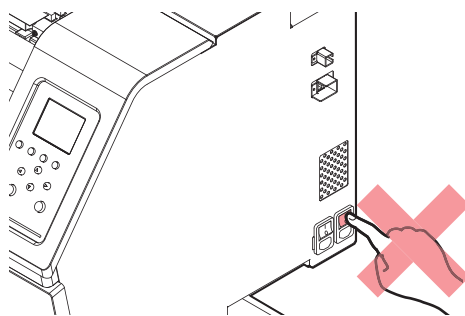

- Use the machine with a power supply that meets specifications.
- Be sure to plug the power cable into a power outlet close to the machine. Insert the power plug blade securely.
- When connecting the power cable, check the input voltage of the power outlet and the capacity of the breaker. Also, connect each cable to a separate power source with an independent breaker. Connecting to power outlets linked with the same breaker will cause the breaker to trip.

● Caution regarding moving parts

CAUTION



- Keep parts of the body such as the face and hands away from moving parts. Also keep clothing (e.g., loose clothing and accessories) that may impede work away from the machine. Failure to do so may result in injury.



- Long hair should be tied back. Failure to do so may result in injury.

● Do not disassemble or repair

WARNING



- Do not attempt to disassemble or repair this machine. Otherwise there is a risk of failure, electric shock, or fire.

● Ultraviolet light (UV) and the UV-LED unit

WARNING



- Do not place combustibles under the UV-LED unit, and do not cover it with paper or cloth. There is a risk of fire or burns.
- Small amounts of ultraviolet light may leak from the UV-LED unit. To protect your eyes and skin from UV rays, please wear UV safety glasses, a face shield, a mask, gloves, and long-sleeved clothing.
 - (1) Exposure to ultraviolet light may result in skin inflammation. Even if no inflammation occurs, extended or repeated exposure may lead to chronic problems.
 - Acute problems: Inflammation
 - Chronic problems: Skin cancer, wrinkles, blotches
 - (2) Looking directly at the lamp while the lamp is on may result in eye pain or damage to eyesight. Even if no eye pain occurs, extended or repeated exposure may lead to chronic problems.
 - Acute problems: Ultraviolet keratitis, conjunctivitis, discomfort, pain, watery eyes
 - Chronic problems: Pterygium, cataracts



- Always wear the provided UV safety glasses. Otherwise there is a risk of eye pain or visual impairment.



- Always wear gloves and long-sleeved clothing. There is a risk of skin inflammation or skin damage due to ultraviolet (UV) radiation.

CAUTION



- The UV-LED unit becomes extremely hot. Be careful not to touch the LED after it has been turned off until it has sufficiently cooled.



- Do not expose the skin or eyes directly or indirectly to light from the UV-LED unit. The UV-LED unit emits ultraviolet (UV) light. Skin or eye exposure may result in inflammation.

NOTICE



- Avoid scratching or subjecting the UV-LED unit to excessive force. Disregarding this precaution may result in deformation or failure of the unit.
- Avoid touching the glass on the underside of the UV-LED unit with bare hands. Disregarding this precaution may impair UV ink curing. If the glass becomes dirty, wipe clean using a soft, clean cloth soaked with ethanol. Be careful to keep ethanol from splashing on the covers or other parts while cleaning. Disregarding this precaution may result in deformation or failure of the unit.

● **Other usage precautions**

WARNING



- Keep children away from the machine.

NOTICE



- The underside of the media may be soiled depending on how the printed media has been stored (due to weight when laying printed media rolls horizontally, for example) and the media type. Perform a test beforehand to check that the media does not transfer ink to the underside of the adjacent media.

● **Disposing of the product**

CAUTION



- Please contact your local retailer or service agent.
- When disposing of the product yourself, contact an industrial waste disposal operator or dispose of the product in accordance with local laws and regulations.

Prohibited Dangerous Actions

The following actions are dangerous and must never be performed when the power is on.

- **Do not insert your hands into the printer when the carriage is operating, such as during printing.**



- Do not insert your hands or other parts of the body into the printer from under the front cover.

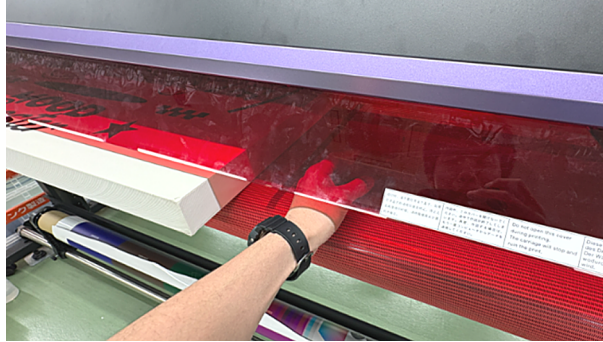

- Do not insert your hands or other parts of the body into the printer from the rear. Note that a large gap will be left open particularly when thick media is loaded. There is a risk of serious injury if hit by the carriage or head.

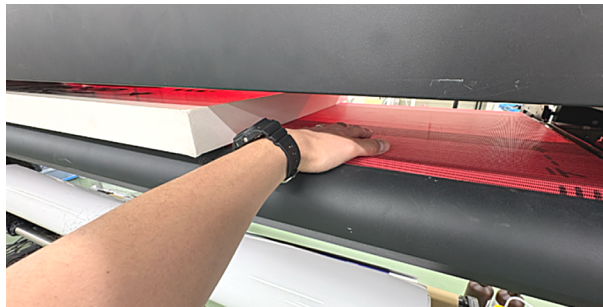

- **Keep hands and other parts of the body away from moving parts.**



- Ignoring this may result in machine failure or injury.
- Also take sufficient care to prevent objects from falling.

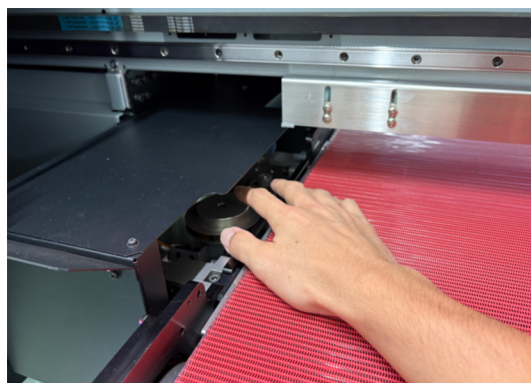

- **Do not insert your hands or other parts of the body under the media feeding belt, or place objects under it.**



- There is a danger of becoming trapped between the main unit frames when the media feeding belt rises or lowers.



- **Do not leave objects on top of the media feeding belt.**



- There is a risk of collision with the head if the carriage moves unexpectedly.

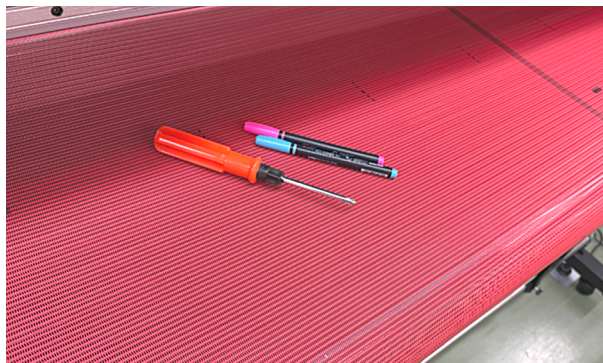

- **Do not look directly at the UV-LED.**



- Do not look directly at the UV-LED. Take particular care when working while sitting in a chair, as your head will be at the same height as the carriage.

- **Do not obstruct the movement of the carriage.**



- Do not touch the carriage while it is in operation (such as printing or cleaning).

Usage Restrictions

Usage Restrictions

⚠ WARNING



- The machine is extremely dangerous, as the carriage moves at high speed from side to side, and it contains high-temperature parts, parts with hazardous voltages, and UV-LEDs. The machine must only be used by persons who are fully aware of these hazards.

Operator Restrictions

⚠ WARNING



- The machine must only be operated by persons who have received Mimaki safety training or who have been trained by them.

Area Restrictions

⚠ WARNING



- Entry into the restricted area must be prohibited for anyone other than those who have received Mimaki risk assessment training or who have been trained by them. Trained personnel entering the restricted area must always wear UV safety glasses and protective gloves.

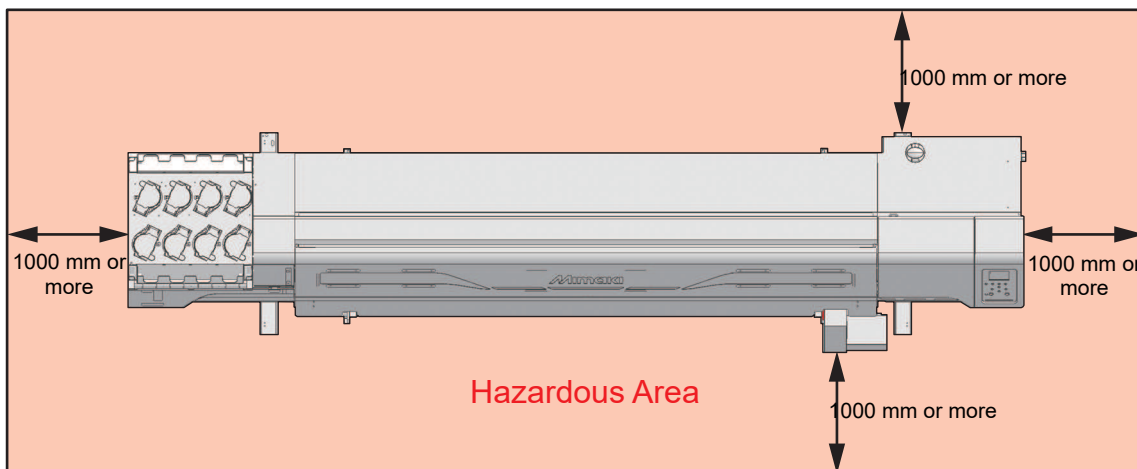

- Physically separate the machine, for example, by placing in a special room or in an area surrounded by a safety fence. It must be clear that this is a hazardous area.
 - Any special room provided should incorporate a door that can be locked or has a safety interlock
 - Any safety fences used must conform to the EN ISO 13857 standards.

● Information on ultraviolet light (UV) and handling the UV-LED unit inside the restricted area

⚠ WARNING



- Do not place combustibles under the UV-LED unit, and do not cover it with paper or cloth. There is a risk of fire or burns.
- Small amounts of ultraviolet light may leak from the UV-LED unit. To protect your eyes and skin from UV rays, please wear UV safety glasses, a face shield, a mask, gloves, and long-sleeved clothing.
 - (1) Exposure to ultraviolet light may result in skin inflammation. Even if no inflammation occurs, extended or repeated exposure may lead to chronic problems.
 - Acute problems: Inflammation
 - Chronic problems: Skin cancer, wrinkles, blotches
 - (2) Looking directly at the lamp while the lamp is on may result in eye pain or damage to eyesight. Even if no eye pain occurs, extended or repeated exposure may lead to chronic problems.
 - Acute problems: Ultraviolet keratitis, conjunctivitis, discomfort, pain, watery eyes
 - Chronic problems: Pterygium, cataracts



- Always wear the provided UV safety glasses. Otherwise there is a risk of eye pain or visual impairment.



- Always wear gloves and long-sleeved clothing. There is a risk of skin inflammation or skin damage due to ultraviolet (UV) radiation.

⚠ CAUTION



- The UV-LED unit becomes extremely hot. Be careful not to touch the LED after it has been turned off until it has sufficiently cooled.



- Do not expose the skin or eyes directly or indirectly to light from the UV-LED unit. The UV-LED unit emits ultraviolet (UV) light. Skin or eye exposure may result in inflammation.

NOTICE



- Avoid scratching or subjecting the UV-LED unit to excessive force. Disregarding this precaution may result in deformation or failure of the unit.
- Avoid touching the glass on the underside of the UV-LED unit with bare hands. Disregarding this precaution may impair UV ink curing. If the glass becomes dirty, wipe clean using a soft, clean cloth soaked with ethanol. Be careful to keep ethanol from splashing on the covers or other parts while cleaning. Disregarding this precaution may result in deformation or failure of the unit.

Connecting the Power



- Plug the power cable plug into a grounded power outlet. Otherwise there is a risk of failure, electric shock, or fire.
 - When installing electrical outlets, perform grounding work to prevent electric shock. All electrical work (Class C grounding work; formerly Type 3 grounding work) must be handled by a licensed electrician.
-



- Make sure the connections are correct. Incorrect connections may result in damage to the equipment.
 - Be careful to avoid problems in wiring configuration.
-

Notes on Handling Ink or any Other Liquid Used with the Machine

Precautions regarding ink, maintenance liquid, or other liquids used with this machine are included with the containers. Thoroughly read them and make sure you understand the contents.



- Be sure to read the safety data sheet (SDS) before use. <https://mimaki.com/supply/sds/>

CAUTION



- Pay close attention to ventilation and be sure to wear safety glasses, gloves, and a mask when handling ink, maintenance liquid, waste ink, or other solutions used with the machine. Leaking ink may adhere to the skin or get into the eyes or mouth.



- Do not subject cases containing ink to strong shock or violent shaking. Do not attempt to refill the ink. Leaking ink may adhere to the skin or get into your eyes or mouth.



- Do not disassemble cases containing ink. Leaking ink may adhere to the skin or get into your eyes or mouth.



- Do not store ink, maintenance liquid, or other liquids used with the machine in locations where children may enter.



- When disposing of ink, maintenance liquid or other liquid used with the product, or containers or non-woven fabric contaminated with ink or other liquid, contact an industrial waste disposal operator or dispose of the product in accordance with the local laws and regulations.

NOTICE



- Do not store ink, maintenance liquid, or other liquids used with the machine in locations exposed to direct sunlight.
- Do not store ink, maintenance liquid, or other liquids used with the machine in environments where cutting fluid or other volatile substances (such as amines or modified amine alcohol) are present in significant quantities. Storage in such places increases the risk of failure or ejection failures (e.g., nozzle clogging or deflection).
- Do not use ink, maintenance liquid, or other liquids used with this machine with other printers. Doing so may cause failure.



- Be sure to store them in a low place no higher than 1 m above the floor. Otherwise there is a risk of scattering if the containers fall.
- Store in tightly sealed containers.
- Store in a cool, dark place.
 - (1) Store ink in a place where ink does not freeze. Using defrosted ink may deteriorate ink constituents and reduce print quality.
 - (2) When ink is moved from a cold place to a warm place, leave it in the environment where the machine is installed for at least three hours before using it.
 - (3) Open the container just before installing it, and use it up as quickly as possible. If it is opened and left for an extended period of time, print quality may be reduced.



- Do not touch the metal parts of the ink IC chip. Static electricity may damage the ink IC chip, and dirt or damage may cause the ink IC chip read error.



- Printing is not possible when different types of ink IC chips are used.
- If the ink bottle mounted on the machine is dented, it may still be used.

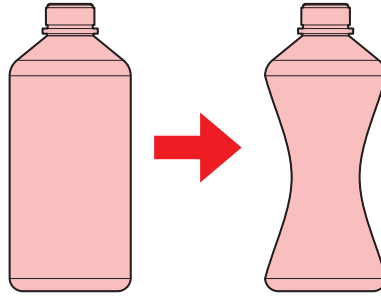

Ink Specifications

Item		UJ330H-160
Type		Special UV curing ink (Mimaki Engineering product)
Color		Cyan (C) Magenta (M) Yellow (Y) Black (K) Light cyan (Lc) Light magenta (Lm) White (W) Clear ink (Cl)
Form		Bottle
Ink capacity ^{*1}		1000 ml
Expiration date		As indicated on the ink bottle However, after opening, it should be consumed within three months, even if before the expiration date.
Storage temperature ^{*3}	When stored	5 to 30 °C (daily mean temperature) • However, not more than 1 month at 30 °C
	During transportation	1 to 60 °C • However, not more than 120 hours at 60 °C, and not more than 1 month at 40 °C • Where possible, avoid storing in cold locations below 0 °C and hot locations above 40 °C.

Restrictions Concerning the Expiration Date of Ink Used in the Machine

Example: When the expiration date is April 20xx

- May 20xx: Replace with new ink or use up as quickly as possible. Printing is possible.
- June 20xx: Replace with new ink or use up as quickly as possible. Printing is possible.
- July 20xx: Printing is not possible.



- The message appears on the display.



- The ink expiration date is indicated on the ink container. Expired ink may cause ejection failures or alter the color tone. Printing is possible even if the ink has passed its expiration date. Nevertheless, we recommend replacing with new ink or using up as quickly as possible.
-

Installation Precautions

⚠ WARNING



- Adhesive and releasing agents may contain flammable constituents such as thinner. This machine is not explosion proof. There is a risk of explosions.



- Do not install the machine in a place close to fire.
- Do not place flower vases, pots, cups, containers containing cosmetics, chemicals or water, or small metal items on or close to the machine. If they enter the machine, there is a risk of failure, electric shock, or fire.



- Do not install this machine in humid locations or locations where it may be exposed to splashing water. Otherwise there is a risk of failure, electric shock, or fire.



- Do not install the machine in a place where children may enter.



- When performing work that requires disabling safety functions (such as safety interlocks) during installation or maintenance, be sure to review and follow the warnings listed for each step in advance. Improper handling may result in serious injury.

⚠ CAUTION



- A ventilation system must be provided if the machine is installed in a poorly ventilated area or sealed room.
- Be sure to observe the following points regarding exhaust port installation:
 - (1) Exhaust port installation must conform to local environmental, health, and safety (EHS) guidelines.
 - (2) If the exhaust port is fitted with a shutoff valve, the valve must be open when the machine is in use.

NOTICE



- Do not install the machine in areas where there is dust or fine particles. If water gets inside the machine, it may cause failures or ejection failures (such as nozzle clogging or nozzle deflection).
- Do not place the machine in a location where it is exposed to air from an air conditioner or other source. Dust and other particles may enter the interior of the machine.
- Do not install the machine in an unstable location or in an area subject to vibration. This can cause failures or ejection failures (such as nozzle clogging or nozzle deflection).
- Do not place the machine in direct sunlight.
- Do not install the machine in locations subject to extreme temperature fluctuations. This can cause failures or ejection failures (such as nozzle clogging or nozzle deflection).
- Do not install the machine in a location where large machinery that generates noise is located.
- Do not install the machine in areas where vapors from photographic fixing agents or acidic gases (such as acetic acid or hydrochloric acid) are present, or where the air is filled with metalworking fluids or highly volatile substances (such as amines or amine-modified alcohols). If installed in such an environment, the ink on the print head surface will harden, causing failures or ejection failures (such as nozzle clogging or nozzle deflection).



- Operating environment: 20 to 30 °C (68 to 86 °F), 35 to 65 %RH (no condensation)
- Temperature range in which accuracy is guaranteed: 20 to 25 °C (68 to 77 °F)

Installation Space

Provide the following space around the machine to allow safe and proper replacement of ink and media:

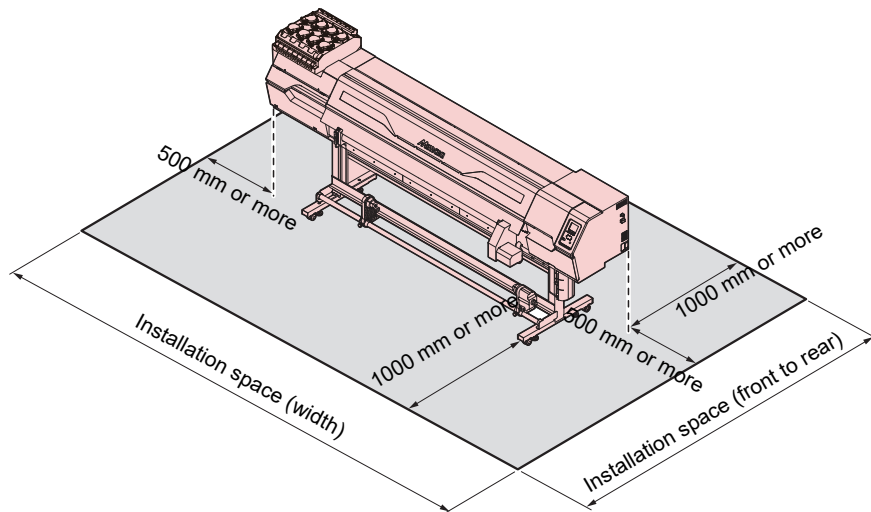

Item	UJ330H-160
Width ^{*1}	At least 4,225 mm (3,225 mm)
Depth ^{*1}	At least 2,785 mm (785 mm)
Height ^{*1,*2}	(1,420 mm)
Weight	386 kg

*1. The figures in parentheses indicate machine dimensions.

*2. Excluding the Ink bottle height

When relocating the machine

Contact your local dealer or our service office. There is a risk of failure or damage to the machine if you try to move it yourself.

Safety Interlocks

The machine is equipped with interlocks to ensure safety during use.

Printing will abort if you open the covers while printing is underway. The RIP data will need to be resent.

- Safety interlock locations

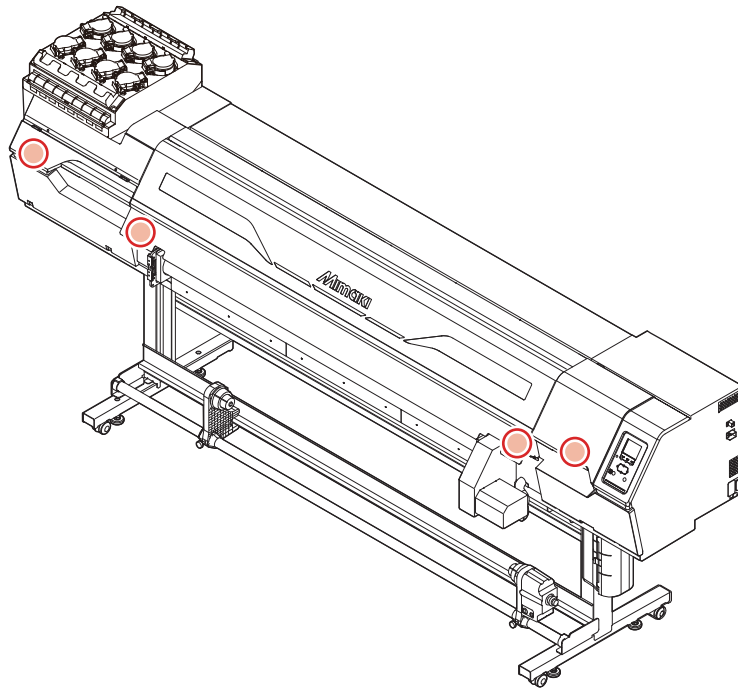







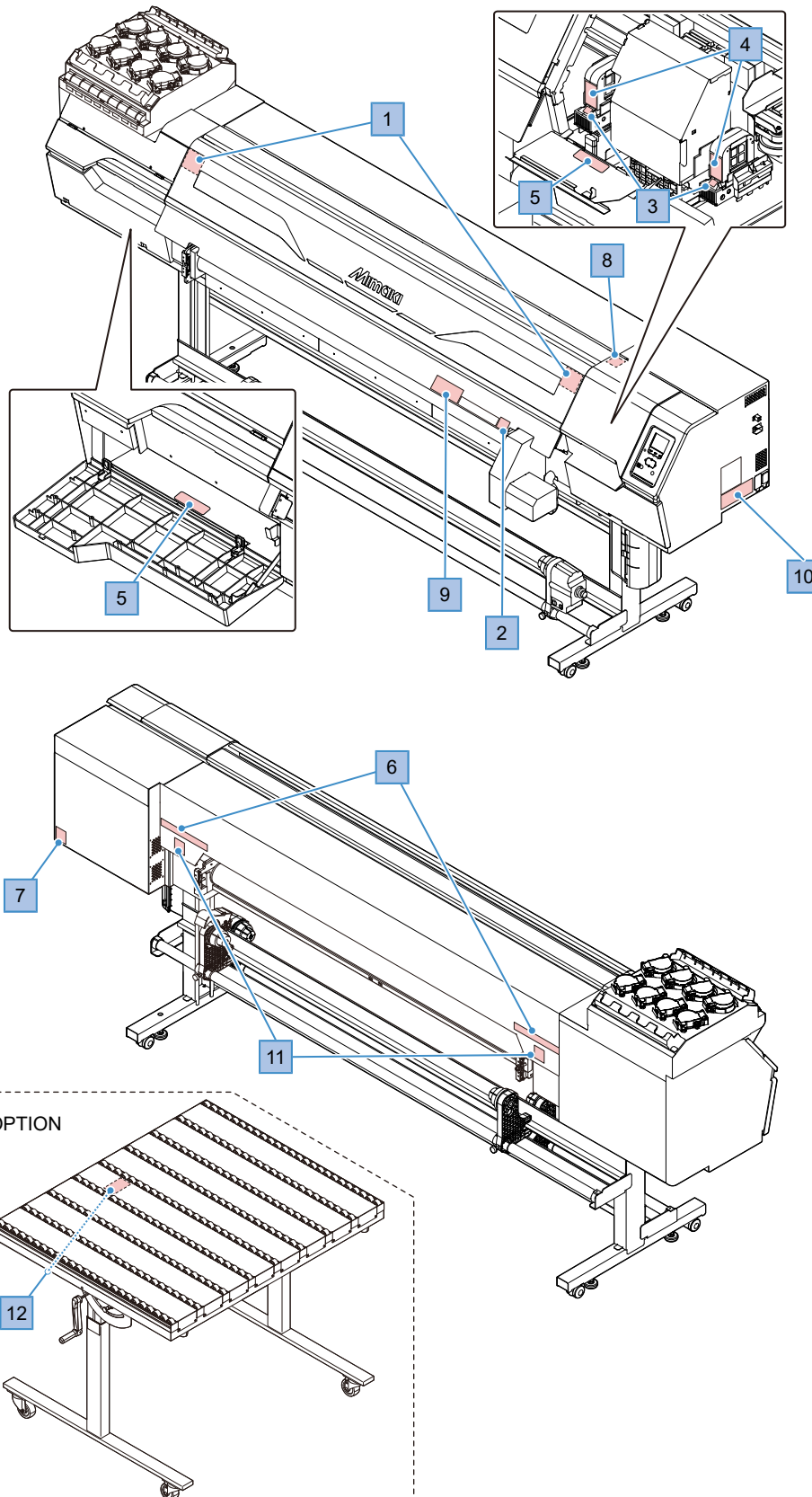



Warning Label

Make sure you fully understand the details indicated on the various warning labels.

If any of the warning labels becomes dirty and illegible or peel off, contact your local dealer or our service office to request new warning labels.

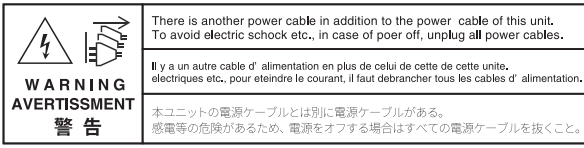

No.	Order code	Label	Details
1	M910931	 <p>CAUTION ATTENTION</p> <p>COVER HAZARD May result in severe injury. When open and close the cover, hold a cover until the end.</p> <p>COUVERCLE-DANGER Peut entraîner de graves blessures. Lors de l'ouverture ou de la fermeture du couvercle, tenir le couvercle jusqu'à la fin.</p> <p>カバー急落下あり 指を挟まれると、ケガや骨折の恐れあり。 カバーの開閉は、最後まで手を添えて行ってください。</p> <p>M910931</p>	Beware of opening and closing parts. Injury may result if hands become trapped.
2	M907833		Indicates dangerous moving parts.
3	M903239		Indicates hot parts.
4	M913419	 <p>WARNING AVERTISSEMENT 警告</p> <p>ULTRAVIOLET RADIATION RAYONS ULTRAVIOLETS 紫外線放射 紫外線照射</p> <p>Ultraviolet Radiation, When exposed to ultraviolet light, there is a risk of blindness or burns. Rayonnement Ultraviolet. Exposition dangereuse pour l'œil et la peau. Peut provoquer la cécité et des brûlures.</p> <p>紫外線が照射されています。 紫外線を浴びると失明や火傷の恐れがあります。 紫外線照射注意 紫外線照射を長時間受ると失明や火傷の恐れがあります。</p>	Beware of ultraviolet light.
5	M903330		Wear safety glasses and gloves while working.
6	M905811	 <p>警告 警告 WARNING WAARSCHUWING AVERTISSEMENT</p> <p>手指和身体請勿靠近运转部位，以免造成危險 危険な移動部 指や体を近づかないように HAZARDOUS MOVING PARTS Keep fingers and other body parts away. GEFÄHRLICHE BEWEGLICHE TEILE Finger und andere Körperteile fernhalten. PIECES MOBILES DANGEREUSES Doigts et autres parties du corps sont hors de portée.</p>	Indicates dangerous moving parts.
7	M907935		Indicates dangerous live parts.
8	M917991		Indicates illuminating LED hot parts.
9	M917420	 <p>RISK GROUP 3</p> <ul style="list-style-type: none"> • WARNING UV emitted from this product. • Avoid eye and skin exposure to unshielded product. <p>GROUPE DE RISQUE 3</p> <ul style="list-style-type: none"> • AVERTISSEMENT : UV emis par ce produit. • Eviter l'exposition des yeux et de la peau a un produit non blindé. <p>UV</p>	Beware of UV light.
10	M916035	 <p>WARNING AVERTISSEMENT 警告</p> <p>There is another power cable in addition to the power cable of this unit. To avoid electric shock etc., in case of power off, unplug all power cables.</p> <p>Il y a un autre câble d'alimentation en plus de celui de cette unité. Électriques etc., pour éteindre le courant, il faut débrancher tous les câbles d'alimentation.</p> <p>本ユニットの電源ケーブルとは別に電源ケーブルがある。 感電等の危険があるため、電源をオフする場合はすべての電源ケーブルを抜くこと。</p>	Describes the power cable.

No.	Order code	Label	Details
11	M910931	 <p>WARNING Ultraviolet is radiated. If you touch UV, you may lose your sight and get burnt.</p> <p>PREVENIR Les ultraviolets sont irradiés. Par les ultraviolets, vous pouvez perdre votre et pouvez me brûler.</p> <p>WARNING 紫外線が照射されています。 紫外線を浴びると、失明や火傷の恐れがあります。</p>	Beware of ultraviolet light.
12	M920701	 <p>警告 WARNING 挟まれ注意 BEWARE NOT TO BE CAUGHT</p> <p>警告 WARNING 落下注意 Do Not Drop</p>	<p>Note: Optional Roller Table Assy only Take care when folding them up. There is a risk of injury if the panel drops down or if your hands become trapped.</p>

Chapter 1 Before Use



This chapter

This chapter describes information essential before use, such as part names.

Part Names and Functions	30	Connecting a PC to the Product	44
Front	30	Using a LAN Cable	44
Rear and Right Side View	32	Using a USB Cable	45
Positioning Bar and Rear Clamp Roller	33	System Configuration	46
Ink Supply Unit	34	Installing the Mimaki Driver	47
Carriage	35	Installing RIP Software	47
Station	35	Obtaining Color Profiles	47
Print Area (Platen)	35	Setting Up RIP Software	47
Media Sensor	36	Ink Replacement Method	49
Power Supply Switch	37	When Ink Near End is Displayed	49
Operating Panel	38	When Ink End is Displayed	49
Connecting the Power Cable	41	Replacing Ink	50
Turning On the Power	41		
Turning Off the Power	42		

1.1 Part Names and Functions

Front

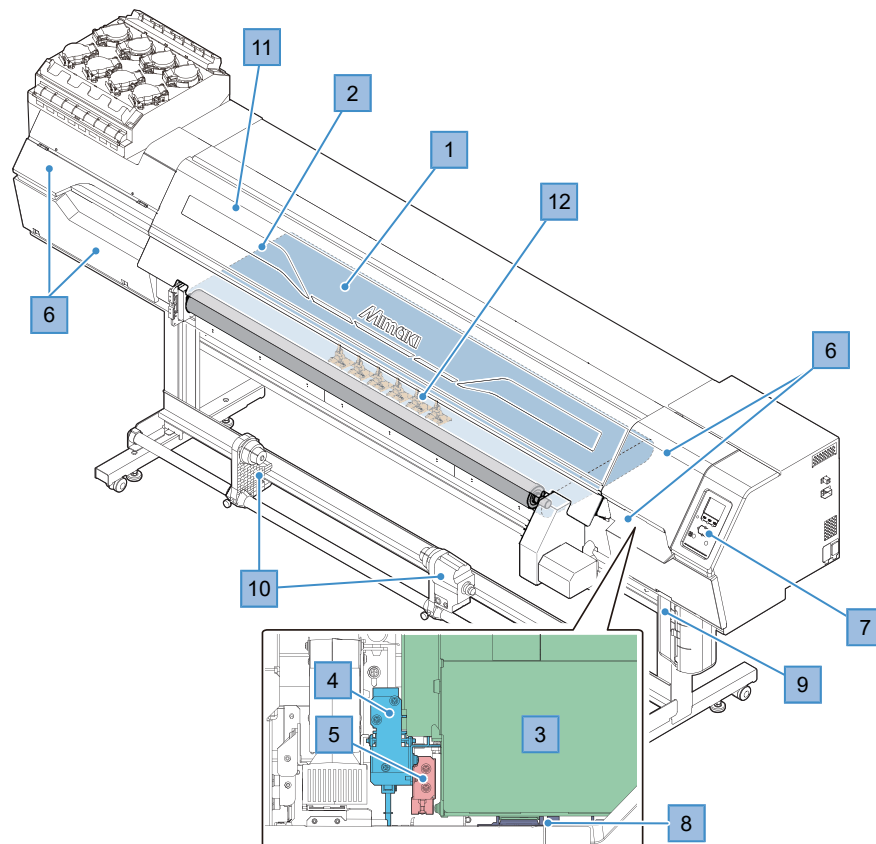

No.	Name	Overview
1	Print area (platen)	Print area. "Print Area (Platen)"(P. 35)
2	Media feeding belt	The mesh belt for feeding the media. The media is gripped to the belt using suction from the fan inside the mesh belt.
3	Carriage	Consists of components such as the print head and jam sensor. "Carriage"(P. 35)
4	Media thickness length measuring unit	Used to measure the media thickness.
5	DAS (automatic correction function) sensor	Sensor used for dot position correction and media width detection. Also used for detecting the presence of media during printing when media detection is set to "AUTO" and the media type is set to "Rigid".
6	Maintenance cover	Open the cover to perform maintenance on locations such as the carriage underside. Printing and automatic maintenance are not possible while the covers are open.
7	Operating Panel	Includes operating keys and displays indicating various settings and other items. "Operating Panel"(P. 38)
8	Station	Includes caps for protecting the print head, wipers, and an NCU for monitoring print head nozzle conditions. "Station"(P. 35)
9	Waste Ink Tank	Contains the container for waste ink. "Waste Ink Tank Replacement"(P. 150)
10	Take-up unit	Rolls up the printed roll media. "Take-up unit"(P. 64)

No.	Name	Overview
11	Front cover	Open the cover to load media or replace consumables. Printing and automatic maintenance are not possible while the covers are open.
12	Power lock roller	A roller positioned immediately after printing and used to suppress warping at the rear edge of the media. It is particularly effective for media with excessive warping.

Rear and Right Side View

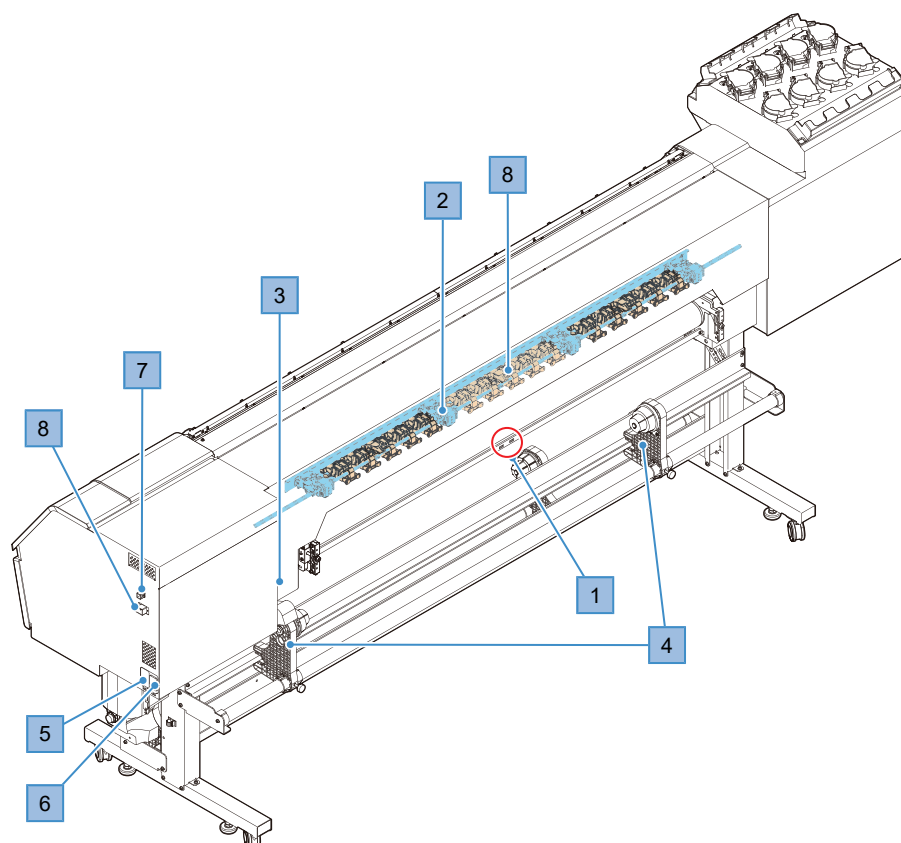

No.	Name	Overview
1	Media Sensor	Detects whether roll media is present. "Media Sensor"(P. 36)
2	Positioning bar ^{*1}	When rigid media is set, the front edge is aligned by placing the media against this bar.
3	Rear switch	Switch for turning the positioning bar raise/lower and media vacuum functions on and off. It can be used only in specific circumstances.
4	Feeding unit	Compatible with 2- and 3-inch paper cores. Allows one roll media to be loaded. "Loading the Roll Media"(P. 68)
5	AC inlet	Inlet for the power supply to the machine. Use the power cable provided. "Connecting the Power Cable"(P. 41)
6	Main power switch	The main power supply for the machine. To prevent ejection failures attributable to the print head (e.g., nozzle clogging or deflection), do not turn off the main power supply. "Power Supply Switch"(P. 37) "Turning On the Power"(P. 41) "Turning Off the Power"(P. 42)
7	LAN port	Connects to PC via a LAN cable. "Using a LAN Cable"(P. 44)
8	USB port	Connects to PC via a USB interface cable. "Using a USB Cable"(P. 45)
9	Rear clamp roller ^{*1}	A roller positioned immediately before printing to press down on rigid media from above. Prevents the media from coming into contact with the underside of the carriage due to warping.

1. The rear clamp roller operates in conjunction with the positioning bar. ["Positioning Bar and Rear Clamp Roller"\(P. 33\)](#)

Positioning Bar and Rear Clamp Roller



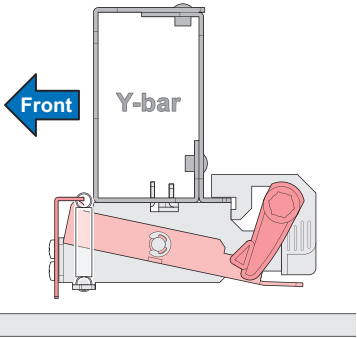
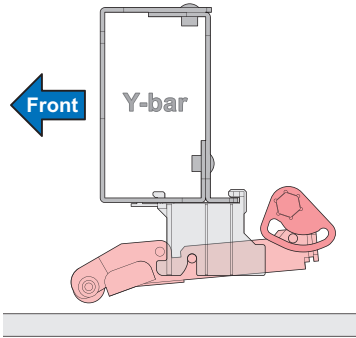
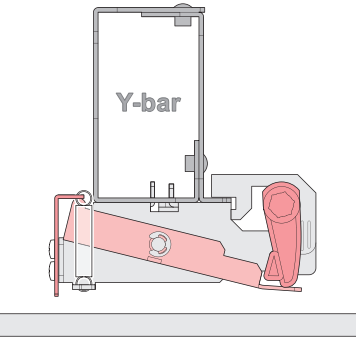
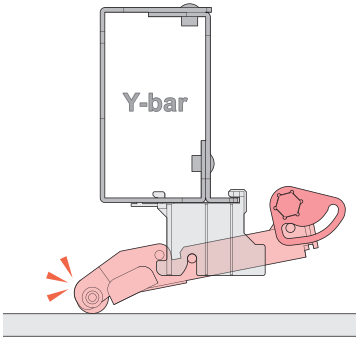
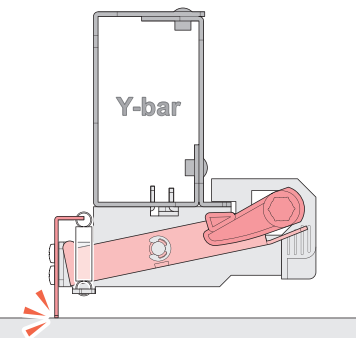
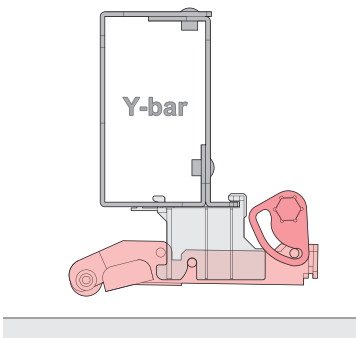

● Overview

The positioning bar and rear clamp roller operate in conjunction as shown in the following table.

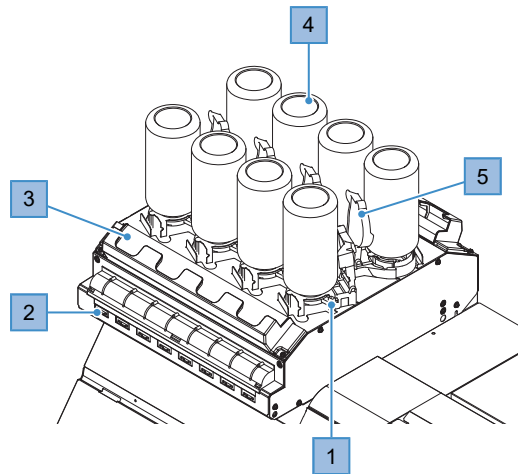
Schematic for each operation		Function description
Positioning bar	Rear clamp roller	
<p>Positioning bar central position</p> 	<p>Rear clamp roller central position</p> 	<p>Positioning bar and rear clamp roller both in central position</p> <ul style="list-style-type: none"> Positioning bar and rear clamp roller both not in contact with media <p>[When using roll media] Both the positioning bar and the rear clamp roller are in the central position when the media type is set to roll media.</p> <p>[When using rigid media] Operation when the media type is set to rigid media and [Rear clamp roller] is disabled in the media settings.</p>
<p>Positioning bar off</p> 	<p>Rear clamp roller on</p> 	<p>Positioning bar raised</p> <ul style="list-style-type: none"> Media held by rear clamp roller <p>[Only when using rigid media] Operation when the media type is set to rigid media and [Rear clamp roller] is enabled in the media settings.</p> <ul style="list-style-type: none"> Used to minimize media warping and to improve feeding accuracy.
<p>Positioning bar on</p> 	<p>Rear clamp roller off</p> 	<p>Rear clamp roller raised</p> <ul style="list-style-type: none"> Positioning bar lowered <p>[Only when using rigid media] Operation that allows to butt the media edge against it when setting the media.</p>

Ink Supply Unit



No.	Name	Overview
1	Ink lever	Slide the lever to the right to remove the ink bottles.  P. 50
2	Ink IC chip slot	For inserting the ink IC chips provided with the ink.  P. 54
3	Ink wipe pad	Pad for soaking up ink droplets from the ink bottle special caps.  P. 50
4	Ink bottle	Mount the ink bottles.  P. 54
5	Light-blocking cover	Cover to prevent light entering the ink supply unit when the ink bottles are removed.

Carriage

The carriage includes a print head for ejecting ink, and a jam sensor for stopping the carriage when media clogs. Printing occurs as ink is ejected while traversing left and right.

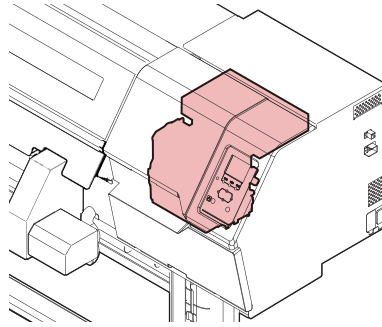

Station

The station includes caps for keeping the print head nozzle surface from drying out, a wiper required for print head maintenance, and an NCU for monitoring print head nozzle conditions.

The NCU (Nozzle Check Unit) automatically checks whether the nozzle is clogged. Setting various functions enables automatic print head cleaning or printing using other nozzles. ["Registering Nozzle Recovery"\(P. 114\)](#)

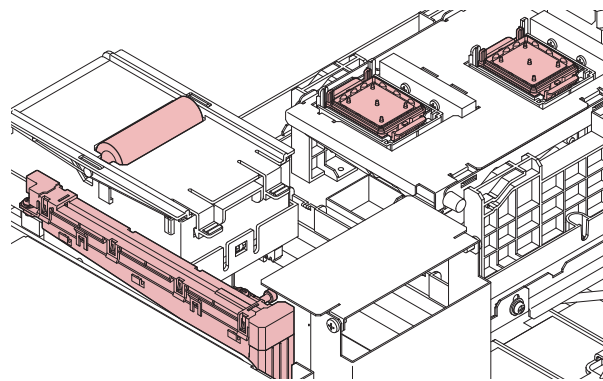

Print Area (Platen)

Print area. The media is held by vacuum from the fan inside the mesh belt in the area where the carriage scans to prevent it from lifting up.

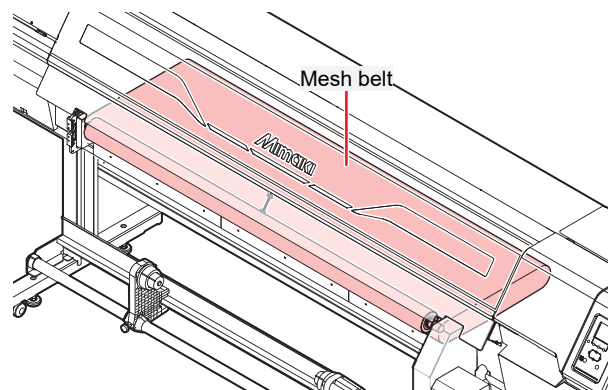

Media Sensor

The two media sensors detect the presence/absence of media. The sensor must be covered by the media to detect the media width.

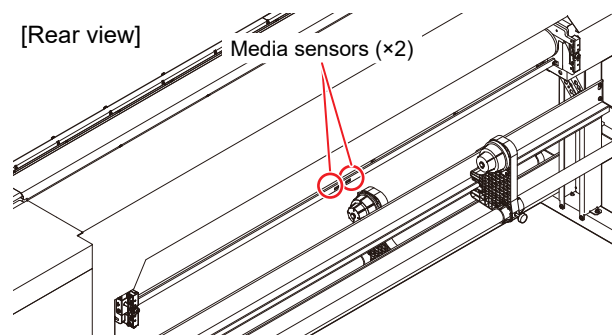
**Important!**

- This media sensor is used for roll media only. It is not used when "Rigid" or "Clear Rigid" is selected for the media type.
- If the media becomes slack on the feed side, such as when it is fed backward, the media may not be detected correctly due to the distance from the sensor. Because of this phenomenon, the printer internally manages media slack on the feed side, and media detection is not performed if it is determined that slack exists. Media detection is automatically resumed once the media has been fed by the distance necessary to eliminate the slack.
- If the media is removed using manual backward feeding, the media sensor may not respond accurately.

Power Supply Switch

● Main power switch

This is located at the rear on the right-hand side of the product.

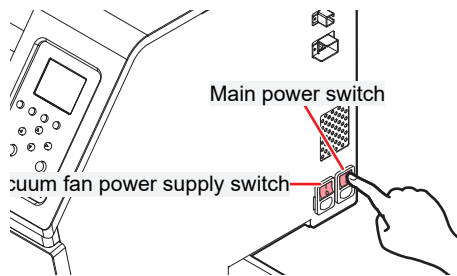

- Do not turn off the main power supply. Turning off the main power supply will disable the automatic maintenance function (including nozzle clogging prevention function and ink discharge channel cleaning function). This increases the risk of ejection failures (such as nozzle clogging or deflection).

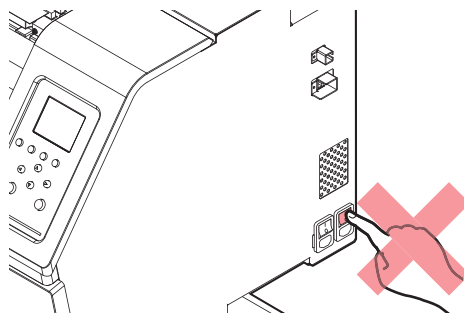

● [END/POWER] key

The [END/POWER] key is the key normally used to turn the power on and off.

To turn off the power, hold down the [END/POWER] key. Press the [ENTER] key once the instructions appear on the display.

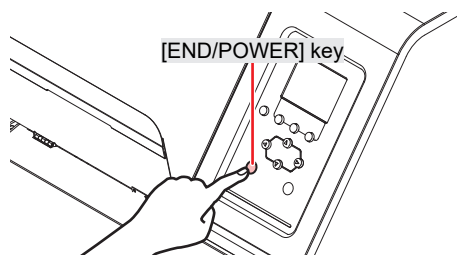

Operating Panel

This is used to control the product and make/change settings.

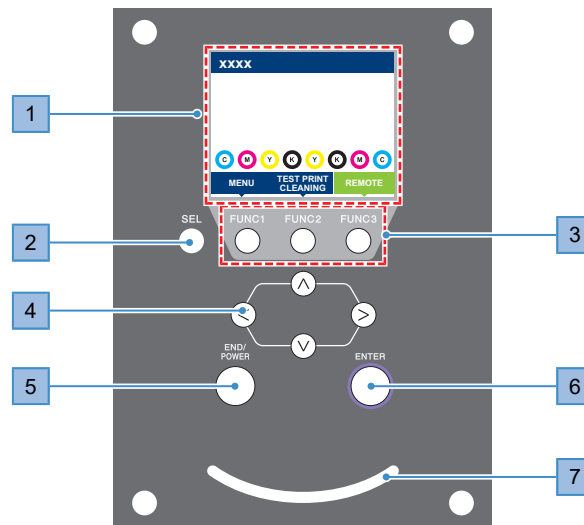

No.	Name	Overview																						
1	Display	Display																						
2	[SEL] key	Selects the function for the corresponding [FUNCTION] key.																						
3	[FUNCTION] key	Used for test printing, head cleaning, and editing settings [FUNCTION] key																						
4	[JOG] key ▲▼◀▶	Used to move the carriage, feed media, and select settings																						
5	[END/POWER] key	Used to cancel the last setting entered, return to the previous level of the setting menu, or to turn power on and off <ul style="list-style-type: none"> • Illuminates in blue when the power is on. Turning On the Power • To turn off the power, hold down the key. Turning Off the Power 																						
6	[ENTER] key	Used to move to the next level menu and to confirm settings. This can also be used to display product information. Displaying Machine Information (Local Guidance)																						
7	Status lamp	This lamp indicates the machine status. <table border="1"> <tbody> <tr> <td>Off</td> <td>Illuminated</td> <td>Indicates LOCAL mode. Used for test printing, maintenance, and settings</td> </tr> <tr> <td rowspan="2">Light blue</td> <td>Illuminated</td> <td>Indicates REMOTE mode. The product is in standby to receive print data.</td> </tr> <tr> <td>Flashing</td> <td>Indicates that printing is in progress. This also flashes to indicate test printing—for example, when printing built-in patterns.</td> </tr> <tr> <td>Blue</td> <td>Illuminated</td> <td>Indicates that data remains to be printed. Switch to REMOTE mode and start printing</td> </tr> <tr> <td>Green</td> <td>Flashing</td> <td>Indicates that automatic maintenance is underway. Some functions will be limited until maintenance has ended.</td> </tr> <tr> <td>Yellow</td> <td>Flashing</td> <td>Ink Near End status (very little ink remains). When Ink Near End is Displayed</td> </tr> <tr> <td rowspan="2">Red</td> <td>Flashing</td> <td>An error has occurred. Refer to the error code list and take appropriate action. Error Message</td> </tr> <tr> <td>Illuminated</td> <td>A system error (SYSTEM HALT) has occurred. Contact our service office. SYSTEM HALT</td> </tr> </tbody> </table>	Off	Illuminated	Indicates LOCAL mode. Used for test printing, maintenance, and settings	Light blue	Illuminated	Indicates REMOTE mode. The product is in standby to receive print data.	Flashing	Indicates that printing is in progress. This also flashes to indicate test printing—for example, when printing built-in patterns.	Blue	Illuminated	Indicates that data remains to be printed. Switch to REMOTE mode and start printing	Green	Flashing	Indicates that automatic maintenance is underway. Some functions will be limited until maintenance has ended.	Yellow	Flashing	Ink Near End status (very little ink remains). When Ink Near End is Displayed	Red	Flashing	An error has occurred. Refer to the error code list and take appropriate action. Error Message	Illuminated	A system error (SYSTEM HALT) has occurred. Contact our service office. SYSTEM HALT
Off	Illuminated	Indicates LOCAL mode. Used for test printing, maintenance, and settings																						
Light blue	Illuminated	Indicates REMOTE mode. The product is in standby to receive print data.																						
	Flashing	Indicates that printing is in progress. This also flashes to indicate test printing—for example, when printing built-in patterns.																						
Blue	Illuminated	Indicates that data remains to be printed. Switch to REMOTE mode and start printing																						
Green	Flashing	Indicates that automatic maintenance is underway. Some functions will be limited until maintenance has ended.																						
Yellow	Flashing	Ink Near End status (very little ink remains). When Ink Near End is Displayed																						
Red	Flashing	An error has occurred. Refer to the error code list and take appropriate action. Error Message																						
	Illuminated	A system error (SYSTEM HALT) has occurred. Contact our service office. SYSTEM HALT																						

Display

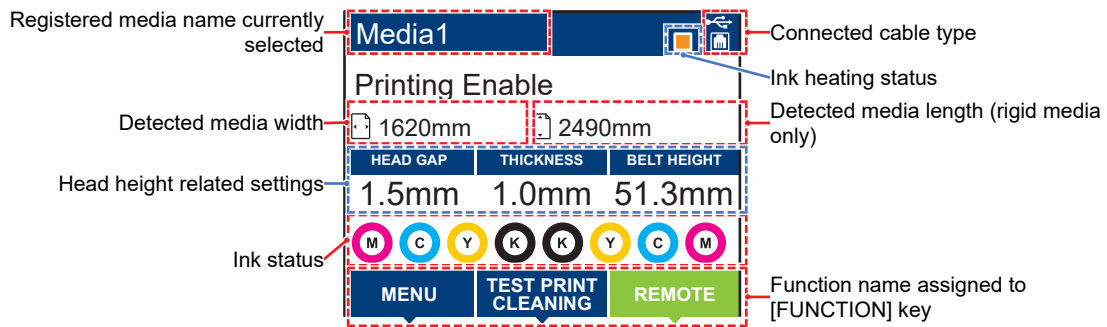

● Ink heating status

The ink heating status and errors are indicated by different colors.

- Orange: Adjusting to temperature setting. Ink heating starts automatically before printing.
- Light blue: Temperature being maintained stable after reaching temperature setting.
- Green: Ink temperature is stable. Printing can be started immediately.
- Gray: Ink heating is turned off.
- Red: An ink heating related error has occurred.

MENU mode

Four menu modes are available.

Name	Overview
LOCAL mode	Used for test printing, maintenance, and settings
REMOTE mode	Prints the print data received from a PC.
MENU mode	Press the [MENU] on the LOCAL mode screen to switch to MENU mode. This is used to set various functions.
NOT-READY mode	Status before media is detected









Ink status

Ink bottle status such as remaining ink levels and ink errors are indicated by icons.

Icon	Overview
	Displays remaining ink levels using a 9-stage icon.
	Full
	1/8 used
	1/4 used
	3/8 used
	1/2 used
	5/8 used
	3/4 used
	7/8 used
	Very little ink remains. Prepare fresh ink.
	Printing is not possible. Displayed when ink is depleted or an ink error has occurred. Ink Error

[FUNCTION] key

This section describes the functions and roles assigned to the [FUNCTION] key.

Icon	Overview
	Displays the various menu screens.  "Setup"(P. 107)
	Displays maintenance functions such as test printing and cleaning.
	Switches from LOCAL mode to REMOTE mode.
	Displays adjustment functions such as feed adjustment and drop position adjustment.
	Turns the interior light on and off.
	Clears received data.
	Used to switch from REMOTE mode to LOCAL mode
	Used to move to the previous menu screen
	Used to move to the next menu screen
	Used to close the confirmation screen in response to prompts or other messages
	Used to disable functions
	Indicates that the function is assigned. Displays settings and functions.
	Used to enable or disable multiple items
	Turns the vacuum fan on and off.
	Cancels the media set state.
	Displays the register mark detection screen for pullback printing.

Displaying Machine Information (Local Guidance)

Press the [ENTER] key on the LOCAL mode screen to display the following information.

- Ink information: Displays ink type, remaining ink levels, and ink errors.
- Information: Displays information such as media width, media length (rigid media only), product serial number, firmware version, command version, and LAN connection status.
- Nozzle check: Displays the number of nozzles detected as clogged in the nozzle check.

1.2 Connecting the Power Cable

- 1** Check to confirm that the main power supply is turned off.
- 2** Connect the cable band to the machine.
- 3** Connect the power cable to the inlet of the machine.
- 4** Secure the power cable to the cable band.
 - Pass the power cable through the clamp and clamp until it clicks into place.

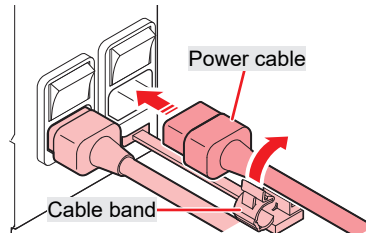

- 5** Plug the power plug into the power outlet.

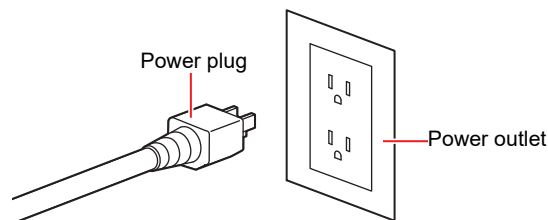

- Do not handle the power plug with wet hands. Disregarding this precaution may result in electric shock.

Turning On the Power

- 1** Check to confirm that the main power supply is turned on.
 - If the main power supply switch is not turned on, set to "I".

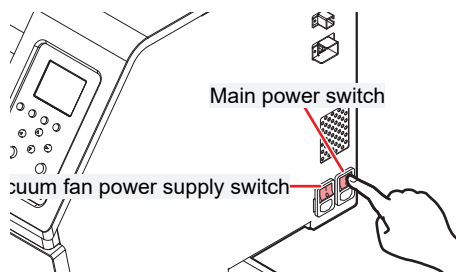

2 Press the [END/POWER] key to turn on power.

- The firmware version appears on the display, and the initial operation is executed. The machine will then enter the Media Select mode, and is ready for use.

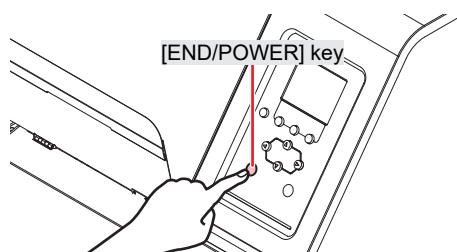

- If sudden temperature fluctuations (of ± 8 °C or more) are detected while the power is turned off, maintenance will be performed automatically when the machine is restarted. If a warning message appears when the machine is restarted, perform a test print to check the nozzle state.

3 Turn on the power for the connected PC.



- Close the front cover and maintenance covers. Leaving any of the covers open will disable the automatic maintenance function (including nozzle clogging prevention function and waste ink draining channel cleaning function). This will increase the risk of failure or ejection failures (e.g., nozzle clogging or deflection).

Turning Off the Power



- Check the following when turning off power:
 - (1) The front cover and maintenance covers are closed.
 - Leaving any of the covers open will disable the automatic maintenance function (including nozzle clogging prevention function and waste ink draining channel cleaning function).
 - (2) The carriage has returned to the capping station.
 - If not, the print head nozzle may dry out, resulting in ejection failures (such as nozzle clogging or deflection).
 - (3) Data is not being received
 - (4) No errors have occurred.
 - Problems Causing Messages to Appear

1 Turn off the power to the PC connected.

2 Hold down the [END/ POWER] key.

- A power off confirmation screen appears. Press the [ENTER] key to turn the power off.

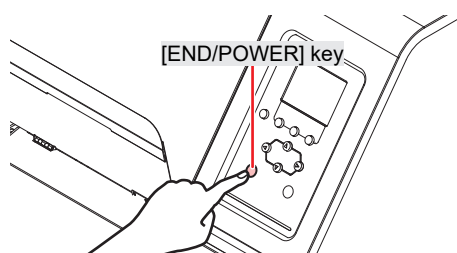



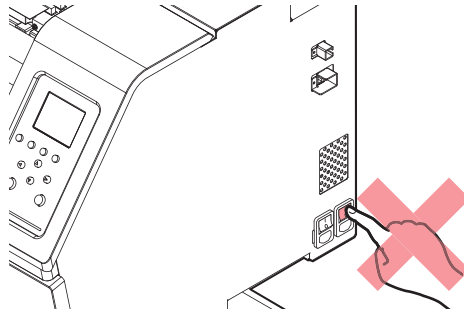

- Do not turn off the main power supply. Turning off the main power supply will disable the automatic maintenance function (including nozzle clogging prevention function and ink discharge channel cleaning function). This increases the risk of ejection failures (such as nozzle clogging or deflection).



1.3 Connecting a PC to the Product

Connect the machine to the RIP PC. The following cables can be used:

1.  "Using a LAN Cable"(P. 44) **(Recommended)**
2.  "Using a USB Cable"(P. 45)

Important! **When using the USB cable**

- Data may be transferred to the machine too slowly, **causing the carriage to pause at the left-hand or right-hand end** during printing.

Using a LAN Cable

Connect a PC to this product using a LAN cable. Insert a LAN cable until it engages with a click.



- Do not unplug the cable while data is being transferred.

● Network Connection Precautions

Make sure the network is set up as follows: Printing is not possible if the network is not set up correctly.

- Use a Category 6 or 6A LAN cable.
- The PC used to transfer print data must be located on the same network as this product. This product cannot be connected via a router.
- Use a 1000BASE-T compatible computer or switching hub. Printing requires 1000BASE-T support.

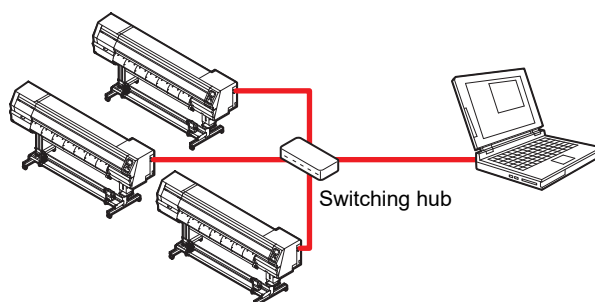

● Checking the LAN connection

1 Check the display on this product.

- Local guidance can be used for checking.  "Displaying Machine Information (Local Guidance)"(P. 40) Printing is not possible if "100Mbps", "10Mbps", or "No Connect" is displayed.

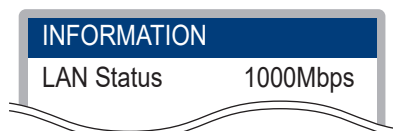

2 Check the lamp on the LAN connector.

- The LAN connector lamp illuminates when the machine is running.

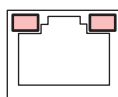

Color	Status	Overview
Green	Illuminated	Connected via 1000BASE-T
	Off	Connected via a network other than 1000BASE-T <ul style="list-style-type: none"> 1,000 Mbps is not supported if only the orange lamp is illuminated or flashing. Check the specifications for the PC, peripheral devices, and cable.
Orange	Illuminated	Linked up (connected).
	Flashing	Data being received
	Off	Link down (not connected)

Using a USB Cable

Connect a PC to this product using a USB interface cable.



- Do not unplug the cable while data is being transferred.



- If the PC does not have a USB port, contact your local distributor, our sales office, or service center.



When using the USB cable

- Data may be transferred to the machine too slowly, **causing the carriage to pause at the left-hand or right-hand end** during printing.

● USB Connection Precautions

- When connecting more than one UJ330H-160 to a PC
 - If the PC has more than one USB port, try connecting to a different USB port to check whether the product is correctly recognized. If the product is still unrecognized even when connected to a different USB port, use a commercially-available USB active repeater cable.
- When extending the USB cable
 - Use a commercially-available USB active repeater cable. However, make sure that the combined length of the USB cable and the USB active repeater cable does not exceed 20 m.
 - If the USB cable is extended, this may reduce the data transfer speed to the machine, causing the carriage to pause at the left-hand or right-hand end during printing.
- USB high-speed mode peripheral devices
 - It may not be possible to recognize USB peripheral devices if USB high-speed mode peripheral devices (e.g., USB memory, USB HDD devices) are connected to the PC to which the product is connected. If external USB hard disk drives or other similar devices are connected, this may reduce the data transfer speed to the machine, causing the carriage to pause at the left-hand or right-hand end during printing.
- Unplugging USB memory devices
 - When unplugging USB memory devices from the PC to which this product is connected, use "Stop" in "Safely removing hardware" before unplugging. Otherwise, an [ERROR 201 Command Error] will occur.

1.4 System Configuration

Use RIP software to request to print data created using applications like Illustrator or Photoshop.

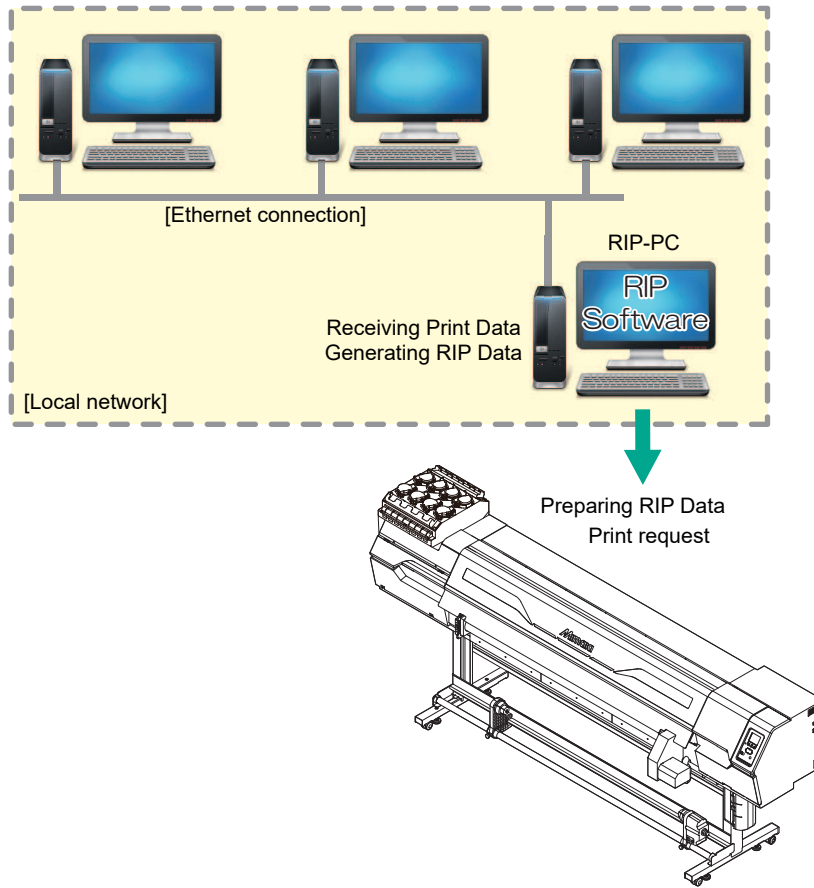

Installing the Mimaki Driver

1 Download the Mimaki driver from our website.

- <https://mimaki.com/download/inkjet.html>
[UJ330H-160] > [Driver/Utility]

2 Install the MIMAKI driver.

Installing RIP Software

The explanation here applies to MIMAKI RIP software (RasterLink).

1 Install RasterLink.

- The following icon appears on the PC desktop once the software has been installed.



- For more information, refer to the RasterLink installation guide. <https://mimaki.com/download/software.html>



- Once installed, activate the license for Rasterlink. Otherwise, "Profile Update" will not start.

Obtaining Color Profiles

Print quality (e.g., tone, bleeding) will vary depending on the media and ink set. To maintain consistent print quality, select a color profile that suits the media and ink set.

- The RasterLink Series includes a function allowing color profiles to be downloaded and installed directly from the Internet. For more information, refer to "Installing Profiles" in the RasterLink Series installation guide.
<https://mimaki.com/download/software.html>
[RasterLink Series used] > [Manuals]

Setting Up RIP Software

The explanation here applies to MIMAKI RIP software (RasterLink).

1 Launch RasterLink.

- The [Printer Management] screen appears.
- To add a new model, launch RasterLink, then select [Environment] > [Printer Management].

2 Register UJ330H-160.

(1) Click [Add].

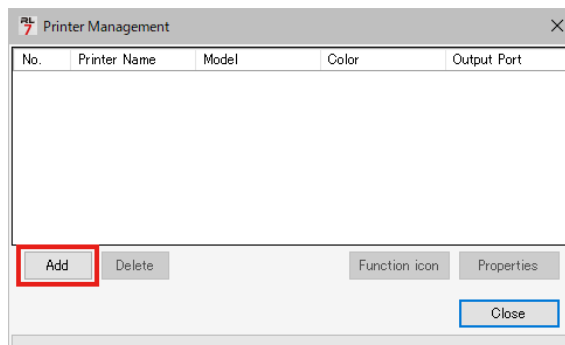

(2) Set the specifics for UJ330H-160.

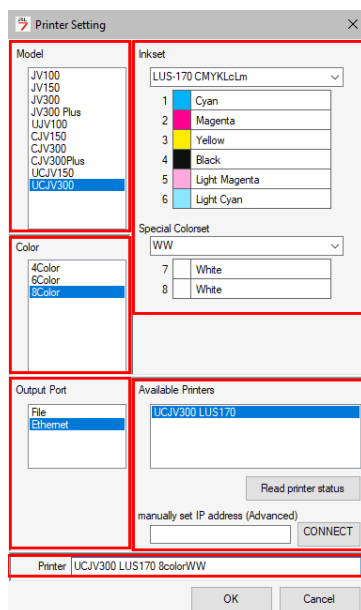

- Model: Select the model.
 - Color: Select the ink set filled.
 - Output Port: Select the cable connected.
 - Available Printers: Select UJ330H-160 connected.
 - Printer: Enter a name as required.
- (3) Click [OK].
- A confirmation screen appears.
- (4) Click [Yes].
- Printer registration starts.



- For more information, refer to the RasterLink installation guide. <https://mimaki.com/download/software.html>

1.5 Ink Replacement Method

When Ink Near End is Displayed

Ink levels are low. We recommend replacing with new ink as soon as possible, because the Ink bottle are nearly empty. Printing is still possible but continuous printing is not, and some maintenance functions such as cleaning are disabled. Note that ink may run out during printing.

To check which color ink needs to be replaced, press the [ENTER] key on the LOCAL mode screen.  ["Displaying Machine Information \(Local Guidance\)"\(P. 40\)](#)

When Ink End is Displayed

The ink has run out. Replace with new ink.

Thoroughly read the following and make sure you understand its contents.

 ["Notes on Handling Ink or any Other Liquid Used with the Machine"\(P. 18\)](#)



- Pay close attention to ventilation and be sure to wear safety glasses, gloves, and a mask when handling ink, maintenance liquid, waste ink, or other solutions used with the machine. Leaking ink may adhere to the skin or get into the eyes or mouth.

Replacing Ink

● Ink caps

The type of ink cap that can be used will differ depending on the ink type. Note that only the following combinations can be used.

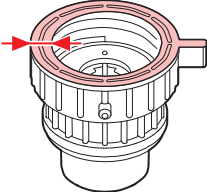
Ink type	Cap type
<ul style="list-style-type: none"> • ELS-170/175 ink • LUS-210 ink 	<p>[Cap B]</p> 

● Replacing Ink

- 1 Rotate the lever on the tank section from left to right.

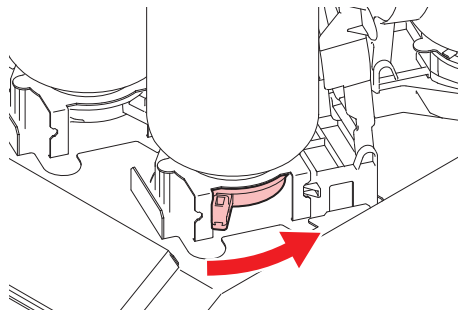

- Never attempt to rotate the ink bottles. Doing so may result in leaking ink.

- 2 Lift the ink bottles vertically.

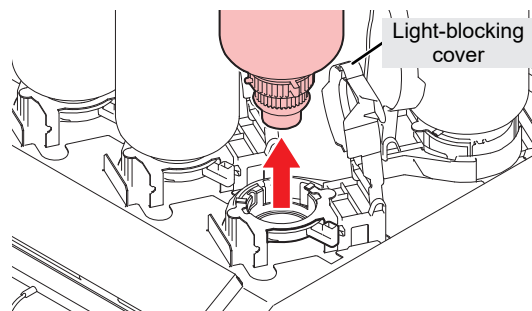

- Check to confirm that the light-blocking cover is closed when removing ink bottles. Close the light-blocking cover by hand if it is open. If the light-blocking cover is left open, the ink may harden, resulting in printer failure.
- Be careful to prevent ink leaks from the ink bottles.



- The O-rings fitted to the bottle caps may become detached when removing ink bottles. Refit the O-ring if it becomes detached.

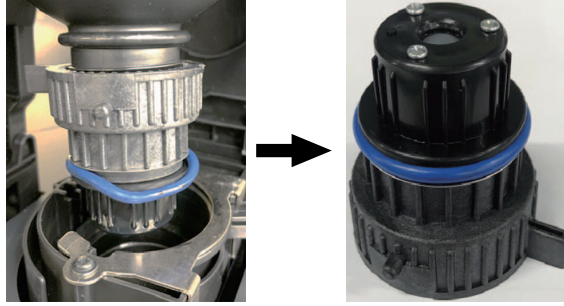

3 Soak up any ink droplets on the ink bottle caps.

- Use an ink wipe pad to absorb the ink sufficiently so that it does not drip.

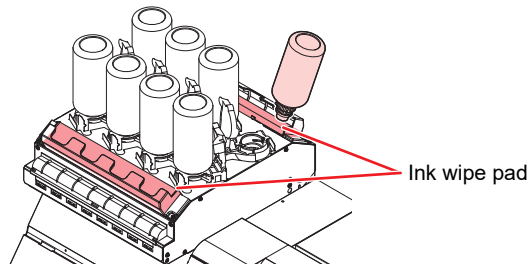

4 Wipe off any ink on the ink bottle caps with paper wipes.



- Check to confirm that there is no foreign matter, such as non-woven fabric scraps or dust, adhering to the ink bottle caps. Continuing to use it when it is dirty may result in foreign matter blocking the ink channels, causing ink leakage.

5 Remove the bottle caps from the ink bottles.

- If the ink bottle caps are tight, remove using a tightening tool.

6 Remove the ink IC chip.

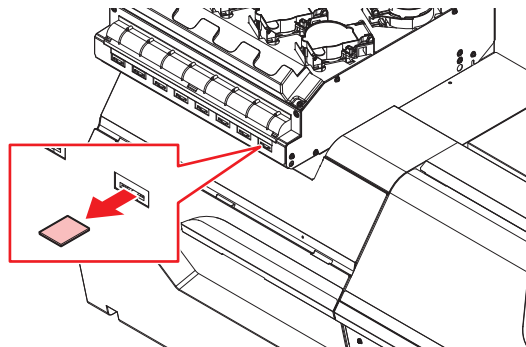

● Preparing the Ink

1 Shake the ink bottle to the left and right slowly at least 20 times.

- Tighten the ink bottle lid securely, then shake the bottle slowly from left to right to ensure that the ink moves inside, holding the ink bottle lid with a piece of recommended non-woven fabric.

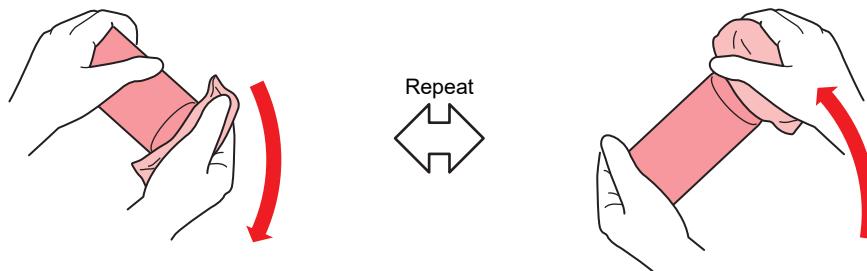

- Shake slowly. If the bottle is shaken too violently, ink may leak out or the air mixed in the ink may cause nozzle clogging.
- If the ink bottle is partially used, tilt it slowly until the ink bottle is upright.

2 Remove the ink bottle lid.

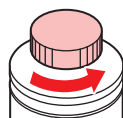

Important! If the mouth of the ink bottle is fitted with a seal

- Cut the seal open using a craft knife. There is a risk of ink leakage if parts of the seal remain.

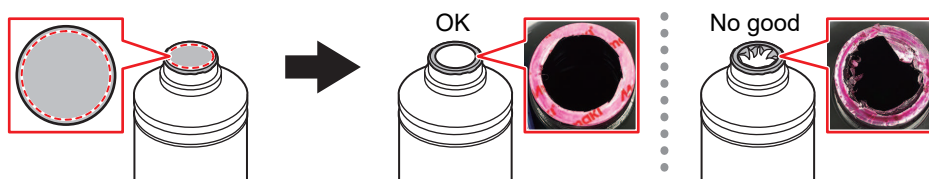

- Take care not to damage the mouth of the ink bottle. There is a risk of ink leakage if the mouth is damaged.
- Be careful not to drop any of the seal fragments into the ink bottle. If the ink bottle is used with seal fragments inside, these may clog the bottle cap, preventing ink from being supplied.

3 Attach the bottle cap to the ink bottle.

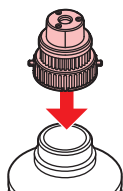



- Wipe off any ink or maintenance liquid remaining on the ink bottle or the bottle cap. Otherwise there is a risk of ink leakage due to loosening of the ink bottle cap.



- Check to confirm that there is no foreign matter, such as paper towel scraps or dust, adhering to the ink bottle caps. If foreign matter is present, this may block the ink path and lead to leakage.

4 Use the tightening jig to tighten the ink bottle caps in place.

Tightening tool

<p>[SPA-0232]</p> <p>Position the upper arrow within this range!</p>	<p>Good example</p>	<p>Bad example</p>
<p>[SPA-0328]</p> <p>Position the upper arrow within this range!</p>	<p>Good example</p>	<p>Bad example</p>



- Do not overtighten the ink bottle caps. Disregarding this precaution may result in damage, idling or ink leakage. If the arrow goes beyond the range indicated above, loosen the bottle cap, and repeat the steps again.
- Do not leave ink bottles with the ink bottle caps fitted for extended periods. Disregarding this precaution may result in the ink hardening.

5 Turn the ink bottle upside-down to check that no ink leaks occur.

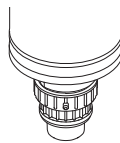

● **Mounting the ink**

The order of ink bottles to be set depends on the ink set you are currently using. Check the ink slot numbers and insert the correct color ink bottles.

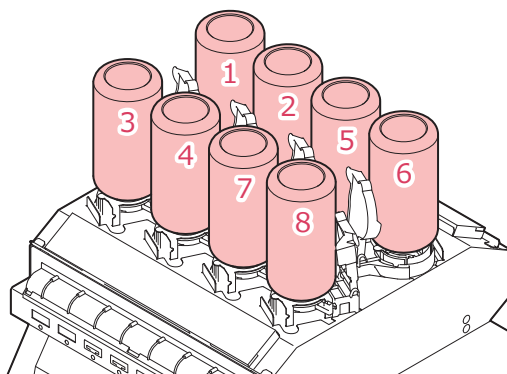

UJ330H-160		Ink positions							
Ink Type	Ink set	1	2	3	4	5	6	7	8
ELS-170/175	4-color	M	C	Y	K	K	Y	C	M
	4-color, W, Cl	M	C	Y	K	Cl	Cl	W	W
	6-color, W	M	C	Y	K	Lc	Lm	W	W
LUS-210	4-color	M	M	C	C	Y	Y	K	K
	4-color, W	M	M	C	C	Y	K	W	W

1 Insert the new ink IC chip into the ink IC chip slot.

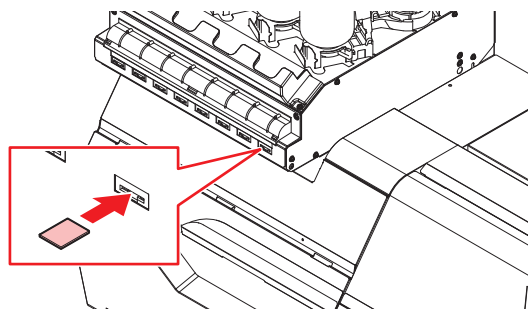

• Insert the ink IC chip with the metal side facing up. Inserting it in the wrong way may cause failure of the machine or damage the ink IC chip.



• Do not touch the metal parts of the ink IC chip. Static electricity may damage the ink IC chip, and dirt or damage may cause the ink IC chip read error.

2 Mount the ink bottles.

- Rotate the lever from the left to the right end, then mount the ink bottle.

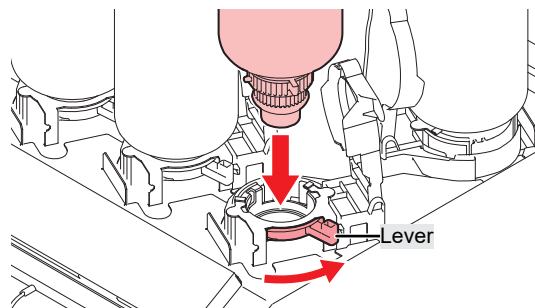



- You may apply the maintenance liquid onto the O-ring of the ink bottle caps so that the ink bottle can be inserted easily. Use the appropriate maintenance liquid to suit the ink being used.



3 Rotate the lever from right to left to secure the bottle in place.



- Never attempt to rotate the ink bottles. Doing so may result in leaking ink.



- Once the ink bottle is mounted, use up the ink as quickly as possible.

- Ink IC chips**: The marking on the ink IC chip indicates the color information.

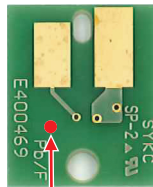

Marking locatio



- Insert the ink IC chip included in the package with the ink. The ink IC chip stores information such as the ink color, remaining amount, and expiration date. Printing is not possible if an incorrect ink IC chip is inserted.

Chapter 2 Printing



This chapter

This chapter describes printing procedures and settings.

Print Process	58	Auto-correction	90
Adjusting Print Head Height	60	Feed Correction.....	92
Loading the Media	62	Feed Correction Procedure.....	92
Media	62	Correcting the Drop Position	94
Media Feeding Belt	63	Drop Position Correction Procedure	94
Take-up unit	64	Preparing RIP data	96
Feeding unit	66	Printing	98
Loading the Roll Media	68	Changing the origin	98
Loading Rigid Media	72	Starting Printing	99
Resetting the media	81	Stopping Printing (Data Clear)	100
Registering the Media	83	Eject the rigid media	101
Test Printing	87	Pullback printing	102
Changing the Layout Direction for Test		When using pullback printing for register	
Printing	87	marks	102
Checking White Ink Ejection	88	If Mark Detection Fails	103
Ejection Failures.....	88	About 2.5D printing.....	105
Head Cleaning.....	89		

2.1 Print Process

Important!

- Please check the machine specifications and installation environment. [☞](#)
["Specifications"\(P. 182\)](#)
- If the installation environment does not satisfy the requirements, ink ejection consistency or media transport stability may be reduced. In particular, when performing high-density printing on roll media at low ambient temperatures, the media may lift up (wrinkles) due to shrinkage. [☞](#)
["The media jams or the media is dirty."\(P. 158\)](#)

1. Turn on the power.

[☞](#) ["Turning On the Power"\(P. 41\)](#)

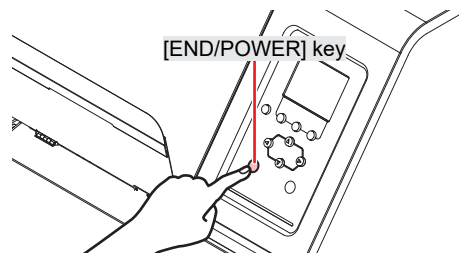

2. Connect a RIP PC to the machine.

[☞](#) ["Using a USB Cable"\(P. 45\)](#)

[☞](#) ["Using a LAN Cable"\(P. 44\)](#)

3. Setting Up RIP Software

[☞](#) ["Installing RIP Software"\(P. 47\)](#) (required first time only)

[☞](#) ["Obtaining Color Profiles"\(P. 47\)](#)

[☞](#) ["Setting Up RIP Software"\(P. 47\)](#) (required first time only)

4. Loading the Media

The machine can be used with roll media or rigid media. When loading the media, the print head height should also be set. [☞](#) ["Loading the Media"\(P. 62\)](#)

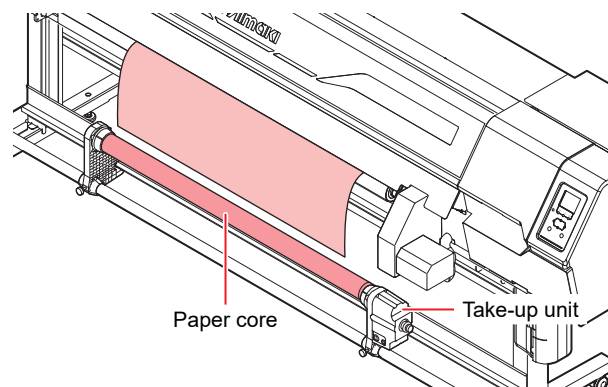

5. Check the state of the print head nozzles.

☞ "Test Printing"(P. 87)

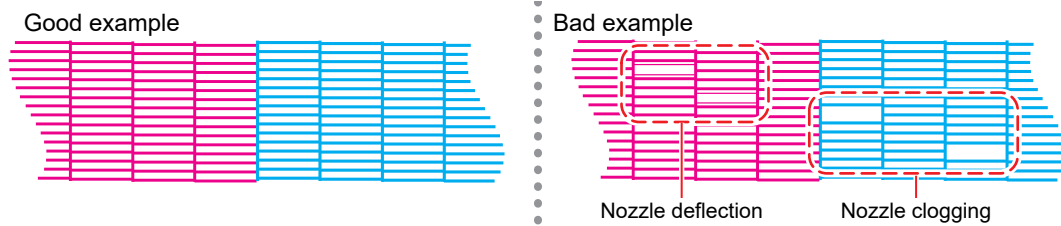

6. Clean the head to clear malfunctioning nozzles.

There are three different head cleaning methods. Choose the head cleaning method based on test print results. ☞ "Head Cleaning"(P. 89)

7. Adjust the media feed amount.

☞ "Feed Correction"(P. 92)

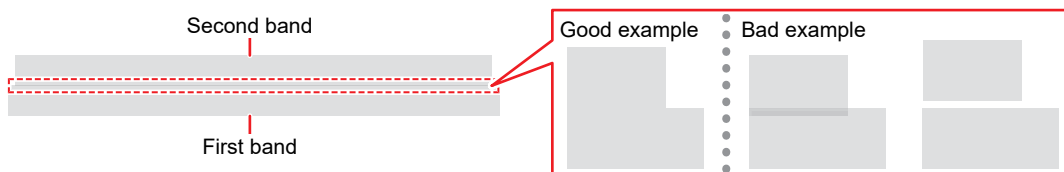

8. Adjust the drop position for bi-directional printing.

☞ "Correcting the Drop Position"(P. 94)

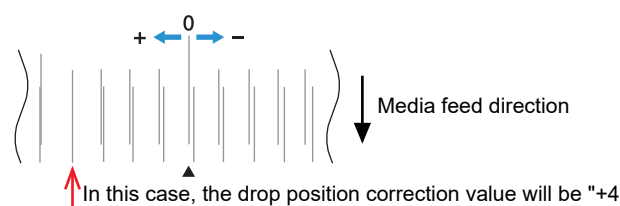

9. Preparing RIP data

☞ "Preparing RIP data"(P. 96)

10. Printing RIP data

☞ "Printing"(P. 98)

2.2 Adjusting Print Head Height



- With this machine, the print head height is set by raising or lowering the media feeding belt.

Adjust the height of the print head according to the thickness of the media you are using.

Range	Gap between print head and media
Low (recommended) to High	1.5 mm to 3.0 mm <ul style="list-style-type: none"> • Can be set in 0.1mm increments



- Be sure to correct the dot position after altering the print head height. ["Correcting the Drop Position"\(P. 94\)](#)



- A head gap of 1.5 mm should normally be used unless unavoidable. For this machine, the setting with a head gap of 1.5 mm provides the best print quality. If there is a risk of the head coming into contact with the media, perform printing with a wider head gap.
- With inkjet printers, if the gap between the print head and media increases, the ink droplets may vaporize before they reach the media.
- Vaporized ink will adhere to the print head nozzle surface, media, and UV-LED cooling fan filter. The amount of reflected light incident on the print head surface will also increase.
- Printing with a wide head gap poses a risk of reduced print quality in addition to the risks described above. In the area shown below, dot placement may become unstable due to the airflow from the suction fan.
 - 1) For roll media printing: The areas at the left and right edges of the media.
 - 2) For rigid media printing: The areas at the left and right edges, and the front and rear edges of the media.
 - 3) For multiple rigid media printing: The areas at the left and right edges of the media (including the gaps between each sheet), and the front and rear edges.
- To reduce irregular dot landing caused by airflow, consider the following measures.
 - Lower the suction fan setting.
 - Increase the margin size.
 - Install jigs around the media (in the case of rigid media).

● Media thickness settings

- The media thickness that can be set is as described in "Specifications". ["6.1 Specifications"\(P. 182\)](#)
- Larger media thickness settings (especially for media more than 10 mm thick) will tend to increase the amount of reflected UV-LED light incident on the nozzle surface. If ink adhering to the nozzle ejection surface hardens or becomes more viscous due to reflected UV light, this may cause offset ink ejection or nozzle clogging.
- Increasing the frequency of periodic maintenance around the nozzles or reducing the auto cleaning interval setting can help remove ink that has hardened or thickened on the nozzle surface. Placing jigs at each of the media edges in the same way as with borderless printing is also effective in reducing the amount of reflected UV-LED light. Conduct sufficient testing to determine the printing conditions that prevent nozzle clogging or deflection.

● Margin settings

- The (print) margins that can be set are as described in "Specifications". ["6.1 Specifications"\(P. 182\)](#)
 - Margin Setting ([P. 119](#))
- Smaller margin settings will tend to increase the amount of reflected UV-LED light incident on the nozzle surface. If ink adhering to the nozzle ejection surface hardens or becomes more viscous due to reflected UV light, this may cause offset ink ejection or nozzle clogging.

- Increasing the frequency of periodic maintenance around the nozzles or reducing the auto cleaning interval setting can help remove ink that has hardened or thickened on the nozzle surface. Conduct sufficient testing to determine the printing conditions that prevent nozzle clogging or deflection.

● Borderless printing

- When performing borderless printing, position jigs at each edge of the media to prevent ink mist from rising up and to minimize reflected UV-LED light. [☞ "About borderless printing"\(P. 74\)](#)
 - Place jigs with a width of at least 65 mm on the left and right sides of the media, and at least 10 mm at the front and rear, with a height equivalent to the media surface thickness (within 0.5 mm).
 - Take care to ensure that they do not come into contact with the carriage or the Y-bar.
 - Jigs taking into account the same precautions described above should also be used for the frames when performing borderless printing.

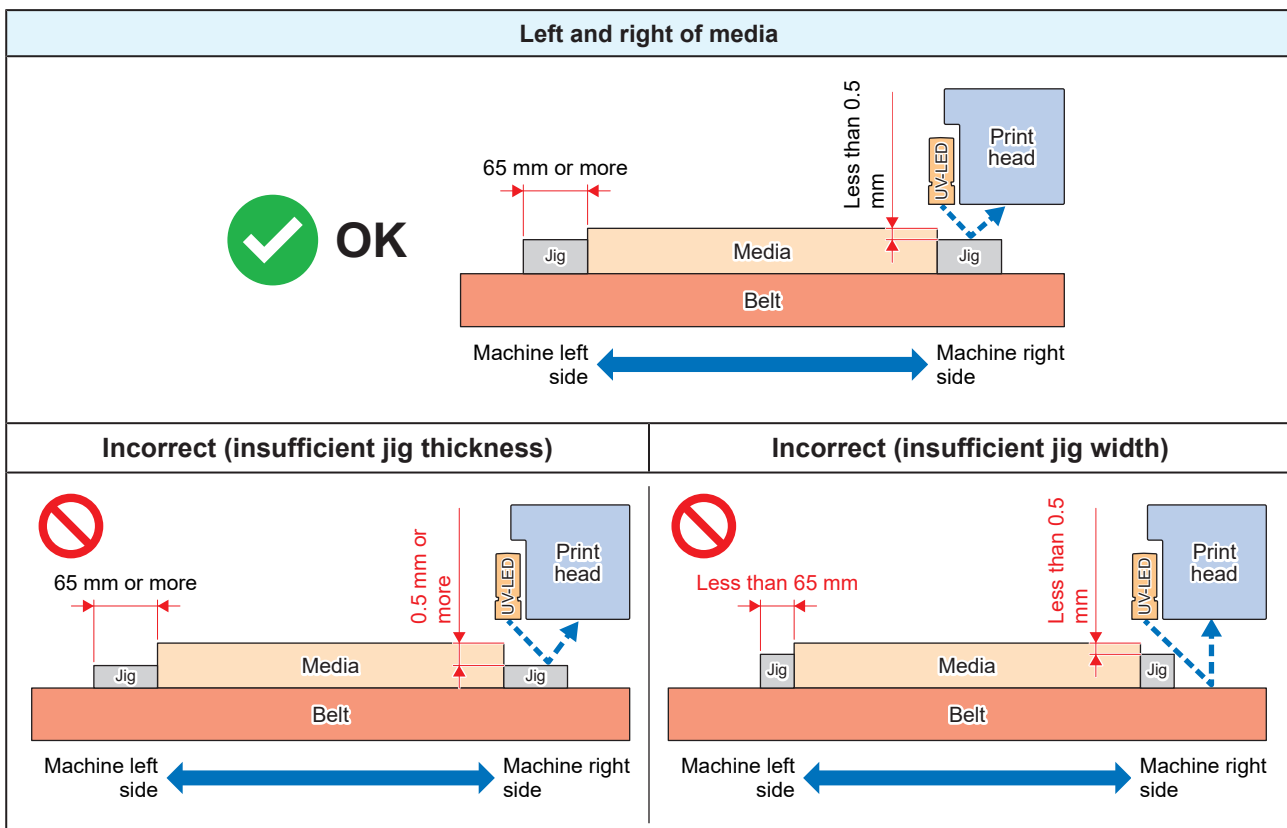

● When printing on media with curved edges

- When printing on media with curved edges, the curved edges must be covered.
 - If UV-LED light hits the curved surfaces, reflected light may scatter significantly.

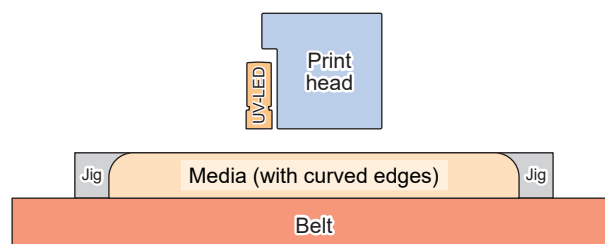

2.3 Loading the Media



- Adjust the head height before loading media. Moving the carriage after the media has been loaded may result in the print head coming into contact with the media and being damaged.

Media

● Media handling precautions



- Use Mimaki-approved media to ensure consistent high-quality printing.

WARNING



- Assign at least two people to load roll media. Otherwise there is a risk of back injury due to the weight of the media.

NOTICE



- Protect media from dust when stored. Otherwise print quality may be reduced.
- When storing standard-size media rolled up, store with the coated surface facing out.
- Static electricity countermeasures (such as ionizers, water mist humidification, and alcohol-based anti-static agents) should be provided for the media. Do not use anti-static agents that contain surfactants.



- Do not leave the media in the machine when not in use. Otherwise dust may accumulate on the media. Do not use media that has been wiped free of dust. Wiping media can generate static electricity, possibly affecting print quality.
- Do not use media immediately after removing it from the package. The media may expand or contract depending on the temperature and humidity of the location in which it was stored. Allow the media to stand for at least 30 minutes in the same indoor environment as the machine before loading it.
- Do not use media if it is curled. Curled media may not only damage the print head, but may also affect print quality.
- When using UV ink, do not use media that reflects light, such as media containing gold or silver foil. Light reflected from the media surface may cure the ink on the print head, damaging the head. Please note that this is not covered by the warranty.



- The underside of the media may be soiled depending on how the printed media has been stored (due to weight when laying printed media rolls horizontally, for example) and the media type. Perform a test beforehand to check that the media does not transfer ink to the underside of the adjacent media.

Media Feeding Belt

● Media feeding belt handling precautions

NOTICE



- The feed direction of the media feeding belt is indicated by the arrow (forward direction) in the figure below. To ensure consistent feeding accuracy, avoid using backward feeding to the extent possible. Backward feeding over long distances may adversely affect the feeding accuracy of the belt.

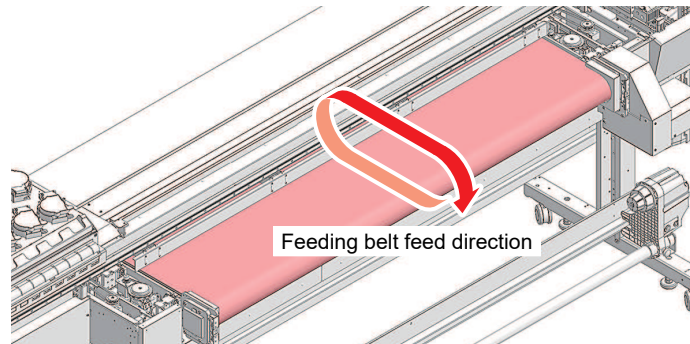

- Check to confirm that the edges of the media feeding belt are not frayed before loading the media. If the belt is frayed, cut off the frayed parts before loading the media. 📖 ["Checking State of Media Feeding Belt Edges"\(P. 134\)](#)

Take-up unit

Use the switch on the take-up unit to change the media take-up direction.

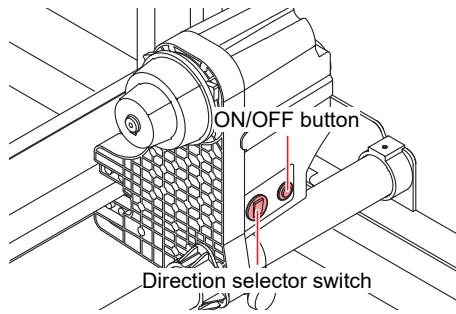

Name	Overview	
Direction selector switch	Up	To take up media with printed surface on the inside
	Down	To take up media with printed surface on the outside
ON/OFF button	Press the button to start/stop the take-up unit. The setting can be altered so that the take-up unit operates only while the button is depressed. Function Setting Menu	

Adjusting the torque limiter

The (right) take-up unit is fitted with a torque limiter.
Turn the torque limiter adjustment nut to adjust take-up tension.

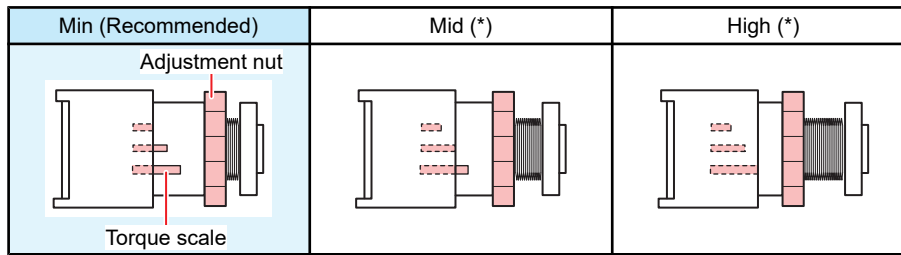

- For normal printing: Adjust the torque to "Low".
 - With this machine, the "Mid" and "Max" torque settings are not normally used. When using heavy media, the media take-up torque should be adjusted to "Mid" or "Max".
- Depending on the media, increasing the torque may cause image defects due to the feeding mesh belt vacuum not being able to grip the media. If the media slips, either reduce the torque setting or increase the vacuum fan strength setting. ["Media Setting Menu"\(P. 108\)](#)

● Increase tension (clockwise)

Increase tension when using with heavy or thick media, such as tarpaulin. Perform adjustments manually.

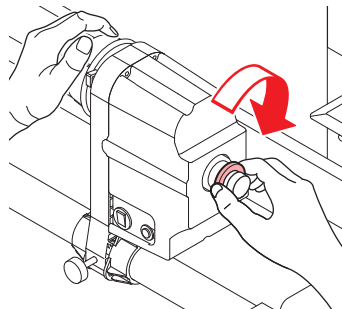

- Do not use the torque adjustment handle. Using the torque adjustment handle will cause overtightening. Overtightening may damage the take-up unit.

● Decrease tension (counterclockwise).

Decrease tension when using lightweight media. Use the "torque adjustment handle" provided.

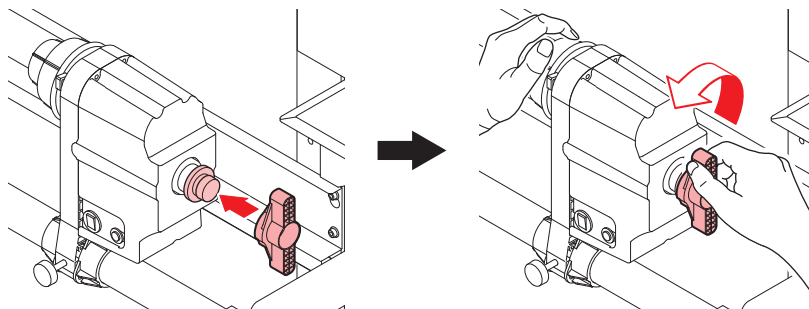

Feeding unit

Using the Media Stopper

When pulling out a fixed length of media by hand, the roll holder locks, stopping the media from being pulled out.

● Lock the media stopper

Push the side pin while pressing on the media stopper. Releasing the media stopper in this state locks the roll holder.

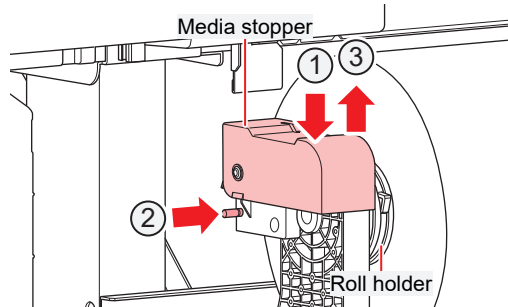

- Be sure to lock the media stopper when loading roll media or printing.

● Release the media stopper

Press the media stopper to release the roll holder.

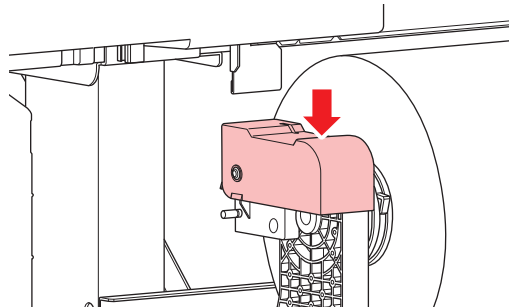

Roll holder setting position

Loosen the knob screw on the rear left roll holder, then move it to the roll setting position.

A label showing the roll holder setting position is placed on the leg stay. Use it as a reference to move the roll holder, then secure using the knob screw.

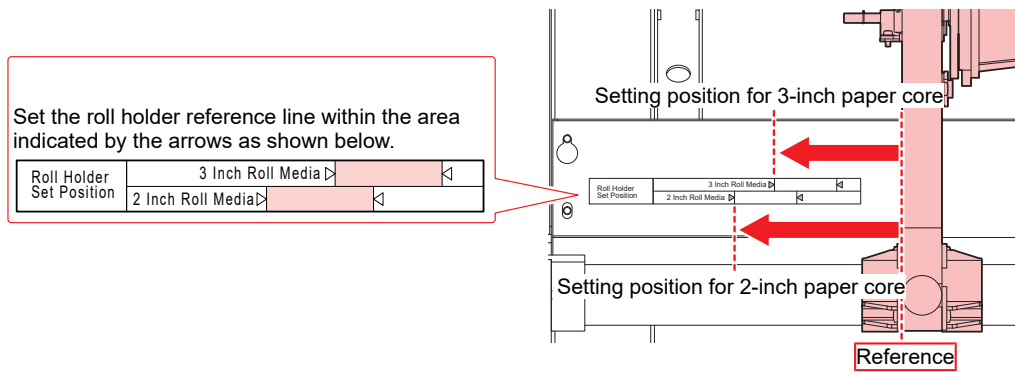

- The setting position is the center reference position.

Loading the Roll Media

1 On the Local screen, select [Start Media Set].

2 Select the media to be used.

Media selection	1/2
<input checked="" type="radio"/> PVC	1300 mm
<input type="radio"/> Tarpaulin	1600 mm
<input type="radio"/> Unregistered	
<input type="radio"/> Unregistered	
<input type="radio"/> Unregistered	



- To use unregistered media, select [Unregistered] to register the media. ["Registering the Media"\(P. 83\)](#)

3 Select roll media, then follow the settings.

- The media feeding belt moves up or down.



- Pay particular attention to the media thickness setting. If this is set incorrectly, the media may be damaged or a machine error may occur when the media feeding belt is raised or lowered.
- Do not place your hands or objects on top of the media feeding belt. There is a risk of injury when the media feeding belt is raised or lowered.

4 Once raising or lowering is complete, the message [Set a media] is displayed.

5 Move the rear left roll holder to the roll setting position.

- Unscrew the roll holder retaining screw, move the roll holder, then retighten the retaining screw. ["Roll holder setting position"\(P. 67\)](#)

6 Insert the paper core of the roll media on to the rear left roll holder.

- Push in until the paper core moves no farther.

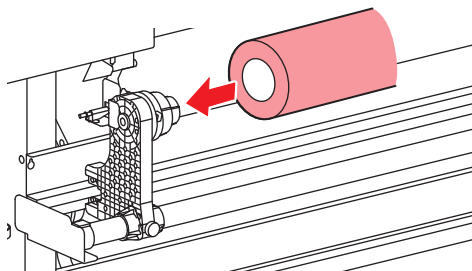

7 Insert the rear right roll holder into the paper core.

- Unscrew the roll holder retaining screw, move the roll holder, then retighten the retaining screw.

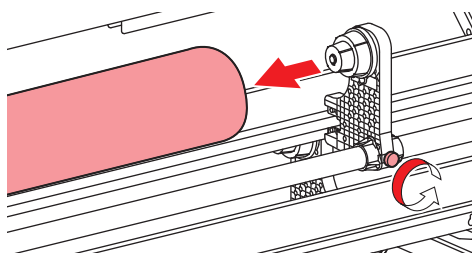

8 Insert the media between the media feeding belt and the Y-bar.

9 Lock the media stopper.

-  "Using the Media Stopper"(P. 66)

10 Move to the front of the machine and open the front cover.**11 Pull out the media.**

- Make sure the media does not fall to the rear.

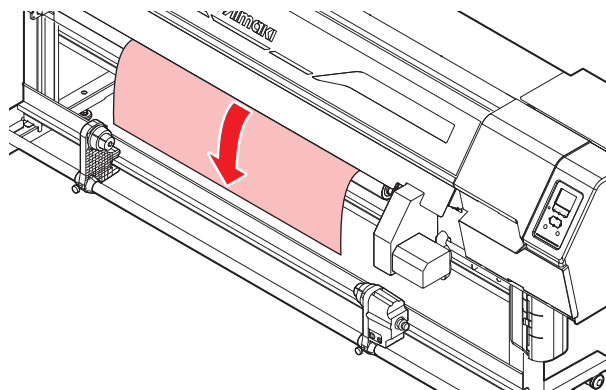

- The [VACUUM] key or rear switch can be used to turn the media vacuum fan on and off.
- If the media is stuck to the media feeding belt and difficult to pull out, turn off the media vacuum fan first.
- The margins on both sides of the media can be varied by selecting [Function Setting] > [Margin Setting] > [Margin], then altering the setting.

12 Gently pull out the media and stop at the position where it is gently locked in place.**13 Check how far the media was pulled out.**

- Pull the front edge of the media gently at several points to confirm that the media was pulled out by the same amount.

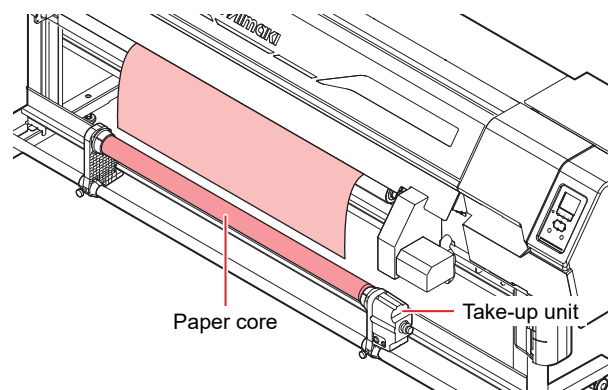

14 Load an empty paper core on the take-up unit.**15 Close the front cover.****16 Press the [Enter] key on the [Set a media] screen once the media has been loaded.**

17 The media width is detected.

- No change: Only the right side of the media is detected.
- Media width re-detection: The media width is detected.

PVC	
Media Width	1300 mm
(printable width)	1270 mm
	No change
	Media width re-detection



- Media width may not be detected correctly for certain colors or types of media. When media width cannot be detected correctly, set the media width detection method to "MANUAL".
- If the media width detection method is set to "MANUAL", set the media width manually ([MENU] > [Media Setting] > [Media Information] > [Media Detect] > [Detection Type]  P. 109).
- A notification reading "Media Set Position R" will appear after media width detection if the media is too far to the right of the specified position. Reload media in the specified position.
- If Media Remain Manage is set to "ON", the Input Media Length screen will be displayed. ([MENU] > [Media Setting] > [Media Information] > [Media Remain] > [Media Remain Manage]  P. 109).

18 Press to feed the media until it reaches the paper core on the take-up unit, then press the [ENTER] key.

19 Secure the middle of the media to the paper core with adhesive tape.

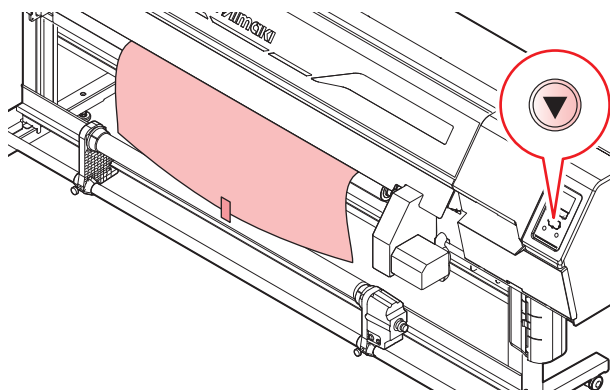

- If the media edge is straight, secure the left and right sides of the media. Pull the lower edge of the media evenly on both the left and right sides, check to confirm that it is free of sagging and creasing, then affix the tape.

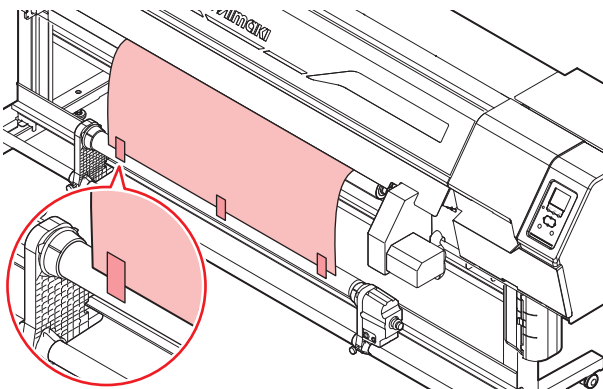

20 Press  to wrap the media about one and a half turns around the paper core, then press the [ENTER] key.



- Move the take-up unit to the left or right when it is not in use. Print quality may be affected if the front edge of the media hits the take-up unit.

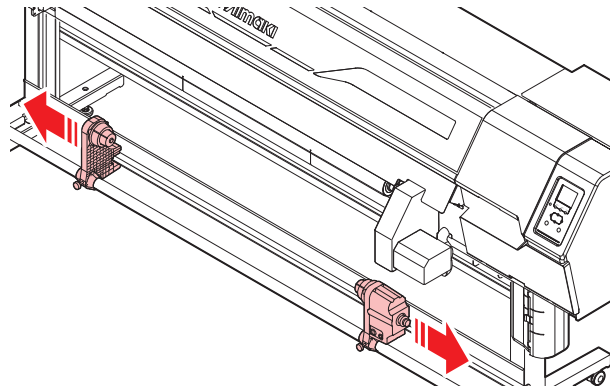

Loading Rigid Media

● Information about loading rigid media



- Check to confirm the specifications of media that can be loaded. ["Specifications"\(P. 182\)](#)
- The machine grips and feeds the media using vacuum force generated by a fan. If rigid media is warped in a convex shape rather than concave, suction efficiency increases, enabling the media to be fed with greater accuracy.



- It is important that rigid media is flat with no variations in thickness. If there is significant warping, the media may come into contact with the head, or media feeding and printing may not be performed correctly.
- There is a risk that the media may become scratched due to friction during transport. For media that is prone to surface scratches, such as acrylic boards, we recommend printing with the scratch-resistant protective film still attached to the back of the media.
- Static electricity on the media may cause problems such as marks left from the rear clamp roller or abnormal printing. Such problems are more common particularly with acrylic media and media from which the protective paper has just been removed, causing static charging. Consider using any of the following three methods to prevent static electricity:
 - (1) Use of an ionizer
 - (2) Water mist humidification
 - (3) Alcohol-based anti-static agent



- When printing on rigid media, it is important that the media be accurately rectangular. The ideal conditions are that the front edge is cut straight and the corners are at right angles.
- Be sure to place the media in the center of the conveyor belt. If the media is not centered, the "media thickness compensation" function may not work properly, which could cause damage to the machine.

● About Printing on Rigid Media

Depending on the length of the rigid media being loaded and the type of printing, it may be necessary to set up the media feed tray. Also, when printing multiple copies, please be mindful of the printable media width. Please refer to the table below to confirm the number of conveyor sets and any precautions.

Length of the rigid media to be installed	During normal printing		Clear Gloss Printing/ When printing in reverse	
	Media Set of 1	Media Set of Multiple Pieces	Media Set of 1	Media Set of Multiple Pieces
~450 mm	(5)	(5)	(6)	(4), (6)
~1300 mm	(1)	(1), (4)	(1)	(1), (4)
~2500 mm	(2)	(2), (4)	(2)	(2), (4)
~3100 mm	(3)	(3), (4)	(3)	(3), (4)

Important Notes When Setting Up Media

- (1): Place media conveyors in front of and behind the machine.
If you plan to use the Roller Table Assy (Mimaki option), you will need one set.
- (2): Place media conveyors in front of and behind the machine.
If you plan to use the Roller Table Assy (Mimaki option), you will need two sets.
- (3): Place media conveyors in front of and behind the machine.
If you plan to use the Roller Table Assy (Mimaki option), you will need three sets.

(4): Make sure the width of the media you are loading is less than the width of the media feed trays located at the front and rear of the machine.

There is a risk that the media may fall off the transport tray after printing.

(5): When aligning the media against the positioning bar during media setup, depending on the length and type of the media, there is a risk that the media may fall out.

In that case, please position the media conveyor at the rear of the machine.

(6): When adding media during clear gloss printing or performing a backfeed during reverse printing, depending on the length and type of the media, there is a risk that the media may fall out.

Please place media conveyors at the front and rear of the machine.

● About the vacuum fan strength setting

The machine allows the vacuum strength setting to be changed as desired ([Menu] > [Media Setting] > [Detail Setting] > [Vacuum]).



- The following types of media carry a risk of feeding problems, so it is recommended that the **vacuum setting be set to "Strong"**.
 - Large size media
 - Heavy media
 - Slippery media



- Test the media in advance to confirm that feeding problems do not occur.

● About multiple sheet printing

The machine supports multiple sheet printing, in which the same data is printed on multiple sheets of identical rigid media arranged side by side. The maximum number of prints is 7 (hereinafter, the illustrations will be based on a print run of 3).



- When loading multiple sheets of rigid media side by side, the media sheets must be loaded without any gaps between them. Once the media has been loaded, enter the number of sheets on the operating panel. ["Rigid media loading procedure"\(P. 75\)](#)

● **About borderless printing**

The machine is capable of printing up to the edges of the media (with no margins) by placing frame jigs at each edge. The frame jigs must be prepared to match the media size and must also meet the specified dimensions.

Once the media has been loaded, create the image data taking into account the frame jig dimensions, and then print.

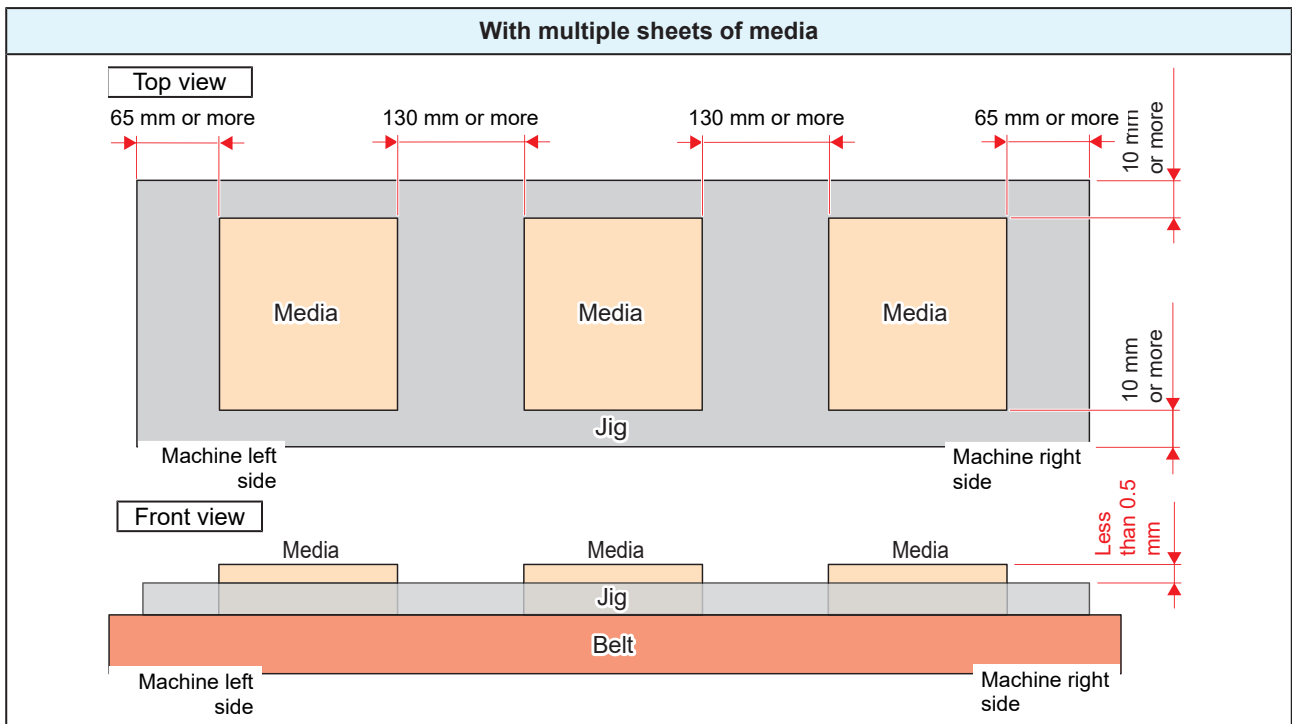
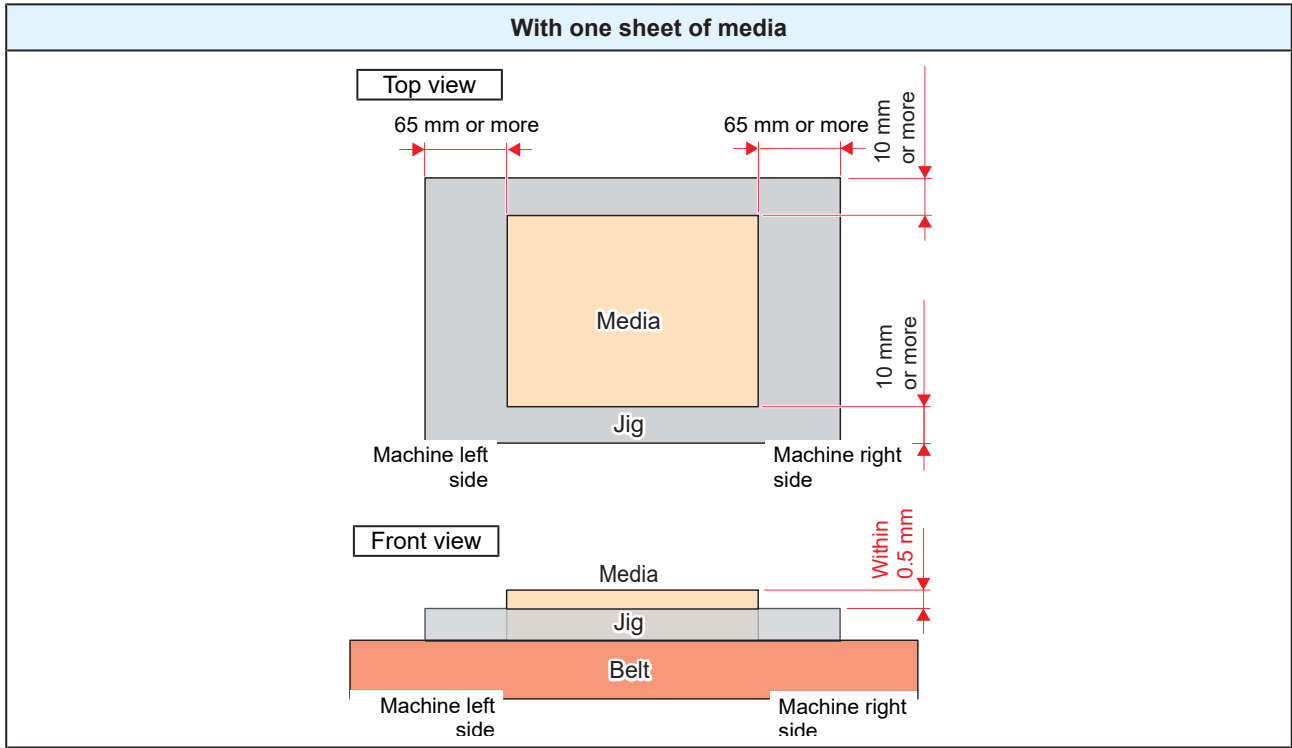

Rigid media loading procedure



- When using the Roller Table Assy (option):
 - (1) Place the Roller Table Assys at the front and rear of the machine.
 - Align the roller direction of the feeding unit with the feed direction of the media feeding belt, ensuring that they are parallel.
 - (2) The Roller Table Assy setting bar included with the Roller Table Assy can be used to install the Roller Table Assy in the correct direction and at the correct distance relative to the machine.

1 On the Local screen, select [Start Media Set].

2 Select rigid media, then follow the settings.

- The media feeding belt moves up or down.



- Pay particular attention to the media thickness setting. If this is set incorrectly, the media may be damaged or a machine error may occur when the media feeding belt is raised or lowered.
- Do not place your hands or objects on top of the media feeding belt. There is a risk of injury when the media feeding belt is raised or lowered.

3 Once raising or lowering is complete, the message [Set a media] is displayed.

Media 1	
to take-up	
Completed	[ENT]
Bar: Down	

4 Once you have confirmed that the positioning bar has lowered, insert the rigid media into the ▼ mark in the center of the back of the machine, and align the leading edge of the media with the positioning bar.



- When using media with backing paper, this may become charged when the film is peeled off, possibly causing ejection abnormalities. Use an anti-static brush or similar to remove any static charge from the media before placing it on the feeding unit.

Important! When using Roller Table Assy (option):

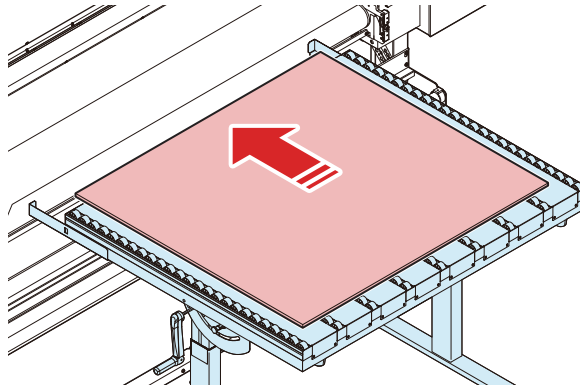

- Align the height of the Roller Table Assy with the height of the media feeding belt on the machine. If there is a large difference in the height of the Roller Table Assy, the media will lift up on the media feeding belt, preventing it from being fed correctly.
- When printing multiple sheets, place the media on the Roller Table Assy side by side without any gaps. You can load up to 7 sheets of media at a time (hereinafter, the illustrations will use a 3-sheet print job as an example).

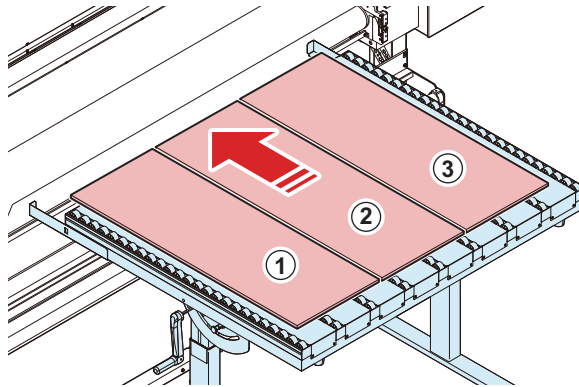

- While the rigid media should ideally be a precise rectangle in shape, in practice, some media may not be exactly rectangular, so pay attention to the following points when loading multiple sheets of media for printing.

OK	No good
<p>Media Media Media</p> <p>Setting bar</p>	<p>Media Media Media</p> <p>Gap</p> <p>Setting bar</p>
<p>1. When loading the media, it is most important that the media is pushed up flush against the setting bar.</p> <p>2. Hold (1) and arrange side by side without any gaps between the sheets where possible.</p> <p>(1) is more important than (2).</p>	<p>If printing is started with priority placed on (2), the print results will be tilted.</p>

Important!

- Media placement (left and right positioning)

The rear clamp rollers press down on the media from above to prevent it from making contact with the underside of the carriage if it is warped.

Since the edges of the media are most susceptible to warping, adjust the media position (left and right) so that this roller is positioned as close as possible to the left and right edges of the media.

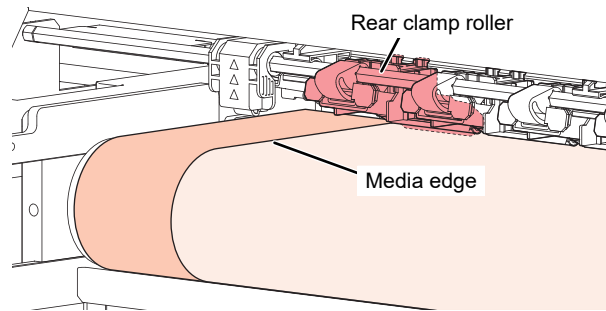

With one sheet of media		
OK		No good
<p>The left and right positioning can be adjusted so that the rollers press down on the edges of the media and minimize media warping.</p>		<p>Set the media so that the edges are not positioned in a way that prevents them from being held down by the rollers. * Depending on the media width you set, there may be cases where this is unavoidable.</p>

With multiple sheets of media		
OK		No good

With multiple sheets of media	
OK	No good
Adjust the position of the media (left and right positioning) to ensure that the rollers press down on the edges of the media to the extent possible.	Set the media so that the edges are not positioned in a way that prevents them from being held down by the rollers. * Depending on the media width you set, there may be cases where this is unavoidable.



- The rear switch can be used to raise and lower the positioning bar.

5 Move to the front of the machine.

6 Press the [Enter] key on the [Set a media] screen once the media has been loaded.

Media 1	
to take-up	
Completed	[ENT]
Bar: Down	

7 The rigid media is fed to the front of the machine.

- Check to confirm that the rigid media is fed correctly here.



- If it is not fed correctly, this may be due to one of the following causes. Check the situation.
 - (1) The media was not pushed up against the positioning bar.
 - (2) The media is too heavy.
 - (3) The media is a slippery material.
 - (4) There is an obstruction impeding media feeding on the media feeding path.
 - (5) If using Roller Table Assy (option), the height of the Roller Table Assy does not match the height of the media feeding belt.

8 Set the power lock rollers.

Media 1
Open the front cover and Power lock roller set the Power Lock Roller.unit. When not in use, press [ENER].

- When using the power lock rollers, open the front cover, then position the power lock rollers to cover both edges of the media.
- If not using the power lock rollers, press the [Enter] key.

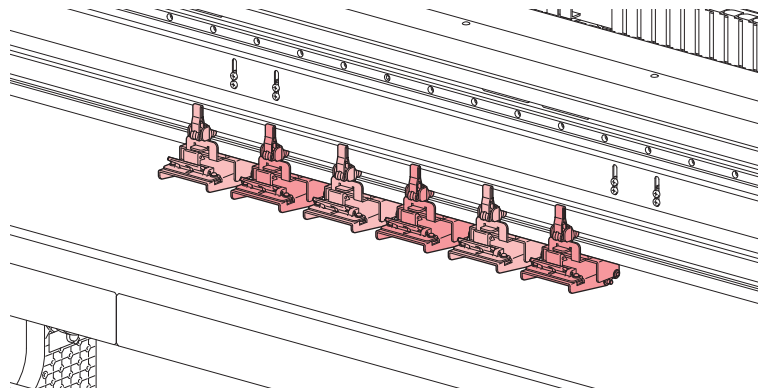

- The power lock rollers are used when printing on warped rigid media. When printing on rigid media without warping, leave all of the power lock rollers in the raised position.
- Do not use the power lock rollers when printing on roll media. Leave all of the power lock rollers in the raised position.

- Power lock roller setting procedure

(1) Lower the lever, then move the power lock roller.

- Position it so that it holds down the edge of the media, then raise the lever to lock it in place.

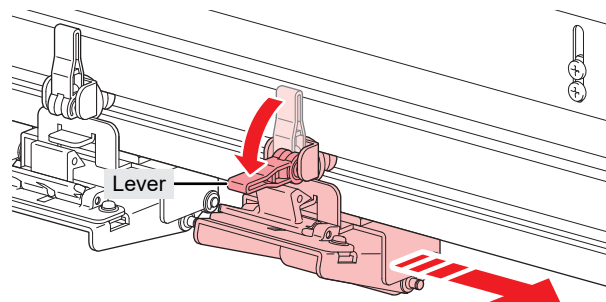

- (2) Power lock rollers that are to be used should be used with the roller lowered.
- Press the knob to release the hook and lower the roller.

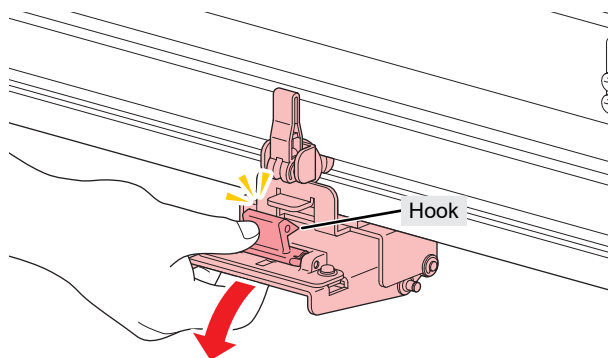

- (3) For power lock rollers that are not used, engage the hook on the base to keep the roller raised.

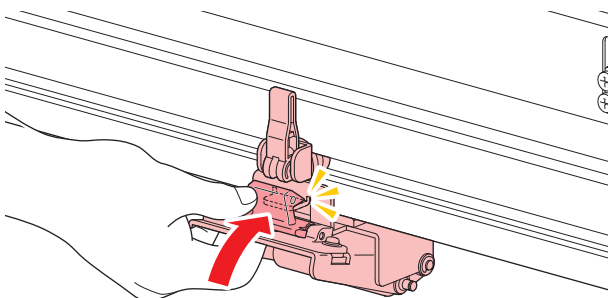

- The power lock rollers are used when you wish to minimize warping at the rear edge of the media. Use them when printing media with significant warping.
- When only one sheet of media is loaded, only two power lock rollers should be used. Move any unused power lock rollers to the far left and right ends.

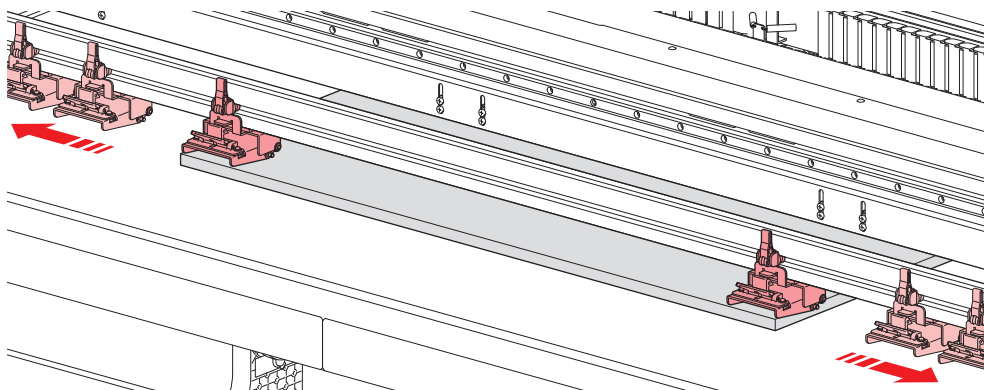

9 Set the media thickness correction.

- [Perform media thickness correction?] will be displayed.



- Media thickness correction is a function which automatically measures the media thickness and then corrects the registered media thickness information. It is recommended that this be used when the exact thickness of the loaded media is not known.

- To use the media thickness correction feature, select [Execute] and press the [ENTER] key.

10 Select the measurement location for the media thickness.

- Automatic: Measures near the center of the belt.
- Manual: Take a measurement at any desired location.
Use ◀ ▶ to move the carriage left and right and specify the measurement position.

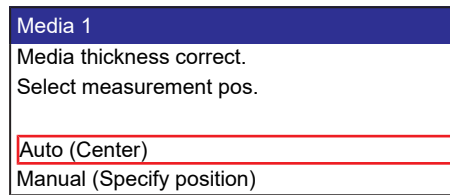
**11 The carriage moves and the media thickness is be measured by the length measurement unit.****12 The measured value is displayed on the screen.**

- After checking, press the [ENTER] key to exit media thickness correction.

13 The media width is detected.

- No change: Only the right side of the media is detected.
- Media width re-detection: The media width is detected.

PVC	
Media Width	1300 mm
(printable width)	1270 mm
	No change
	Media width re-detection

14 The media width is detected followed by the media front edge.

- Media width and the front edge may not be detected correctly for certain colors or types of media. When the media width and front edge cannot be detected correctly, set the media detection method to "MANUAL".
- If the media detection method is set to "MANUAL", set the media width and media front edge manually ([MENU] > [Media Setting] > [Media Information] > [Media Detect] > [Detection Type] P. 109).
- A notification reading "Media Set Position R" will appear after media width detection if the media is too far to the right of the specified position. Reload media in the specified position.
- When the media detection method is set to "MANUAL", set the media right edge, left edge, and front edge using the LED pointer. Pressing the [FUNC2] key here lowers Z by a preset amount, making the LED pointer easier to see. Pressing the [FUNC2] key again raises Z to its original position.

15 Set the number of media sheets.

- Set the number of media sheets arranged sideways between 1 and 3.
- This setting can also be altered using [Media Setting] > [Media Information] > [Media Count].

Resetting the media

- 1** On the LOCAL mode screen, select [MEDIA].

2 Select Media Reset.

Media Reset / Eject	
Media Reset	>
Rigid Media Eject	>

3 On the Media Reset screen, press the [ENTER] key to cancel the media set status.

Media Reset	
Start	[ENT]



- Removing the media without resetting it first may prevent correct media monitoring.
-

Registering the Media

On the Local screen, select [Start Media Set]. The Select Use Media screen is displayed. Registration is required to use media that is not registered on the machine.



- To set print conditions for a single use, select "Temporary". The conditions set in "Temporary" are cleared when the machine is restarted.

● Procedure

1 Select [Unregistered].

Media selection	1/2
<input checked="" type="radio"/> PVC	1300 mm
<input type="radio"/> Tarpaulin	1600 mm
<input type="radio"/> Unregistered	
<input type="radio"/> Unregistered	
<input type="radio"/> Unregistered	

2 Select the media type.

Media Type
<input checked="" type="radio"/> PVC
<input type="radio"/> Tarpaulin
<input type="radio"/> Transfer paper
<input type="radio"/> Illuminated Film
<input type="radio"/> Cutting Sheet
<input type="radio"/> Rigid
<input type="radio"/> Clear Rigid



- When using acrylic rigid media, select "Clear Rigid". Also, [Auto Media Detection] will not be performed with clear media unless this is selected. To execute [Auto Media Detection], please use one of the following methods.
 - Use the white frame jig.
 - Apply white tape to the front-left and front-right corners on the back of the media. (However, depending on the thickness of the media, it may not be detected.)
 - Apply white tape to the front-left and front-right corners of the media surface. (Although this improves detectability, please position the data so that it does not get printed on the tape.)

Affix tape corresponding to the following dimensions along the edges of the media.

- Longitudinal direction: At least 30 mm
- Horizontal direction: At least 10 mm

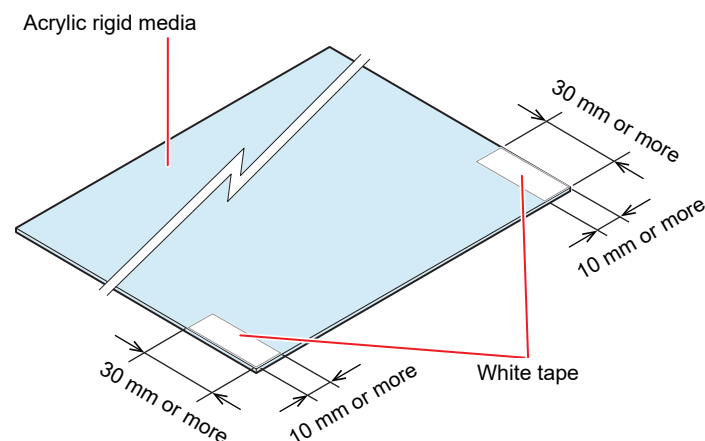

● When using roll media

1 Set the head height (gap) and media thickness.

Head height	
Head gap	1.5 mm
Media thickness	0.0 mm

- Once the media has been registered, the media feeding belt moves up or down in accordance with this setting.

2 Select the media width detection type.

- AUTO: The media width is automatically detected.
- MANUAL: The media width is manually set.

Select media detection type	
	AUTO
	MANUAL



- Media width and the front edge may not be detected correctly for certain colors or types of media. When the media width and front edge cannot be detected correctly, set the media detection method to "MANUAL".

3 Select the method for managing the media remaining amount.

- Select whether or not to manage the media remaining amount with the machine.

Media Remain Manage	
Please Select.	
	ON
	OFF

4 Enter the name to be displayed.

- If you do not register the name, press the [ENTER] key.

Media Name Change	
Media 3	
will be changed	
(maximum 10 characters)	

5 Select whether or not to register the set information.

do you optimize setting?	
	Execute
	Do not



- ["Media optimization settings"\(P. 86\)](#)
- You can change the settings later. ["Media Setting Menu"\(P. 108\)](#)

● When using rigid media

1 Set the head height (gap) and media thickness.

Head height	
Head gap	1.5 mm
Media thickness	0.0 mm

- Once the media has been registered, the media feeding belt moves up or down in accordance with this setting.

2 Select the media width and media front edge detection type.

- AUTO: The media width and front edge are automatically detected.
- MANUAL: The media width and front edge are manually set.

Select media detection type	
	AUTO
	MANUAL



- Media width and the front edge may not be detected correctly for certain colors or types of media. When the media width and front edge cannot be detected correctly, set the media detection method to "MANUAL".

3 Set the vacuum fan strength.

- If the media is warped or problems occur with feeding accuracy, select [High].

4 Set whether the rear clamp rollers are used.

- If the media is warped or problems occur with feeding accuracy, select [Yes].

Media 1	
Use rear clamp rollers?	Yes No

5 Enter the media length.

- The printable length is automatically set to a value corresponding to the media length - 10 mm.

Media length	300 mm
(printable length)	290 mm

6 Enter the name to be displayed.

- If you do not register the name, press the [ENTER] key.

Media Name Change	
Media 3	
will be changed	
(maximum 10 characters)	

7 Select whether or not to register the set information.

do you optimize setting?	Execute Do not
--------------------------	-------------------



- "Media optimization settings"(P. 86)
- You can change the settings later. "Media Setting Menu"(P. 108)

Media optimization settings



Optimizing the settings sets the various items as follows, depending on media type:

Settings	Default	Tarpaulin	PVC	Synthetic paper	Film	Cutting sheet	Rigid	Transparent Rigid
UV Light Intensity Adjustment (%)	0	0	0	0	0	0	0	0
MAPS	Auto	Auto	Auto	Auto	Auto	Auto	Auto	Auto
Feed speed (%)	Host	100	100	100	100	100	100	100
Work Change (Rigid and Transparent Rigid Only)	-	-	-	-	-	-	ON	ON

2.4 Test Printing

Print a test pattern to confirm that the ink prints correctly. Perform head cleaning if you observe any ejection failures (e.g., nozzle clogging or deflection).  ["Head Cleaning"](#)(P. 89)

Check beforehand

- Was the print head adjusted?  ["Adjusting Print Head Height"](#)(P. 60)
- Is media loaded?  ["Loading the Media"](#)(P. 62)



- Load media at least 500 mm wide. You cannot print the entire pattern if media less than 500 mm wide is used.



- Select [Maintenance] > [Nozzle Recovery] > [Test Print], then select "ON" to perform nozzle recovery and test printing.
Registration is required to perform nozzle recovery.  ["Registering Nozzle Recovery"](#)(P. 114)

Changing the Layout Direction for Test Printing

You can change the layout direction for test printing.

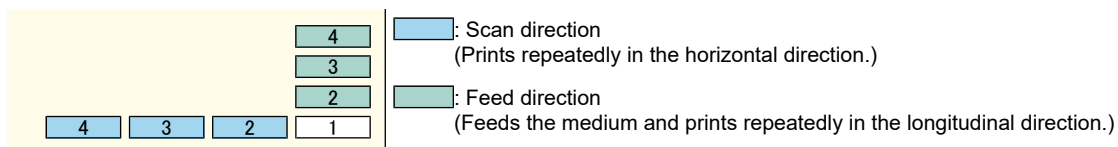

- 1** On the LOCAL mode screen, select [TEST PRINT/CLEANING] > [Test Print], then press the [ENTER] key.
 - The Test Print menu is displayed.
- 2** Select [Scan Dir.] or [Feed Dir.], then press the [ENTER] key.
 - Test printing starts.

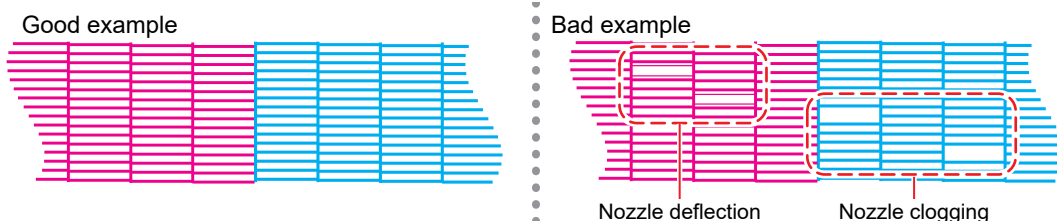

- 3** Check the print results.

Checking White Ink Ejection

The following two methods are available for checking white ink:

- Print on clear film.
- Print the background for the test pattern using black ink.

● Method for printing the background using black ink

- 1** On the LOCAL mode screen, select [TEST PRINT/CLEANING] > [Test Print], then press the [ENTER] key.
 - The Test Print menu is displayed.
- 2** Select [SpotColor Check], then press the [ENTER] key.
 - Test printing starts.
 - The layout direction is fixed at [Scan direction].

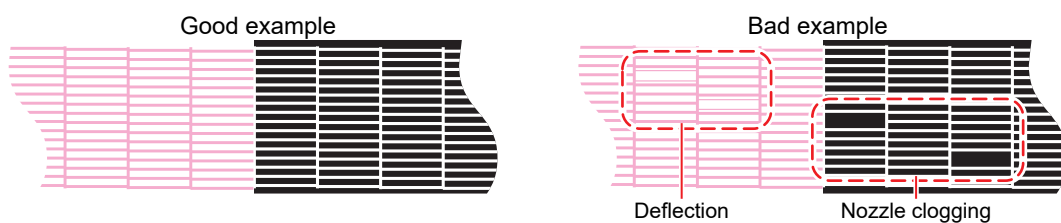

- 3** Check the print results.

Ejection Failures

Typical examples of ejection failures (e.g., nozzle clogging, deflection) are as shown below. In order to prevent printing in such a state, check whether the ink has been properly ejected regularly before printing.

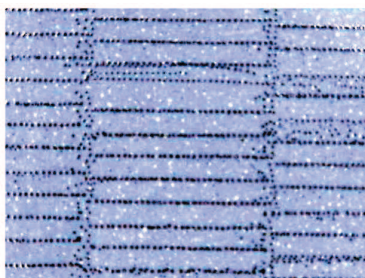

Nozzle Deflection

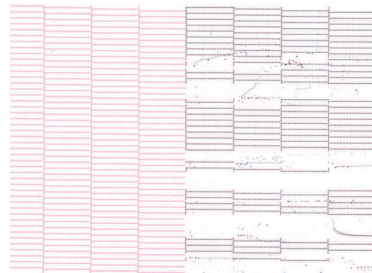

Nozzle clogging



Ink drips



Mist

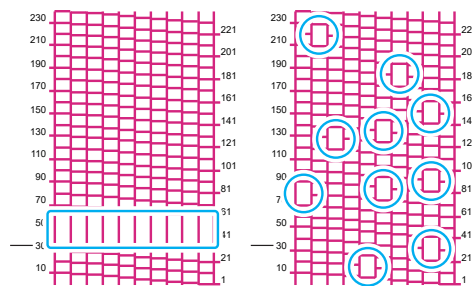

Mixed air

2.5 Head Cleaning



The following head cleaning methods are available. Choose the method based on test results. Cleaning is not possible when the [Ink Near End] or [Ink End] errors are displayed. Replace with new ink.  ["Replacing Ink"\(P. 50\)](#)

Item	Details
Soft	If the print shows a bent line (Nozzle deflection)
Normal	If the print shows a missing line (nozzle clogging)
Hard	If soft cleaning and normal cleaning fail to resolve ejection failures (e.g., nozzle clogging or deflection).
High Power	When chronic color mixing cannot be remedied. <ul style="list-style-type: none"> Selecting the applicable head increases the power for each cleaning mode. This should remedy color mixing issues.







- The ink used in the machine is warmed before printing. Printing and cleaning is disabled while the ink is being warmed.



- If a specific ink has caused extensive nozzle clogging (dropouts), please refill that ink individually.  ["A large amount of a specific ink caused nozzle clogging"\(P. 165\)](#)
- If there is a large amount of white ink causing nozzle clogging (major clog) and refilling individual ink cartridges does not resolve the issue, please bleed the system.  ["There is considerable nozzle clogging with white ink"\(P. 164\)](#)

- 1 On the LOCAL mode screen, select [TEST PRINT/CLEANING] > [Cleaning], then press the [ENTER] key.**
 - The Cleaning menu is displayed.
- 2 Select the cleaning type, then press the [ENTER] key.**
- 3 Select the Head to clean, then press the [ENTER] key.**
 - Check the check box. Heads with checked check boxes will be cleaned.
- 4 Run another test print and check the print results.**
 - Repeat the cleaning and test printing process until the print results appear normal.



- Do the following if head cleaning fails to resolve the ejection failures (e.g., nozzle clogging or deflection).
 -  ["Cap Rubber Cleaning"\(P. 127\)](#)
 -  ["Cap Suction Check"\(P. 116\)](#)
 -  ["Print Head Nozzle Washing"\(P. 163\)](#)
- Perform the following steps if an abnormal noise is heard during cleaning:
 -  ["Abnormal noise occurs during cleaning"\(P. 167\)](#)

2.6 Auto-correction

The auto-correction function (DAS2: Dot Adjustment System 2) detects a correction pattern with the sensor and automatically corrects the drop position.

● Overview

Auto-correction includes the following functions:

- All
- Feed Comp.
- Drop.PosCorrect (All, 600Std, 600Hi, 1200Std, 1200Hi)



- Note the following precautions when using auto-correction.
 - (1) Check to confirm that the media does not lift up.
 - (2) Load clean media.
 - (3) Use media that is at least 370 mm wide.
 - (4) Media such as synthetic paper, tarpaulin, or cloth media may not be detected.
 - (5) Do not send RIP data from the PC during pattern printing.

● Procedure

- 1 On the LOCAL mode screen, select [ADJUST].

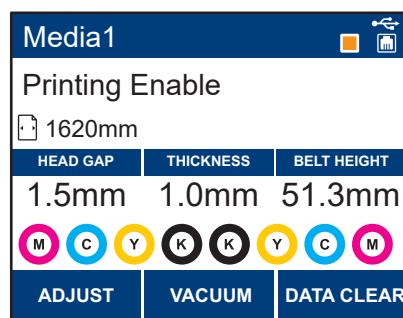

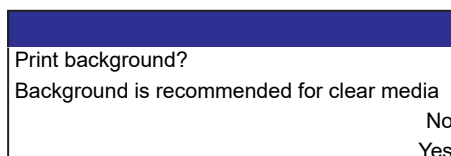

- 2 Select [Auto-correction], then press the [ENTER] key.
- 3 Select the function to be used, then press the [ENTER].
- 4 For Drop.PosCorrect, select the resolution, then press the [ENTER] key.
- 5 Select whether the background is to be printed, then press the [ENTER] key.
 - The following screen is displayed only when using an ink set including white.





- 6 Press the [ENTER] key to start adjustment.
 - [Print] > [Pattern Detect] > [Correction] is performed for the pattern.



- If automatic correction fails, please check the following.
 - Check that the media is not skewed
 -  ["Loading the Media"\(P. 62\)](#)
 - Check for ejection failures
 -  ["Test Printing"\(P. 87\)](#)
 -  ["DAS \(Automatic Correction Function\) Sensor Cleaning"\(P. 131\)](#)
-





- If automatic correction is unsuccessful, adjust manually.
 -  ["Feed Correction"\(P. 92\)](#)
 -  ["Correcting the Drop Position"\(P. 94\)](#)
-

2.7 Feed Correction

Changing the media may affect the feed amount due to various factors, including the weight and thickness of the media and whether the take-up unit is used. Correct the drop position to suit the type of media used. Image defects (e.g., dark or light streaks) will result if the feed is not properly corrected.

Check beforehand

- Is media loaded?  "Loading the Media"(P. 62)
- For roll media, is the rear roll media free of sagging?
- When using the take-up unit, is the media mounted on the paper core of the take-up unit?  "Loading the Roll Media"(P. 68)



- The ink used in the machine is warmed before printing. Printing and cleaning is disabled while the ink is being warmed.

● Pullback printing

[Feed Comp.(pull-back)] adjustment must be performed before using pullback printing with roll media. The correction value will be applied when pullback printing is performed.



- For more information, refer to the "UJ330H Clear Ink Print Guide". <https://mimaki.com/download/software.html>

The adjustment method is the same as for [Feed Comp.].  "Feed Correction Procedure"(P. 92)

● Performing [[Feed Comp.(pull-back)]] causes the following actions:

- (1) Media forward/backward feeding starts.
 - The media will become slack.
- (2) A correction pattern is printed.

Feed Correction Procedure

Print a correction pattern, then enter the correction value. The value corrected here will also be updated on the Media Setting menu.



- When using the take-up unit, load media on the take-up unit before correcting.

1 On the LOCAL mode screen, select [ADJUST].

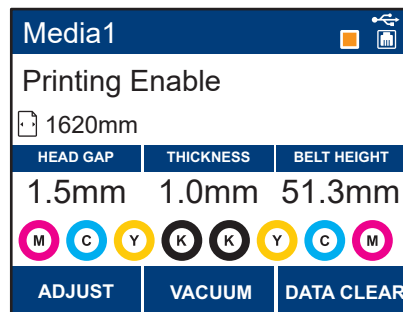

2 Select [Feed Comp.], then press the [ENTER] key.

- Correction pattern printing starts.



For pullback printing:

- Select [Setup] > [[Feed Comp.(pull-back)]].

3 Check the print results.

- A correction value input screen appears.
- Adjust the bands so that the region between them is evenly colored.

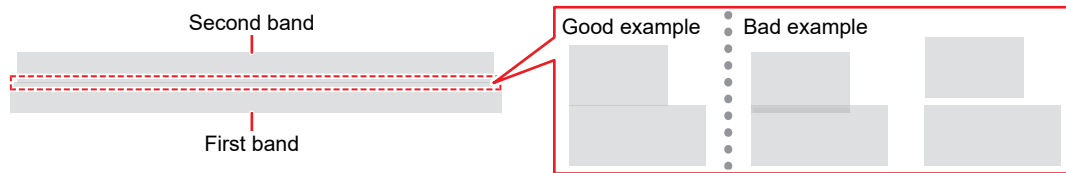

4 Enter the correction value, then press the [ENTER] key.

- "+" input: Increases the separation between bands.
- "-" input: Reduces the separation between bands.
- Increment the correction value by "60" to move the bands by approximately 0.1 mm.

5 Press the [ENTER] key.

- Print another correction pattern to check.



- Once adjustment is complete, the medium will be fed to the print origin. Sagging may occur in the rear roll medium. Rewind roll media by hand to eliminate any sagging.

Correcting the Media Feed During Printing

You can also correct the media feed amount in REMOTE mode or during printing.

1 Press [ADJUST] in REMOTE mode or during printing.



2 Enter the correction value, then press the [ENTER] key.

- Correction value: -9999 to 9999
- The value entered here will be updated immediately.

2.8 Correcting the Drop Position

Changing the media and print head height and temperature changes around the print head will also alter the drop positions. Correct the drop position to suit the type of media used. Image defects (e.g., overlaid lines or blurred images) will result if the drop position is not properly corrected.

Check beforehand

- Was the print head adjusted?  "Adjusting Print Head Height"(P. 60)
- Is media loaded?  "Loading the Media"(P. 62)



- Load media at least 500 mm wide. You cannot print the entire pattern if media less than 500 mm wide is used.



- The following screen display indicates that the print head is being warmed. Printing starts once the proper temperature is reached.

Waiting Temp stabilize
0:01:20

- Printing can be started without waiting for the print head to reach the proper temperature by pressing the [ENTER] key while the screen is displayed, but dot printing may be offset.

Drop Position Correction Procedure

Print a correction pattern, then enter the correction value. The value corrected here will also be updated on the Media Setting menu. This must be adjusted for each print resolution.

- 1 On the LOCAL mode screen, select [ADJUST].

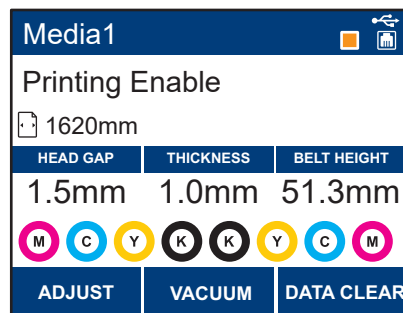

- 2 Select [Drop.PosCorrect], then press the [ENTER] key.

- 3 Select the resolution, then press the [ENTER] key.

- Select the resolution to be adjusted. When "All" is selected, correction patterns for all resolutions will be printed. Media Setting Menu



- The indicated resolutions are those in the scan direction.

4 Check the print results.

- A correction value input screen appears.
- Enter the position where the two upper and lower lines coincide.

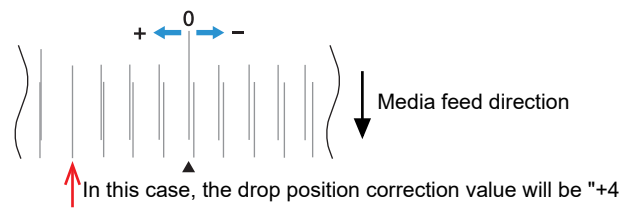

5 Enter the correction value, then press the [ENTER] key.

- Correction value: -40 to 40



- If the lines do not coincide when the correction value is within the range -40 to 40, the print head height may have been improperly adjusted. Adjust the print head height. ["Adjusting Print Head Height"\(P. 60\)](#)

6 Enter the correction value in the same way for pattern 2 and subsequent patterns.

2.9 Preparing RIP data

The explanation here applies to MIMAKI RIP software (RasterLink).



- Prepare suitable image data for printing.

1 Launch RasterLink.

- Click the icon on the PC desktop.



2 Select the image data to print.

- (1) Select [File] > [Open].
- (2) Select the desired image data, then click [Open].
 - If multiple printers are registered, select UJ330H-160 in "Printer Name".

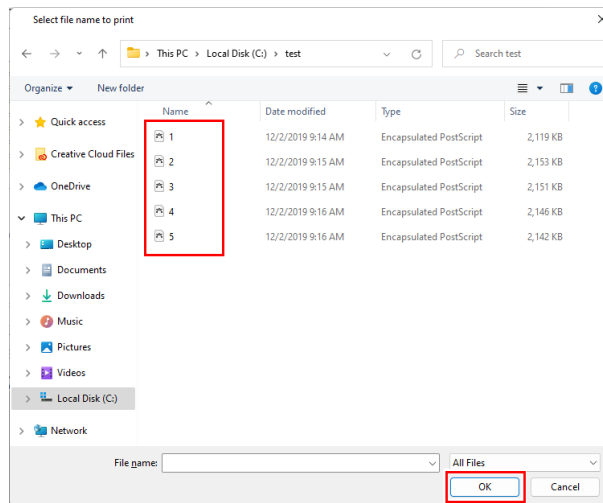

3 Select the image data imported.

- The image data is added in the tab for UJ330H-160 selected in "Printer Name".

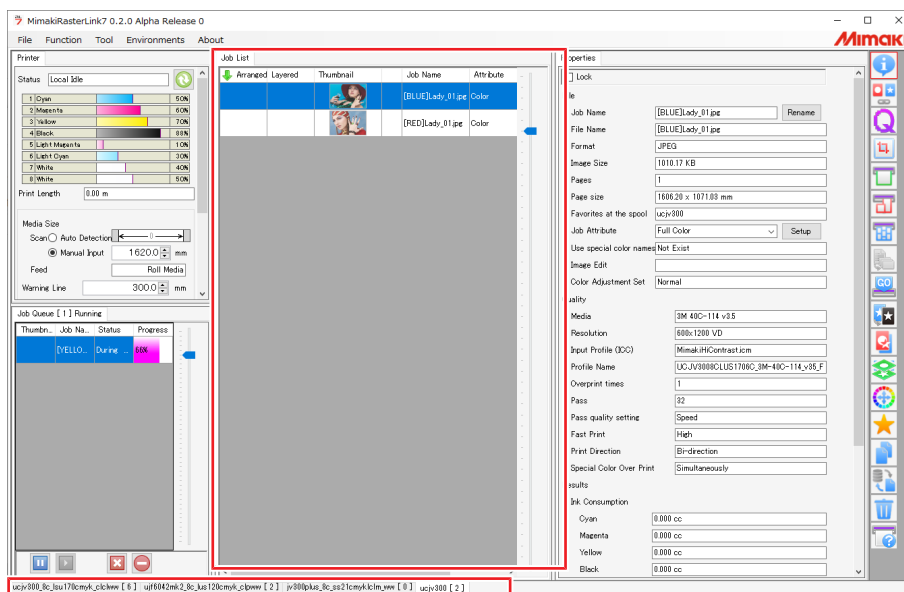

4 Edit the image.

- Specify the following settings by clicking the function icons shown on the right-hand side of the screen:

When using roll media:

 (General Print): Specifies settings like enlargement/reduction and rotation.

When using rigid media:

 (Rigid Media Layout Printing): Adjust various settings such as scaling, reduction, and rotation to match the layout of the rigid media set in the printer.

Common to both roll and rigid media:

 (Quality): Selects a color profile for the media and ink set loaded in this machine.



- For more information, refer to the RasterLink reference guide. <https://mimaki.com/download/software.html>
-

5 Print image data.

-  "Starting Printing"(P. 99)



- (1) Click  (Execution) from the function icons on the right-hand side of the screen.
 - (2) Select "Immediate Print" or "RIP and Print", then click [Start].
-



- Media width must be reacquired after replacing media.
 - (1) Select the tab for UJ330H-160 in the main window.
 - (2) Click  (Update the printer status) in the Printer tab.
-

2.10 Printing

Check beforehand

- Has the print head height been correctly set? ([Menu] > [Media Setting] > [Media Information])  "Adjusting Print Head Height"(P. 60)
- Has the media been loaded? ([Menu] > [Media Setting] > [Media Information])  "Loading the Media"(P. 62)
- For roll media, is the rear roll media free of sagging?
- When using the take-up unit, was the media mounted on the paper core of the take-up unit?  "Loading the Roll Media"(P. 68)

Changing the origin

The print start position can be altered. Use the LED pointer to set the origin.

1 On the LOCAL mode screen, press .

- The Origin Setup screen appears.

2 Press to move the origin to the desired position.

- The carriage moves left and right and feeds the medium.



- Pressing the [FUNC2] key lowers Z by a preset amount making the LED pointer easier to see.
Pressing the [FUNC2] key again raises Z to its original position.

3 Press the [ENTER] key.

- The origin is updated.

Starting Printing

1 Send the RIP data from the PC.

-  "Preparing RIP data"(P. 96)



- If an error message appears, check the appropriate action by referring to the error number. Error messages

2 Start printing.

- Printing starts once RIP data is received.

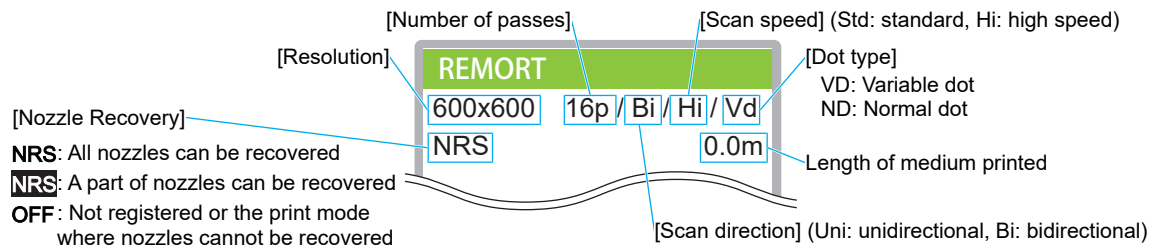

- Print speeds may differ for the same image data, depending on the width of the medium loaded, print origin position, and resolution.
- If an error occurs, the machine switches to LOCAL mode once printing is completed. Further printing is not possible.
- The ink used in this machine is warmed before printing. Printing is disabled while the ink is warmed.
- When printing on rigid media, the suction fan will automatically switch to "High" toward the end of the print job. This operation is an intended specification designed to maintain feeding accuracy. Thank you for your understanding.

Pausing Printing

1 Press [LOCAL] while printing is in progress.

- Printing is paused.
- If data is being sent from a PC, data transmission is paused at the PC.

2 Press [REMOTE].

- Printing resumes.



- No other functions can be used when printing is paused.

Stopping Printing (Data Clear)

- 1 On the LOCAL mode screen, select [DATA CLEAR].

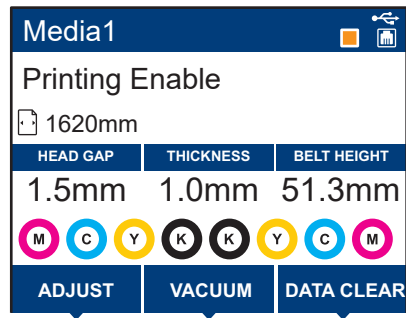

- 2 Press the [ENTER] key to clear the received data.
 - The receive buffer is cleared.

Eject the rigid media

- (Important!)** • When using this feature, be sure to install the Roller Table Assy (optional). If the Roller Table Assy is not in place, the media may fall out the front of the machine.

- 1 Select [MEDIA] from the Local screen.

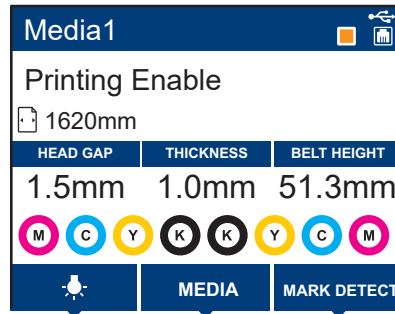

- 2 Select [Rigid Media Eject].
- 3 Press the [ENTER] key on the Rigid Media Ejection screen to execute the operation.

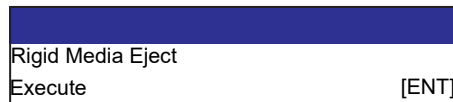

- This feature is designed to eject rigid media. Therefore, this feature cannot be used when roll media is loaded or when rigid media is not loaded.



- 4 Once the media has been ejected, remove the rigid media toward the Roller Table Assy.
- 5 Once you have finished removing the rigid media, press the [ENTER] key.

Pause Rigid Media Ejection

- 1 Press the [END] key while the rigid media is being executed.
 - Rigid media ejection will be interrupted.
- 2 Press the [ENTER] key on the Rigid Media Ejection screen to execute the operation.
 - Rigid media ejection will resume.

2.11 Pullback printing



- For more information, refer to the "UJ330H Clear Ink Print Guide". <https://mimaki.com/download/software.html>

Perform the following beforehand

- [Feed Comp.(pull-back)] adjustment must be performed before using pullback printing with roll media. "2.7 Feed Correction"(P. 92)
- Perform the [Pull-back Origin Offset] adjustment. "When using pullback printing for register marks"(P. 102)

The pullback printing function of this machine operates as shown in the table below.

Media Type	With register marks	No register marks
Roll	Recommended	Not recommended (Print misalignment may occur)
Rigid Media	Not supported	Supported



When performing pullback printing with rigid media, please observe the following precautions:

- Do not change the print origin.
Changing the print origin may cause pullback printing to malfunction.
- Set the media detection setting to AUTO.
After pullback printing is completed, media detection will be performed automatically. Therefore, if the media detection setting is set to MANUAL, pullback printing cannot be executed.

When using pullback printing for register marks

Adjust using the following procedure.



- These adjustments will not be applied to pull-back printing without register marks.

1 On the LOCAL mode screen, select [ADJUST].

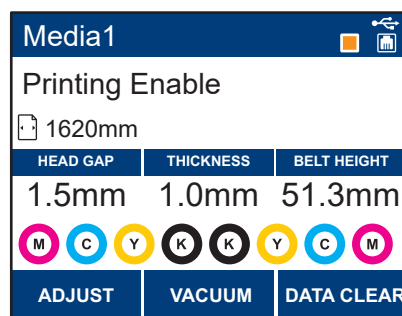

2 Select [Pull-back Origin Offset], then press the [ENTER] key.

3 Select the resolution to be used for the print in the Y direction, then press the [ENTER] key.

- Y resolution: 600Std, 600Hi, 1200Std, 1200Hi
- Correction pattern printing starts.

4 Check the print results.

- A correction value input screen appears.

5 Enter the correction value, then press the [ENTER] key.

- Align the second layer pattern with the first layer pattern,
- First layer (white), second layer (magenta)

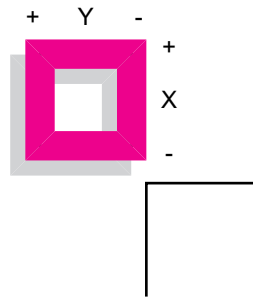

- If the second layer pattern overlaps the register mark: Enter a positive value.
- If the second layer pattern is away from the register mark: Enter a negative value.

6 Press the [ENTER] key.

- Print another correction pattern to check.

If Mark Detection Fails

Register mark detection is performed once the first layer has been printed. If mark detection fails, perform the following.



If mark detection fails when using clear media

- Change the register marks to the solided register marks. Specify "White" as the fill color.

1 On the LOCAL mode screen, select [MARK DETCT], then press the [ENTER] key.

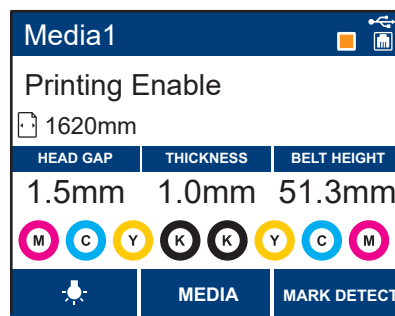

2 Press the \downarrow \uparrow \leftarrow \rightarrow keys to move the DAS sensor light source to the center of the register mark printed on left side rear edge.

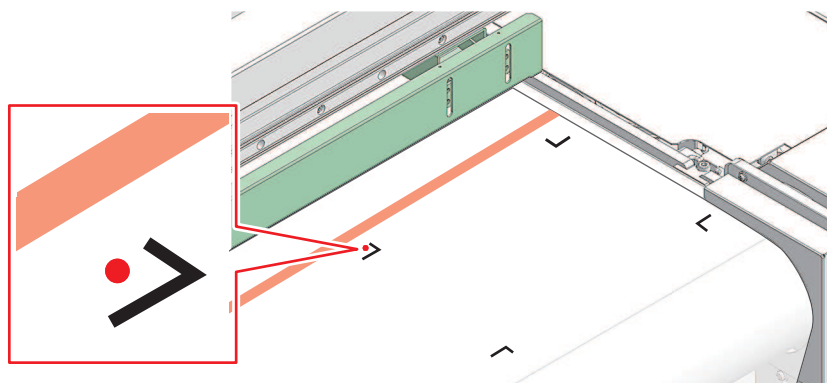

3 Press the [ENTER] key.

- Register mark detection starts.
- If mark detection is successful, move to the origin for the second layer printing start position.

2.12 About 2.5D printing



- For more information, refer to the "2.5D Texture Maker Guide". <https://mimaki.com/download/software.html>

Perform the following beforehand

- When performing 2.5D printing, adjust the head height to 2.1mm or more to prevent collision between the print media and the print head. ["Adjusting Print Head Height"\(P. 60\)](#)

● Ink type corresponding to 2.5D printing

Ink type	Ink set	Special Colorset
LUS-170	CMYK	CICIWW
LUS-175	CMYK	CICIWW

● Special colorsets and available modes

Color	Special Colorset	Standard mode	High speed mode
4 Color+SP	CICIWW	OK	N/A

Important! Media winding

- Note that meandering is more likely to occur with longer media taken up after 2.5D printing.

Chapter 3 Setup



This chapter

This chapter describes the [MENU] functions.

Media Setting Menu	108	Function Setting Menu	118
Maintenance Menu	112	Environment Setting Menu	120
Registering Nozzle Recovery	114	Machine Status Menu	122
Nozzle Check	116		
Cap Suction Check	116		

3.1 Media Setting Menu

When you use the machine for the first time, the Select Use Media screen is displayed.  ["Registering the Media"\(P. 83\)](#) The media Information and correction value can be saved in advance for specific media.





- To set print conditions for a single use, select "Temporary". The conditions set in "Temporary" are cleared when the machine is restarted.













The user can select to prioritize the settings on the machine or the settings on the PC. Setting individual menus to "Host" prioritizes PC settings. To prioritize settings for this machine, select a setting other than "Host".



- For more information on how to specify RIP software, refer to the RIP software operating manual.

● Menu List

Item	Setting		Details
	*1	*2	
Feed Comp.	-9999 to <u>0</u> to 9999	-	Corrects the media feed amount. Print a pattern and enter the correction amount.  "Feed Correction"(P. 92)
Drop.PosCorrect	-	-	Corrects the drop position for bi-directional printing.  "Correcting the Drop Position"(P. 94)
(Resolution)	*	-	Select the resolution to be corrected. When "All" is selected, correction patterns will be printed for all resolutions. * The available resolutions vary according to the model.
(Correction Value)	-40.0 to <u>0</u> to 40.0	-	Check the pattern and enter correction values.
Auto-correction	-	-	The auto-correction function (DAS: Dot Adjustment System) detects a correction pattern with the sensor and automatically corrects the drop position.
All	-	-	When "All" is selected, "Feed Comp." and "Drop.PosCorrect" are corrected. <ul style="list-style-type: none"> • Check to confirm that the media does not lift up. • Load clean media. • Media such as synthetic paper, tarpaulin, or cloth media may not be detected. • Do not send RIP data from the PC during pattern printing. • If automatic correction is unsuccessful, correct the position manually. [MENU] > [Media Setting] > [Feed Comp.] or [Drop.PosCorrect]
Feed Comp.	-	-	
Drop.PosCorrect	-	-	
(Resolution)	*	-	Select the resolution to be corrected. When "All" is selected, correction patterns will be printed for all resolutions, and the drop position is corrected automatically. * The available resolutions vary according to the model.
Feed Comp.(pull-back)	-9999 to <u>0</u> to 9999	-	This adjustment must be performed before using pullback printing with roll media. Corrects the media feed amount specifically for the pullback printing function. <ul style="list-style-type: none"> • Print a pattern and enter the correction amount.  "Feed Correction"(P. 92)

Item	Setting		Details																
	*1	*2																	
			<ul style="list-style-type: none"> This item is displayed in cases other than when "Rigid" or "Clear Rigid" is selected for media type. 																
Head height	-	-	Set the head gap and media thickness.  "Registering the Media"(P. 83)																
<table border="1"> <tr> <td>Head gap</td> <td>1.5 to 3.0 mm</td> <td>-</td> <td>Set the head gap.</td> </tr> <tr> <td>Media thickness</td> <td>0.0 to 50.8 mm</td> <td>-</td> <td>Set the media thickness. Check (measure) the media thickness, then enter the value.</td> </tr> <tr> <td>Belt height</td> <td>0.0 to 52.3 mm</td> <td>-</td> <td>Set the media feeding belt height. Changing the belt height also changes the media thickness.</td> </tr> <tr> <td>Thickness correction</td> <td>-</td> <td>-</td> <td>Measure the thickness of the currently loaded media, then correct the media thickness setting. <ul style="list-style-type: none"> Errors of approximately ± 0.1 mm may occur. </td> </tr> </table>	Head gap	1.5 to 3.0 mm	-	Set the head gap.	Media thickness	0.0 to 50.8 mm	-	Set the media thickness. Check (measure) the media thickness, then enter the value.	Belt height	0.0 to 52.3 mm	-	Set the media feeding belt height. Changing the belt height also changes the media thickness.	Thickness correction	-	-	Measure the thickness of the currently loaded media, then correct the media thickness setting. <ul style="list-style-type: none"> Errors of approximately ± 0.1 mm may occur. 			
	Head gap	1.5 to 3.0 mm	-	Set the head gap.															
	Media thickness	0.0 to 50.8 mm	-	Set the media thickness. Check (measure) the media thickness, then enter the value.															
	Belt height	0.0 to 52.3 mm	-	Set the media feeding belt height. Changing the belt height also changes the media thickness.															
Thickness correction	-	-	Measure the thickness of the currently loaded media, then correct the media thickness setting. <ul style="list-style-type: none"> Errors of approximately ± 0.1 mm may occur. 																
UV mode	ON/OFF/NoPrint	ON	Sets whether to turn on or off the UV-LED lamp. <ul style="list-style-type: none"> ON: Turns on the lamp. OFF: Does not turn on the lamp. NoPrint: Turns on the lamp without printing. (Not used under ordinary conditions) 																
UV AdjVal	-50 to 0 to +50 %	-	The preset UV-LED lamp brightness can be altered. Check the performance (e.g. stickiness and odor) after printing. <ul style="list-style-type: none"> Minus direction: Reduces hardness. Plus direction: Increases hardness. 																
MAPS*	-	-	MAPS: Mimaki Advanced Pass System This function disperses the boundaries between passes to make feed streaks between passes less visible. Altering MAPS may alter the color. This function may be less effective with certain types of images. * The MAPS version will vary according to the model.																
<table border="1"> <tr> <td>MAPS*</td> <td>AUTO/MANUAL</td> <td>-</td> <td>This should normally be set to "AUTO". When set to "MANUAL", the following items are displayed:</td> </tr> <tr> <td>Speed</td> <td>50 to 100 %</td> <td>-</td> <td>Reducing speed will make streaks less visible. However, printing will be slower.</td> </tr> <tr> <td>Smoothing Level (Color)</td> <td rowspan="2">0 to 100 %</td> <td rowspan="2">-</td> <td rowspan="2">Increasing smoothing makes streaks less visible. Make separate settings for color and spot color (white).</td> </tr> <tr> <td>Smoothing Level (Spot)</td> </tr> </table>	MAPS*	AUTO/MANUAL	-	This should normally be set to "AUTO". When set to "MANUAL", the following items are displayed:	Speed	50 to 100 %	-	Reducing speed will make streaks less visible. However, printing will be slower.	Smoothing Level (Color)	0 to 100 %	-	Increasing smoothing makes streaks less visible. Make separate settings for color and spot color (white).	Smoothing Level (Spot)						
	MAPS*	AUTO/MANUAL	-	This should normally be set to "AUTO". When set to "MANUAL", the following items are displayed:															
	Speed	50 to 100 %	-	Reducing speed will make streaks less visible. However, printing will be slower.															
	Smoothing Level (Color)	0 to 100 %	-	Increasing smoothing makes streaks less visible. Make separate settings for color and spot color (white).															
Smoothing Level (Spot)																			
Media Information	-	-	Enter the media information.																
<table border="1"> <tr> <td>Media Type</td> <td>-</td> <td>-</td> <td>Select the media type to be used. The available media types vary depending on the model.</td> </tr> <tr> <td>Media detect</td> <td>-</td> <td>-</td> <td>Set the media detection method.</td> </tr> <tr> <td>Detection Type</td> <td>AUTO/MANUAL</td> <td></td> <td> <ul style="list-style-type: none"> AUTO: The media width and front edge is automatically detected with the sensor. MANUAL:  Press  to set the media width manually. <ul style="list-style-type: none"> When using rigid media, press  or  to set the media front edge manually. When the media cannot be detected correctly, set the media detection method to "MANUAL". </td> </tr> </table>	Media Type	-	-	Select the media type to be used. The available media types vary depending on the model.	Media detect	-	-	Set the media detection method.	Detection Type	AUTO/MANUAL		<ul style="list-style-type: none"> AUTO: The media width and front edge is automatically detected with the sensor. MANUAL:  Press  to set the media width manually. <ul style="list-style-type: none"> When using rigid media, press  or  to set the media front edge manually. When the media cannot be detected correctly, set the media detection method to "MANUAL". 							
	Media Type	-	-	Select the media type to be used. The available media types vary depending on the model.															
	Media detect	-	-	Set the media detection method.															
Detection Type	AUTO/MANUAL		<ul style="list-style-type: none"> AUTO: The media width and front edge is automatically detected with the sensor. MANUAL:  Press  to set the media width manually. <ul style="list-style-type: none"> When using rigid media, press  or  to set the media front edge manually. When the media cannot be detected correctly, set the media detection method to "MANUAL". 																

Item	Setting		Details
	*1	*2	
Media Remain	-	-	The remaining roll media amount can be displayed and printed out in REMOTE mode. <ul style="list-style-type: none"> This item is displayed in cases other than when "Rigid" or "Clear Rigid" is selected for media type.
Media Remain Manage	ON/OFF	-	<ul style="list-style-type: none"> ON: An input screen appears once the media width is detected. ▲ Press ▼ to set the media length. Press the [FUNC3] key on the "Origin Setup" screen to print the date and remaining media amount. OFF: The remaining media amount is not displayed.
Length	0 to 500 m	-	Enter the roll media length.
Media length	280 to 3100 mm		Enter the rigid media length. <ul style="list-style-type: none"> This item is displayed when "Rigid" or "Clear Rigid" is selected for media type.
Number of media sheets	1 to 7		Enter the number of media sheets when rigid media sheets are loaded side by side. <ul style="list-style-type: none"> This item is displayed when "Rigid" or "Clear Rigid" is selected for media type.
Detail Setting	-	-	This is used to set various functions.
Vacuum Fan	Host/Weak/Standard/Strong	Standard	Sets the force with which the medium is held down. <ul style="list-style-type: none"> If the rigid media is warped or problems occur with feeding accuracy, set [High].
Feed Speed	Host/10 to 100 to 200 %	100	Sets the media feed speed. <ul style="list-style-type: none"> Depending on print conditions, the speed may not vary for certain settings. Setting to 100 % or more reduces the time required to complete printing but may affect print quality due to insufficient drying time.
Rear clamp roller	OFF/ON	100	Sets whether the rear clamp roller is used. <ul style="list-style-type: none"> This item is displayed when "Rigid" or "Clear Rigid" is selected for media type. Do not use the rear clamp rollers when printing on roll media.
Work Change	-	-	Set whether to return to the Local screen or remain on the Remote screen once online printing is complete when using rigid media. <ul style="list-style-type: none"> This item is displayed when "Rigid" or "Clear Rigid" is selected for media type.
Setup	ON/OFF	-	Enable or disable the work change function.
Auto Media Eject	ON/ OFF	-	Set whether to automatically eject the media when online drawing is complete.  "Eject the rigid media"(P. 101) <ul style="list-style-type: none"> This item is displayed when the "Work Change" setting is turned on.
Auto Vacuum Fan Stop	ON/ OFF	-	Set whether to automatically stop the snap fan when you return to the local screen after finishing online drafting. <ul style="list-style-type: none"> This item is displayed in the following cases. <ul style="list-style-type: none"> Work Change Setting: ON Automatic Media Ejection Setting: OFF

Item	Setting		Details
	*1	*2	
Media Name Change	-	-	You can change the name of a setting type. The name can include alphanumeric characters or symbols.
Delete MediaInfo	-	-	Delete the set media information.





*1. The default settings are shown underlined.



*2. Settings applied if no settings can be made in the RIP software (host) or if this machine is prioritized.

3.2 Maintenance Menu

This menu is used for maintenance actions. It also lets the user perform nozzle recovery if nozzle clogging persists even after cleaning and nozzle washing.

● Menu List

Item	Setting ^{*1}	Details
Station Maint.	-	This moves the carriage to allow station and print head maintenance.
Carriage Out	-	
Move To Platen Right End	-	Cleans around the station, including the cap, wiper, and NCU. Cap Rubber Cleaning NCU Cleaning
Move To Maint. Space	-	Cleans around the print head. Carriage Underside Cleaning Media Sensor Cleaning DAS (Automatic Correction Function) Sensor Cleaning
Nozzle Wash	1 to 99 min	Washes the print head nozzle surface with maintenance liquid to resolve ejection failures (e.g., nozzle clogging or deflection). Print Head Nozzle Washing
Pump Tube Cleaning	-	Washes the suction pump tube (below the cap). Ink Discharge Channel Cleaning
Custody Wash	1 to 99 min	Perform this step if the machine will not be used for extended periods. The function washes nozzles and drainage channels to maintain the machine in optimal condition. When this Printer is Left Unused for a Long Time
Replace Wiper	-	Use this function when replacing the cloth wiper. Replacing the cloth wiper resets the cloth wiper used length stored in the machine. Cloth Wiper Replacement
Cap Replacement	-	Use this function when replacing the cap. Replacing the cap resets the cap usage time stored in the machine. Cap Replacement
Test Printing	-	Print a test pattern to confirm that the ink prints correctly. Perform head cleaning if you observe any ejection failures (e.g., nozzle clogging or deflection).  "Test Printing"(P. 87)
Cleaning	-	Several head cleaning methods are available. Choose the head cleaning method based on test print results.  "Head Cleaning"(P. 89)
Nozzle Recovery	-	Allows other nozzles to be used for printing if maintenance actions like nozzle washing fail to resolve ejection failures (e.g., nozzle clogging or deflection).
Print	-	Prints a pattern to check nozzle condition and register the nozzle.  "Registering Nozzle Recovery"(P. 114)
Entry	-	Registers the nozzle without printing a pattern.
Reset	-	Initializes the details set.
Test Printing	ON/OFF	Sets whether to perform nozzle recovery before test printing.
Nozzle Check	-	 "Nozzle Check"(P. 116)
Printing Check	ON/OFF	Performs nozzle clogging detection before printing starts.
Check Interval	-	Sets the nozzle clogging detection timing.

Item		Setting *1	Details
	Length	0.1 to <u>30.0</u> to 100.0 m	Performs nozzle clogging detection after the length set is reached and before the next print starts.
	File	1 to <u>30</u> to 1,000 files	Performs nozzle clogging detection after the preset number of files has been printed and before the next print starts.
	Continuation Print	<u>Stop/</u> Continuous	Select whether to stop or continue printing if "Nozzle clogging" is detected.
	Action	Off/1 to <u>10</u> to 100	Performs nozzle recovery (cleaning followed by nozzle checking) if "nozzle clogging" is detected.
	Cleaning	<u>Soft/Normal/</u> Hard	Sets the cleaning type.
	Retry Count	<u>0</u> to 3 times	Performs nozzle recovery (cleaning followed by nozzle checking) for the specified number of times.
	Auto Nozzle Recovery	ON/ <u>OFF</u>	Performs nozzle recovery automatically if "nozzle clogging" is detected. See below if you wish to perform nozzle recovery manually.  "Registering Nozzle Recovery"(P. 114)
Judgment Condition *2	OFF / <u>1</u> to 64 nozzles	Set the number of nozzles to be detected as clogged before "nozzle clogging" is detected. Up to 16 nozzles per row can be set. The next print will not start if "nozzle clogging" is detected during continuous printing.	
Auto Maint.	-	Sets various maintenance actions to be performed automatically. Set the interval between individual maintenance actions. <ul style="list-style-type: none"> If the warning message "Replace Wasteinktank" appears, the automatic maintenance function is disabled.  "Waste Ink Tank Replacement"(P. 150) 	
	Refresh	0.5 to <u>4.0</u> h	Sets the refresh interval (when a small amount of ink is ejected from the print head nozzles).
	Cleaning Interval	1 to <u>24</u> h	Sets print head cleaning intervals. This will help prevent nozzle clogging.
	Type	<u>Soft/Normal/</u> Hard	Sets the cleaning type for head cleaning.
Print Maint.	-	Sets the maintenance to be performed automatically midway during printing.	
	Auto Cleaning	-	Sets the conditions to perform head cleaning after the preset number of files are printed.
	Setup	File/Length/ Time/ <u>OFF</u>	Sets the conditions to perform head cleaning. <ul style="list-style-type: none"> Default value when using ELS-170/175 ink: Time
	Interval	-	Sets head cleaning intervals.
	(File)	1 to 1,000	Cleaning starts when the set number of files is exceeded.
	(Length)	0.1 to 100.0 m	Cleaning starts when the set print length is exceeded.
	(Time)	0.5 to 30.0 h	Cleaning starts when the set print time is exceeded. <ul style="list-style-type: none"> When using ELS-170/175 ink, default value: 4.0h
	Type	<u>Soft/Normal/</u> Hard	Sets the cleaning type for head cleaning.
Cleaning Check	ON/ <u>OFF</u>	Sets whether nozzle checking is performed after head cleaning is completed.	

Item	Setting ^{*1}	Details
Interval Wiping	<u>OFF</u> /3 to 255 min	Wiping starts when the set print time is exceeded.
Waste Ink Tank	-	Resets or corrects the waste ink tank usage count. "Waste Ink Tank Replacement"(P. 150)
Reset Waste Ink Volume	-	Resets the waste ink tank usage count. "Replacing the Waste Ink Tank"(P. 150)
Adjust Waste Ink Volume	-	Corrects the waste ink tank usage count. "When "Check Waste Ink Tank" message appears"(P. 150)
Air PG	-	Expels any air in the ink paths. <ul style="list-style-type: none"> Use this in case of considerable nozzle clogging with white ink (dropouts). "There is considerable nozzle clogging with white ink"(P. 164)
Ink Supply Maint.	-	<ul style="list-style-type: none"> Use this in case of ink supply errors in the white ink path.
White Maintenance	-	Prevents ink sedimentation inside the ink routes. <ul style="list-style-type: none"> Use this when uneven color occurs for the white ink.
Meander Recovery Action	-	Eliminates media feeding belt meandering. <ul style="list-style-type: none"> Use this when a Meander Limit Response error occurs.
Cap Suction Check	-	You can check to see if the cap is working properly. <ul style="list-style-type: none"> Execute this procedure if cleaning does not resolve ejection failures (such as nozzle clogging or nozzle deflection). "Cap Suction Check"(P. 116)
FillUp Individ. Ink	-	The selected ink path will be filled. <ul style="list-style-type: none"> Execute this procedure when a specific ink has caused a large number of nozzles to experience nozzle clogging (dropouts). "A large amount of a specific ink caused nozzle clogging"(P. 165)

*1. The default settings are shown underlined.

Registering Nozzle Recovery

Allows other nozzles to be used for printing if maintenance actions like nozzle washing fail to resolve ejection failures (e.g., nozzle clogging or deflection).



- Nozzle recovery can be specified for up to 10 nozzles per row. The time taken for printing remains unchanged even when nozzle recovery is set.



- Load media at least 500 mm wide. You cannot print the entire pattern if media less than 500 mm wide is used.

- 1 Position the media.**
- 2 On the LOCAL mode screen, select [MENU] > [Maintenance], then press the [ENTER] key.**
 - The Maintenance menu is displayed.

3 Select [Nozzle Recovery] > [Print], then press the [ENTER] key.

- Print a nozzle recovery pattern.
- The Select Entry Nozzle screen appears once printing is complete.

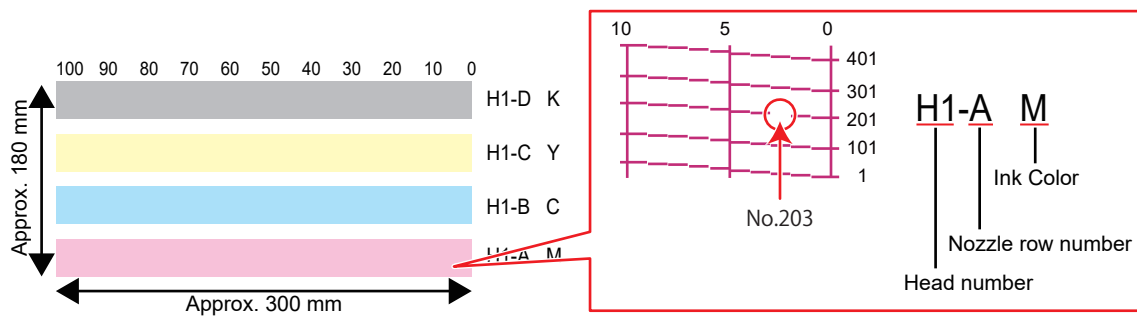

4 Select the "head number and nozzle row" for nozzle recovery, then press the [ENTER] key.

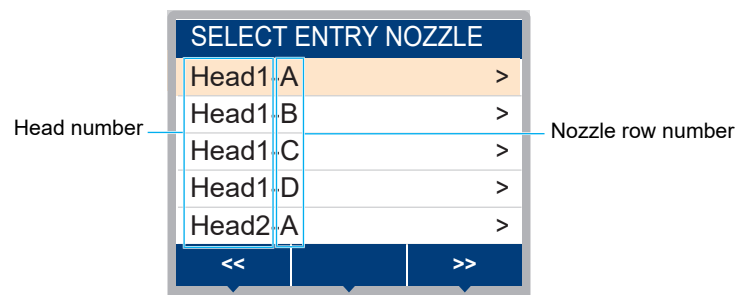

5 Enter the "nozzle number" for nozzle recovery, then press the [ENTER] key.

- Select the entry number before entering the nozzle number.
- Nozzle recovery is set.

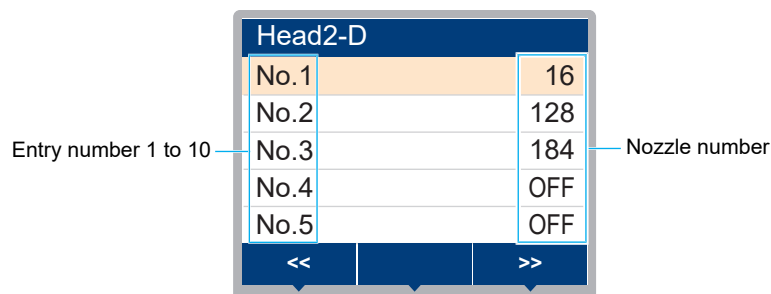

6 Press the [ENTER] key once entry is complete.



- Select [Maintenance] > [Nozzle Recovery] > [Test Print], then select "ON" to perform nozzle recovery and test printing. Test Printing

Nozzle Check

This is used to check for nozzle clogging before printing starts. Sets whether to perform maintenance functions automatically if nozzle clogging is detected.

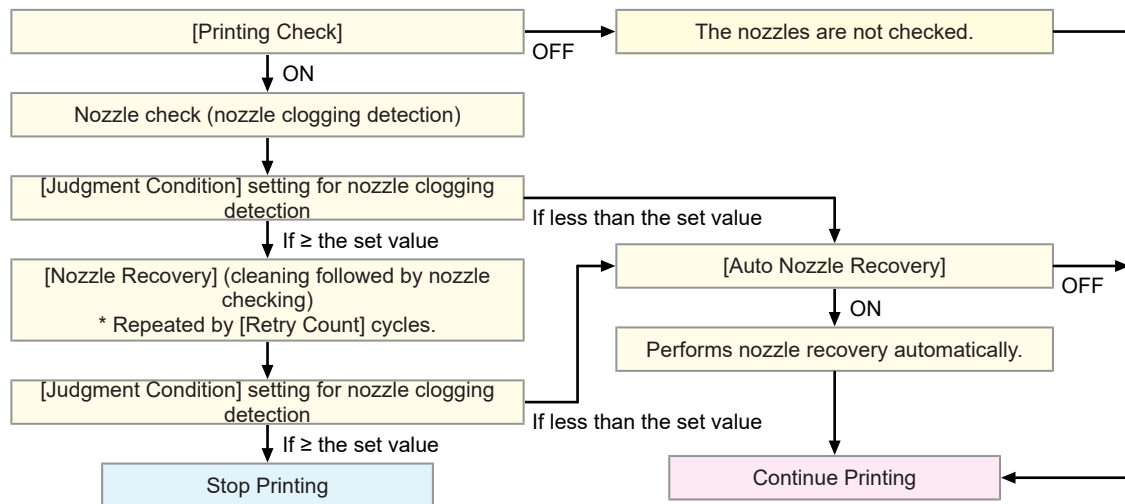

Cap Suction Check

Execute this procedure if ejection failures (such as nozzle clogging or nozzle deflection) persist even after cleaning. Check to see if ink is being drawn up through the cap.

- 1** On the **LOCAL** mode screen, select **[MENU] > [Maintenance]**, then press the **[ENTER]** key.
 - The Maintenance menu is displayed.
- 2** Select **[Cap Suction Check]** and press the **[ENTER]** key.
- 3** Press the **[ENTER]** key.
 - The suction operation is performed automatically.
 - After the suction cycle is complete, the carriage moves onto the platen.
- 4** Open the maintenance cover on the right side and press the **[ENTER]** key.

5 Check each cap to see if it contains ink.

- If the ink is being drawn up properly, it will collect in the cap. It tends to accumulate along the edges.

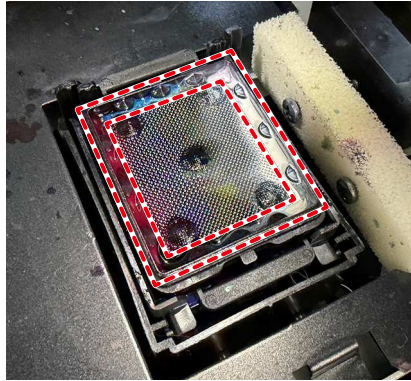

- If there is no ink in the cap, it is not drawing ink properly. Please replace it with a new cap.  "[Cap Replacement](#)"(P. 146)

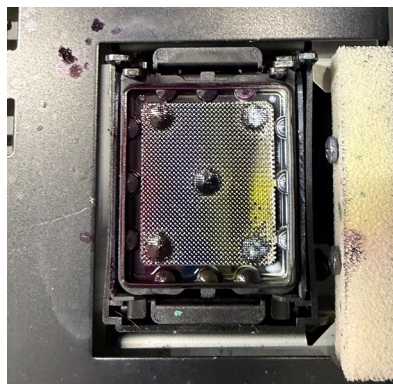

6 Select the cap that contains ink, and press the [ENTER] key.

- Please check the checkbox.

Cap Suction Check	
<input checked="" type="checkbox"/>	Cap 1 (left)
<input checked="" type="checkbox"/>	Cap 2 (right)
Select the cap that contains ink.	
<input type="button" value="✓"/>	



7 Close the maintenance cover, then press the [ENTER] key.

- Perform head cleaning on the cap you selected in Step 6.

3.3 Function Setting Menu

This is used to set various operations to ensure optimal machine performance.

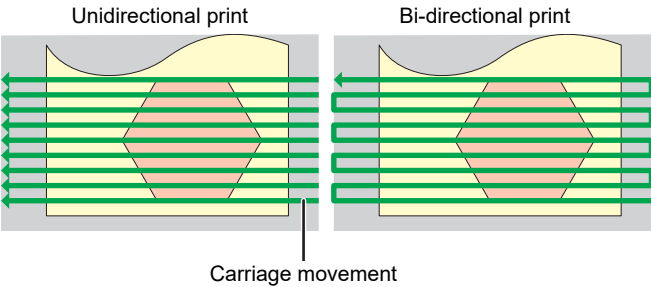
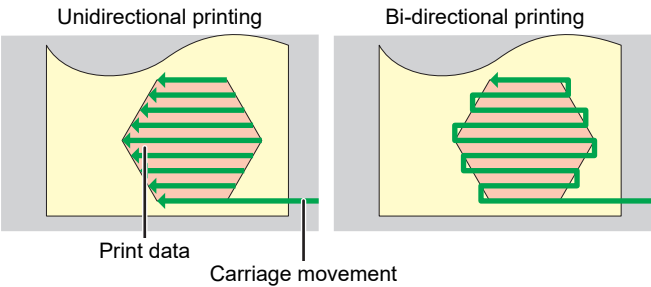
● Menu List

Item	Setting *1	Details
Logical Seek	<u>Host</u> /OFF/ON	<p>Sets the range of carriage movement.</p> <ul style="list-style-type: none"> OFF: Machine size area  <p>Carriage movement</p> <ul style="list-style-type: none"> ON: Print data area  <p>Print data Carriage movement</p>
Take-up Unit	-	Sets the take-up unit operation.
Take-up Unit	<u>ON</u> /OFF	Set to "OFF" if the take-up unit is not used.
Take-up SW	<u>Continuous</u> / Temporary	<p>Sets the function performed by the ON/OFF button on the take-up unit.  "Take-up unit"(P. 64)</p> <ul style="list-style-type: none"> Continuous: Press the button to start/stop the take-up unit. Temporary: The take-up unit operates only while the button is pressed. The unit stops when the button is released.
Print Take-up	Intermittent / <u>Continuous</u>	<p>Sets the take-up unit operation during printing.</p> <ul style="list-style-type: none"> Intermittent: Switches automatically between on and off. Continuous: Operates continuously. <p>If you are using slippery media or setting the take-up unit torque to "Medium" or higher, change the setting to "Intermittent."</p>
Power Setting	-	Sets the times to turn the power on and off automatically.
Auto Power-off	5 to <u>15</u> to 60 min	Sets the time until the power is automatically turned off.
Auto Power-on	-	Sets the time to automatically turn on the power.
Setup	<u>ON</u> /OFF	Sets whether to turn on or off the power.
Time	<u>0:00</u> to 23:59	Sets the time to turn on the power.
Day	Monday to Sunday	Sets whether to turn on or off the power on each day of the week.
Nozzle Check	<u>ON</u> /OFF	Automatically executes the nozzle check function when the machine is started with auto power-on. Performs nozzle recovery (cleaning followed by nozzle checking) if "nozzle clogging" is detected.

Item		Setting *1	Details
	Cleaning	<u>Soft</u> /Normal/ Hard	Sets the cleaning type.
	Retry Count	<u>0</u> to 3 times	Performs nozzle recovery (cleaning followed by nozzle checking) for the specified number of times.
WhiteSpace Setting		-	Sets the offset value from the media left and right standard margins (15 mm).
	Margin	-	<ul style="list-style-type: none"> The Mimaki RIP software (RasterLink) does not allow the user to specify margins. If the machine is set to "Host", the offset value will be "0 mm" for the left and right margins.
	Margin/Left	<u>Host</u> /-10 to 85 mm	
	Margin/Right		
	Space Btwn PP.	<u>None</u> /10 to 500 mm	<p>The space between prints can be eliminated for continuous printing.</p> <ul style="list-style-type: none"> Reducing the space length may cause media sagging, resulting in discrepancies in the distance the media is fed. Depending on the data size and number of passes in the feed direction, the margins may be wider than the set value.
	Space Feed Mode	<u>Intermittent</u> / Continuous	<p>Alters the feed method for blank space included in the image data.</p> <ul style="list-style-type: none"> Intermittent: Uses intermittent feeding based on the timing of a fraction of the pass. Continuous: Feeds forward by skipping blank parts.
View Feed		<u>ON</u> /OFF	Sets whether or not to feed the media forward to view the print results—for example, during test printing.
Illumination		-	Turns the light inside the printer on and off.
	LightingUp Type	<u>Auto</u> /Manual	Sets whether to turn the light on or off during printing and when the cover is opened.
	LightingUp Extention	None/1 to <u>5</u> to 10 min	Displayed when LightingUp Type is set to Auto. Sets the time during which the light is turned on after printing.
	Start Up Lighting	<u>ON</u> /OFF	Sets whether to turn the light on or off when the power supply switch is turned on.
Auto Remote		<u>ON</u> /OFF	Sets whether to automatically switch to REMOTE mode and start printing if data is received locally.
Ionizer		<u>ON</u> /OFF	<p>Set when the ionizer (option) is used.  "Ionizer"(P. 186)</p> <p>The machine prints while the ionizer removes static electricity from media. The electrode probes are not on unless the machine is printing.</p>

*1. The default settings are shown underlined.

3.4 Environment Setting Menu

This is used to set various operations to ensure optimal machine performance.

● Menu List

Item	Setting *1	Details
LANGUAGE	<u>English</u> / Japanese / Chinese / Turkish / Portuguese / Spanish / Italian / Korean	Sets the display language.
Time Set	-20 to <u>0</u> to +4 h	Sets the current time and date. (With respect to JST) • This can be set within the range of -20 to +4 hours.
Key Buzzer	<u>ON</u> /OFF	Sets an audible tone when keys are pressed. • Audible signals indicating errors, warnings, and operation end cannot be muted, even if "OFF" is selected for this setting.
Unit Setting	-	Set the display units.
Temp.	<u>°C</u> /°F	Sets the display unit for temperature (Celsius/Fahrenheit).
Length	<u>mm</u> /inch	Sets the display units for length and area. • Some items are displayed in "mm" even if "inch" is selected.
Network	-	Sets the network address. The machine must be restarted to enable this setting.
Check IP Address	-	Displays the machine's current IP address. • It may take some time to determine the IP address. If the IP address cannot be determined, the display will indicate "0.0.0.0".
Check MAC Address	-	Displays the machine's current MAC address.
DHCP	<u>ON</u> /OFF	Select "ON" to use the IP address assigned by the DHCP server.
AutoIP	<u>ON</u> /OFF	Select "ON" to use the IP address set by the AutoIP protocol. Note that DHCP takes priority if DHCP is set to "ON".
Ip Address	-	Sets the IP address used by the machine. • This can be set when both [DHCP] and [AutoIP] are disabled.
Default Gateway	-	Sets the default gateway used by the machine. • This can be set when both [DHCP] and [AutoIP] are disabled.
DNS Address	-	Sets the DNS server address used by the machine. • This can be set when both [DHCP] and [AutoIP] are disabled.
Sub Net Mask	-	Sets the subnet mask used by the machine. • This can be set when both [DHCP] and [AutoIP] are disabled.
Remote Control	-	An application (MRA: Mimaki Remote Access) is required to use the remote control function. MRA is a remote access tool installed on a computer or smartphone that allows viewing of product information and panel operation from a remote location away from the machine (within the same network segment).
Remote Control	<u>Enable</u> / Disable	Enable/disable remote control.







Item	Setting ^{*1}	Details
	PIN code	Enter the same PIN code as MRA. The PIN code is used for authentication between the machine and MRA. <ul style="list-style-type: none"> • When the machine is set to "0000", MRA can access the machine with any PIN code.
	KeyLife	Sets the time interval before disconnecting the machine and MRA if no operations are performed using MRA.
Machine Reset	-	Initializes the details set.

*1. The default settings are shown underlined.

3.5 Machine Status Menu

This is used to check machine information.

● Menu List

Item		Details
Usage	Roll Wiper Remain	Displays the remaining amount of cloth wiper. <ul style="list-style-type: none"> To reset the remaining amount of cloth wiper, press the [FUNC2] key while the amount is displayed.
	Waste Ink Tank	Displays the approximate level of waste ink in the waste ink tank as a percentage. <ul style="list-style-type: none"> To reset waste ink levels, press the [FUNC2] key while the level is displayed.
	Print Length	Displays the total length printed.
	Print Area	Displays the total area printed.
	Use Time	Displays the total time the power has been turned on.
	UV Lamp	Displays the total time the UV-LED lamp has been used.
	Capping Use Days	Displays the number of days since the cap was replaced.
Maintenance History	Maintenance	Displays a record of maintenance function execution (up to 10). <ul style="list-style-type: none"> Cleaning  P. 89, Wash Wiping  P. 89, Pump Tube Cleaning  P. 132, Nozzle Washing  P. 163, Circulation
	Replace Wiper	Displays a record of cloth wiper replacement (up to 5).  P. 142
	Ink replacement	Displays a record of ink pack replacement for each ink slot (up to 5).  "Replacing Ink"(P. 50) <ul style="list-style-type: none"> Slot 1 to 8
	Cap Replacement	Displays a record of cap replacement (up to 5).  P. 146
Version		Displays the machine firmware and other versions.
Error History		Displays the error and warning history. <ul style="list-style-type: none"> These are listed in chronological order. Use the keys to cycle through occurrence time/date and error/warning information.
List		This is used to print machine information.

Chapter 4 Maintenance



This chapter

To ensure years of precise performance, maintain the machine periodically based on frequency of use.

Read the maintenance precautions thoroughly before maintaining this product.

Maintenance Precautions	124	Replacement of Consumable Item	141
Maintenance Methods	125	Consumable Item Replacement Timing	141
Maintenance Items and Timing	125	Cloth Wiper Replacement	142
Ink Maintenance	126	Cap Replacement	146
Cap Rubber Cleaning	127	Replacing the Absorber Around the Station	
Carriage Underside Cleaning	127	148
Cloth Wiper Area Cleaning	129	Waste Ink Tank Replacement	150
NCU Cleaning	130	Mist Filter Replacement	153
DAS (Automatic Correction Function) Sensor		UV-LED Glass Replacement	154
Cleaning	131	Ink Bottle Cap Replacement	155
Ink Discharge Channel Cleaning	132		
Media Sensor Cleaning	132		
Jam Sensor Detecting Plate Cleaning	133		
Media Feeding Belt Cleaning	134		
Checking State of Media Feeding Belt Edges			
.....	134		
Cover (Exterior) Cleaning	136		
Cleaning the Mist Filter	137		
When this Printer is Left Unused for a Long			
Time	139		

4.1 Maintenance Precautions



- This machine includes parts that must be replaced periodically. We therefore recommend taking out a maintenance contract. Carry out maintenance periodically and replace consumable items to prevent quality defects and accidents.

⚠ WARNING



- Clean periodically. Debris and dust will accumulate on electrical components when the machine is used for extended periods. There is a risk of failure, electric shock, or fire due to current leakage.
- Do not clean by blowing—e.g., avoid using air blowers. Doing so may lead to failure, electric shock, or fire involving the machine if airborne debris or dust gets inside electrical components. Wipe using a soft cloth soaked in diluted neutral detergent and thoroughly wrung out. A vacuum cleaner may also be used for cleaning.



- Be careful to prevent liquids from getting inside the machine. Otherwise there is a risk of failure, electric shock, or fire.

⚠ CAUTION



- The UV-LED unit becomes extremely hot. Be careful not to touch the LED after it has been turned off until it has sufficiently cooled.



- For heavy soiling, wipe using a soft cloth soaked in diluted neutral detergent and thoroughly wrung out.



- Pay close attention to ventilation and be sure to wear safety glasses, gloves, and a mask when handling ink, maintenance liquid, waste ink, or other solutions used with the machine. Leaking ink may adhere to the skin or get into the eyes or mouth.







NOTICE



- Never touch the print head nozzle surface. Do not allow water or alcohol to come into contact with the print nozzle surface. This will increase the risk of machine failure or ejection failures (e.g., nozzle clogging or deflection).
- Do not use cotton swabs to clean around the head or carriage. Fibers from cotton swabs may adhere to the head nozzle surface and lead to ejection failures (e.g., nozzle clogging or deflection).
- Do not splash ink or maintenance liquid on the covers. Exposure to splashing ink or maintenance liquid may damage or deform the cover.
- Do not use benzine, thinner, or any chemical agent containing abrasives. Use of these chemicals may result in damage to or deformation of parts.
- Do not use organic solvents such as acetone and IPA. Doing so may damage the machine.
- Do not move the carriage by hand. To move the carriage, use the carriage out function on the menu.

4.2 Maintenance Methods

Maintenance Items and Timing

Timing	Item
Periodically	Shake the ink.  "Ink Maintenance" (P. 126)
At the start of the week's work	Maintain the white ink.  "White ink maintenance" (P. 126)
At the end of the week's work	Clean the cap rubber.  "Cap Rubber Cleaning" (P. 127)
	Clean the underside of the carriage.  "Carriage Underside Cleaning" (P. 127)
	Clean the underside of the UV-LED unit.  "Carriage Underside Cleaning" (P. 127)
	Check the waste ink levels in the waste ink tank.  "When "Check Waste Ink Tank" message appears" (P. 150)
Every month	Clean around the cloth wiper.  "Cloth Wiper Area Cleaning" (P. 129)
	Clean the NCU.  "NCU Cleaning" (P. 130)
	Clean the DAS sensor.  "DAS (Automatic Correction Function) Sensor Cleaning" (P. 131)
	Clean the ink discharge channel.  "Ink Discharge Channel Cleaning" (P. 132)
	Clean the media sensor.  "Media Sensor Cleaning" (P. 132)
	Clean the jam sensor detecting plate.  "Jam Sensor Detecting Plate Cleaning" (P. 133)
	Clean the platen.  "Media Feeding Belt Cleaning" (P. 134)
	Check the state of the left and right edges of the media feeding belt.  "Checking State of Media Feeding Belt Edges" (P. 134)
	Clean the cover (exterior).  "Cover (Exterior) Cleaning" (P. 136)
	Clean the mist filter. Soak up ink with a paper towel.  "Cleaning the Mist Filter" (P. 137)
When not used for more than a week	Clean the cap and wash the ink discharge channels. After cleaning, store without turning off the main power supply.  "When this Printer is Left Unused for a Long Time" (P. 139)

Items Required for Maintenance

To order replacement consumable items, contact your local dealer or our service office. For more information on consumable items, refer to our website (<https://mimaki.com/supply/inkjet.html>).



- Do not store consumable items in locations where children may enter.

Ink Maintenance

If ink constituents are sedimented, the ink density may become uneven. We recommend shaking the ink periodically to keep printing consistent.

UV ink: once a month.

UV white ink: once a day.



- The machine counts the time elapsed after the white ink was stirred. The "Shake White Ink Bottle" message appears when a preset count is reached. If the message appears, shake the white ink by following the instructions below:
Timing when the message appears: Every 24 hours (or when the power is turned on if the power was turned off).

1 Shake the ink bottle to the left and right slowly at least 20 times.

- Tighten the ink bottle lid securely, then shake the bottle slowly from left to right to ensure that the ink moves inside, holding the ink bottle lid with a piece of recommended non-woven fabric.

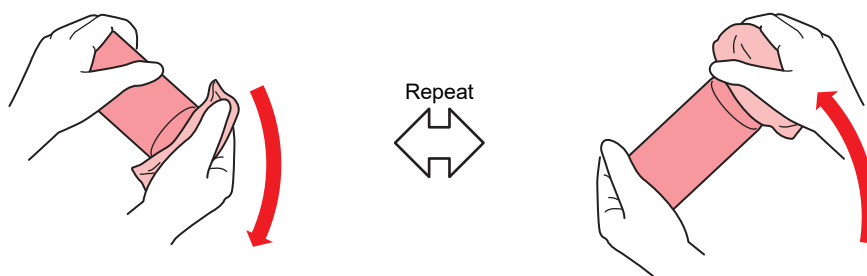

- Shake slowly. If the bottle is shaken too violently, ink may leak out or the air mixed in the ink may cause nozzle clogging.
- If the ink bottle is partially used, tilt it slowly until the ink bottle is upright.

White ink maintenance

White ink constituents are more easily sedimented than other ink colors. If ink constituents are sedimented, the ink density may become uneven. Perform maintenance once a week as follows before using the machine.

1 Shake the white ink eco-case or bottle.

- ["Ink Maintenance"\(P. 126\)](#)

2 On the LOCAL mode screen, select [MENU] > [Maintenance], then press the [ENTER] key.

- The Maintenance menu is displayed.

3 Select [White Maintenance], then press the [ENTER] key.

4 Press the [ENTER] key.

- Discharging/filling/cleaning starts automatically.
- The elapsed time is displayed.

Cap Rubber Cleaning

The cap prevents the print head nozzle surface from drying out. Continuing to use a dirty cap may affect ink take-up and lead to ejection failures (such as nozzle clogging or deflection).



- Be careful to avoid leaving fragments from the cleaning stick behind when cleaning. These fragments will increase the risk of ejection failures (e.g., nozzle clogging or deflection).

- 1 On the LOCAL mode screen, select [MENU] > [Maintenance], then press the [ENTER] key.**
 - The Maintenance menu is displayed.
- 2 Select [Station Maint.] > [Carriage Out] > [Move To Platen Right End], then press the [ENTER] key.**
 - The carriage moves over the platen.
- 3 Open the maintenance cover on the right side.**
- 4 Clean the cap rubber.**
 - Wipe off any ink and dust adhering using a cleaning stick moistened with maintenance liquid. Wipe off the maintenance liquid. Make sure none remains.
 - Clean the areas indicated in red in the diagram (the entire interior and exterior of the cap rubber, the tabs, and the mesh retainers).

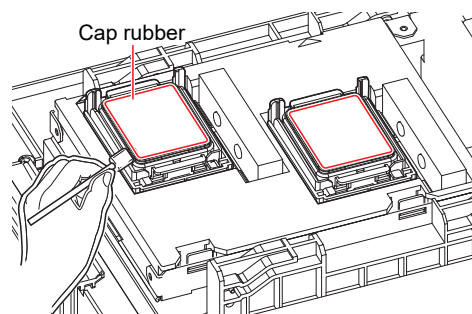

- 5 Close the maintenance cover, then press the [ENTER] key.**

Carriage Underside Cleaning

The underside of the carriage becomes coated with ink wiped off by the wiper. Continuing to use the dirty carriage underside will rub dried ink and attached dust on to the media, resulting in contaminated prints.

The print head uses an extremely delicate mechanism. Take great care when handling it.



- Be careful to avoid leaving fragments from the cleaning stick behind when cleaning. These fragments will increase the risk of ejection failures (e.g., nozzle clogging or deflection).

- 1 On the LOCAL mode screen, select [MENU] > [Maintenance], then press the [ENTER] key.**
 - The Maintenance menu is displayed.
- 2 Select [Station Maint.] > [Carriage Out] > [Move To Maint. Space], then press the [ENTER] key.**
 - The carriage moves to the maintenance space.

3 Open the maintenance cover on the left side.

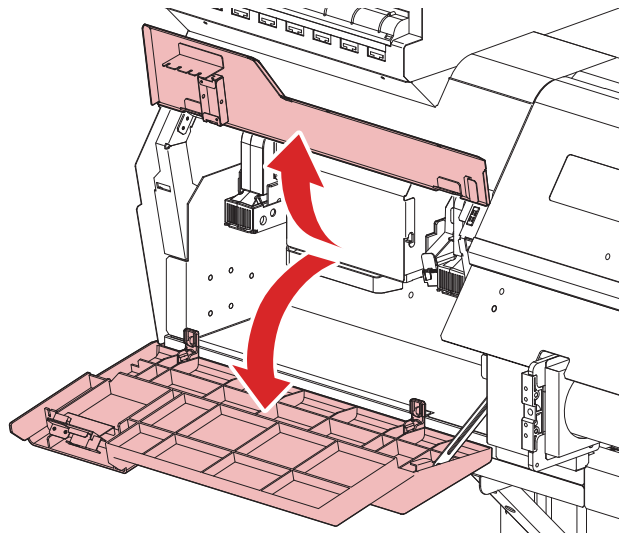

- After opening the maintenance cover on the left side, do not place objects on, rest your hands on, or apply force to the opened cover. Doing so may damage the maintenance cover.

4 Clean the UV-LED lamp glass surface.

- Wipe off any adhering ink using a cleaning stick moistened with maintenance liquid. Wipe off the maintenance liquid. Make sure none remains.

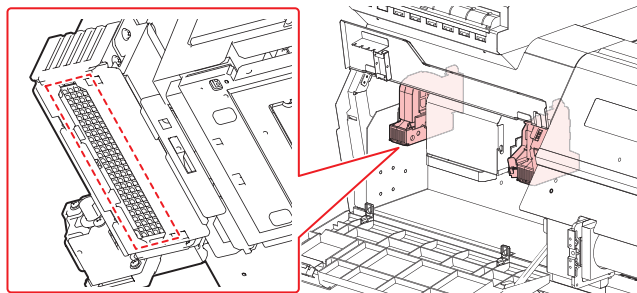

5 Clean around the print head.

- Wipe off any ink and dust adhering using a cleaning stick moistened with maintenance liquid. Wipe off the maintenance liquid. Make sure none remains.

Clean the print head sides and all around the nozzle plate using a cleaning stick.



Clean using a cleaning stick or soft cloth.



- Never touch the print head nozzles (areas indicated in blue in the diagram).

6 Once cleaning is complete, close the cover, then press the [ENTER] key.

Cloth Wiper Area Cleaning

Continuing to use while dirty will cause dried ink and attached dust around the wiper to rub against the head nozzle surface, and lead to ejection failures (e.g., nozzle clogging or deflection).



- Be careful to avoid leaving fragments from the cleaning stick behind when cleaning. These fragments will increase the risk of ejection failures (e.g., nozzle clogging or deflection).

1 On the LOCAL mode screen, select [MENU] > [Maintenance], then press the [ENTER] key.

- The Maintenance menu is displayed.

2 Select [Station Maint.] > [Carriage Out] > [Move To Platen Right End], then press the [ENTER] key.

- The carriage moves over the platen.

3 Open the maintenance cover on the right side.

4 Clean the wiper unit cover.

- Wipe off any ink and dust adhering using a cleaning stick moistened with maintenance liquid. Wipe off the maintenance liquid. Make sure none remains.

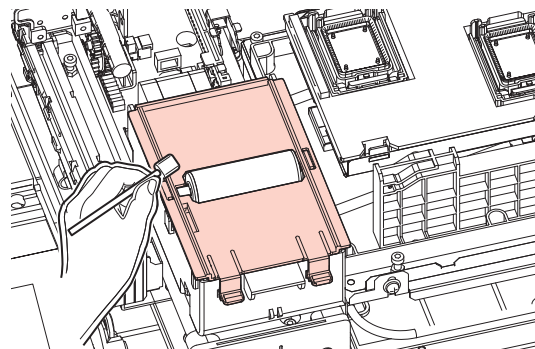

- Be careful to avoid splashing maintenance liquid on the cloth wiper.

5 Once cleaning is complete, close the cover, then press the [ENTER] key.

NCU Cleaning

The NCU uses a sensor to monitor the ink droplets ejected from the print head nozzles. Continuing to use the dirty NCU may prevent the nozzle check function from operating correctly.



- Be careful to avoid leaving fragments from the cleaning stick behind when cleaning. These fragments will increase the risk of ejection failures (e.g., nozzle clogging or deflection).

1 On the LOCAL mode screen, select [MENU] > [Maintenance], then press the [ENTER] key.

- The Maintenance menu is displayed.

2 Select [Station Maint.] > [Carriage Out] > [Move To Platen Right End], then press the [ENTER] key.

- The carriage moves over the platen.

3 Open the maintenance cover on the right side.

4 Clean the NCU.

- Wipe off any ink and dust adhering using a cleaning stick moistened with maintenance liquid. Wipe off the maintenance liquid. Make sure none remains.

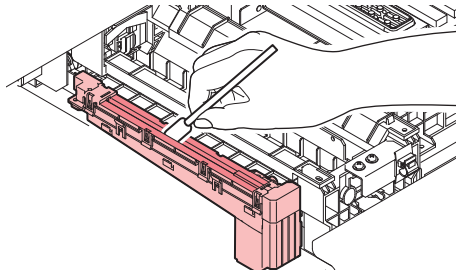

- Insert the cleaning stick as far as the line shown in the illustration.

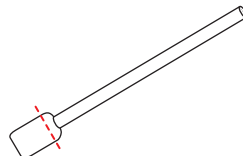

5 Once cleaning is complete, close the cover, then press the [ENTER] key.

DAS (Automatic Correction Function) Sensor Cleaning

The DAS sensor is located on the carriage underside. If dust or debris accumulates on the sensor, DAS () may not function.

- 1** On the **LOCAL** mode screen, select **[MENU] > [Maintenance]**, then press the **[ENTER]** key.
 - The Maintenance menu is displayed.
- 2** Select **[Station Maint.] > [Carriage Out] > [Move To Maint. Space]**, then press the **[ENTER]** key.
 - The carriage moves to the maintenance space.
- 3** Open the maintenance cover on the left side.

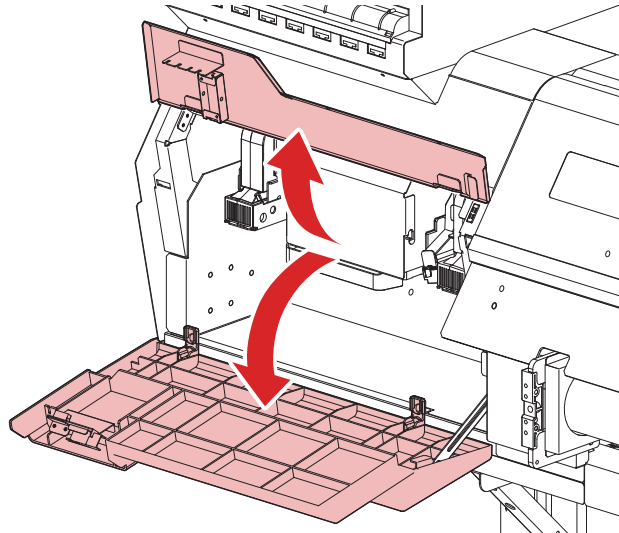

- After opening the maintenance cover on the left side, do not place objects on, rest your hands on, or apply force to the opened cover. Doing so may damage the maintenance cover.

- 4** Clean the DAS sensor.
 - Wipe clean using cotton swabs or a soft cloth.

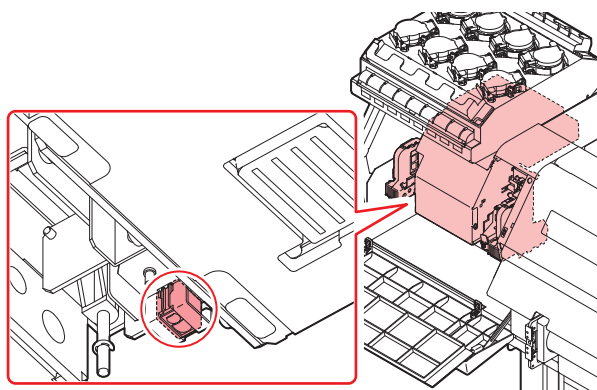

- For heavy soiling, wipe using a soft cloth soaked in diluted neutral detergent and thoroughly wrung out.

- 5** Once cleaning is complete, close the cover, then press the **[ENTER]** key.

Ink Discharge Channel Cleaning

Clean the ink discharge channel regularly to prevent clogging of the ink discharge channel below the cap.

- 1** On the LOCAL mode screen, select [MENU] > [Maintenance], then press the [ENTER] key.
 - The Maintenance menu is displayed.
- 2** Select [Station Maint.] > [Pump tube cleaning], then press the [ENTER] key.
 - The carriage moves over the platen.
 - "Fill the Liquid. Exit Next [ENT]" appears on the display.
- 3** Open the maintenance cover on the right side.
- 4** Check to confirm that approximately half a capful of maintenance liquid remains.
 - Use a syringe to draw up some maintenance liquid and drip in approximately half a capful.

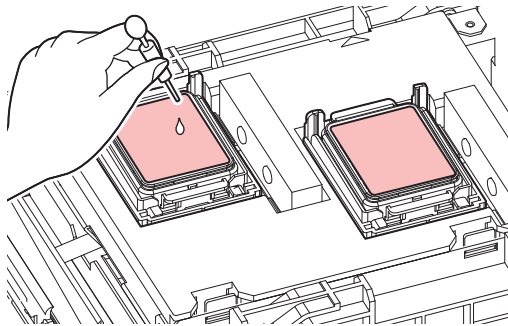

- 5** Close the maintenance cover, then press the [ENTER] key.
 - Pump tube (ink discharge channel below the cap) washing starts.

Media Sensor Cleaning

Media sensors are located on the rear covers. The media cannot be detected correctly if dust or debris accumulates on the sensors. Remove any debris using cotton swabs or a soft cloth.

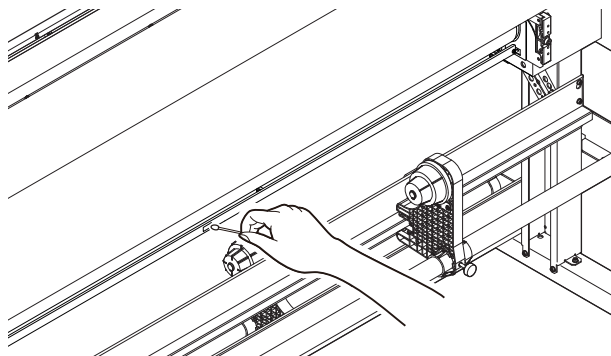

Jam Sensor Detecting Plate Cleaning

Continuing to use the dirty carriage underside will rub dried ink and attached dust on to the media, resulting in contaminated prints.

- 1** On the **LOCAL** mode screen, select **[MENU] > [Maintenance]**, then press the **[ENTER]** key.
 - The Maintenance menu is displayed.
- 2** Select **[Station Maint.] > [Carriage Out] > [Move To Maint. Space]**, then press the **[ENTER]** key.
 - The carriage moves to the maintenance space.
- 3** Open the maintenance cover on the left side.

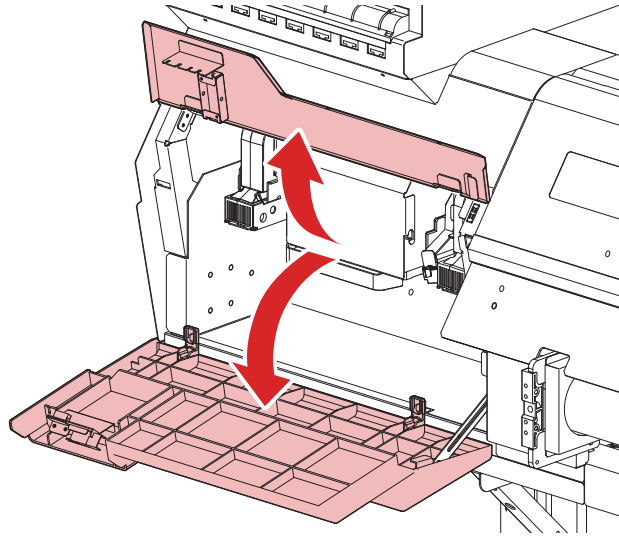

- After opening the maintenance cover on the left side, do not place objects on, rest your hands on, or apply force to the opened cover. Doing so may damage the maintenance cover.

4 Clean the jam sensor detecting plate.

- Clean the jam sensor detecting plate underside at the left and right sides of the carriage.
- Wipe off any ink and dust adhering using a cleaning stick moistened with maintenance liquid. Wipe off the maintenance liquid. Make sure none remains.

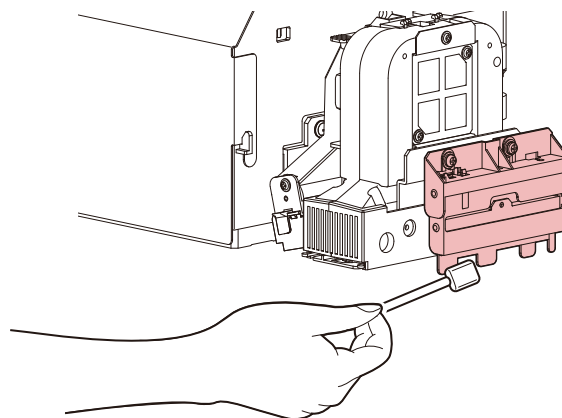

5 Once cleaning is complete, close the cover, then press the **[ENTER]** key.

Media Feeding Belt Cleaning

Continuing to use the dirty platen will prevent proper feeding of the media. It will also cause dried ink and attached dust to rub against the head nozzle surface and lead to ejection failures (e.g., nozzle clogging or deflection).

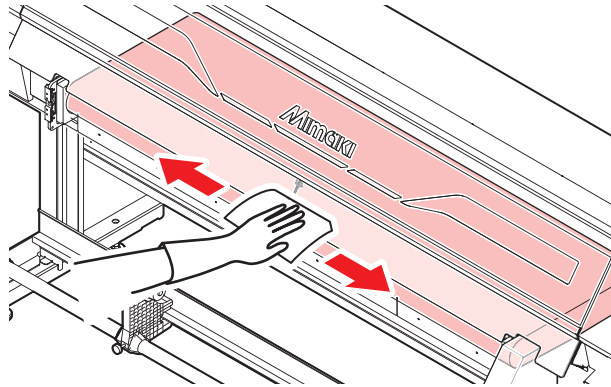

- Turn off the main power supply and unplug the power cable before carrying out maintenance.



- Be careful to prevent liquids from getting inside the machine. Otherwise there is a risk of failure, electric shock, or fire.



- For heavy soiling, wipe using a soft cloth soaked in diluted neutral detergent and thoroughly wrung out.



- Do not clean the printer unit or the media transport belt by spraying liquid on them, or by using alcohol-based solvents such as acetone, IPA, or ethanol.

Checking State of Media Feeding Belt Edges

The media feeding belt may become damaged with tears or fraying on the left and right edges of the mesh material. Damaged areas of the mesh material may come into contact with the head nozzle surface or may cause false detection of media jams.

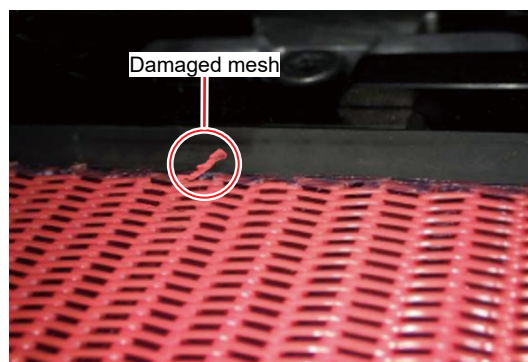

- Turn off the main power supply and unplug the power cable before carrying out maintenance.

- 1 Remove the media from the machine feeding belt.

2 Feed the belt in the feed direction, then check the left and right edges of the belt for damage to the mesh material such as shown in the figure above.

- Be sure to rotate the belt in the feed direction. Placing your hand over the front roller and feeding it toward you as if turning the roller will make the process easier.

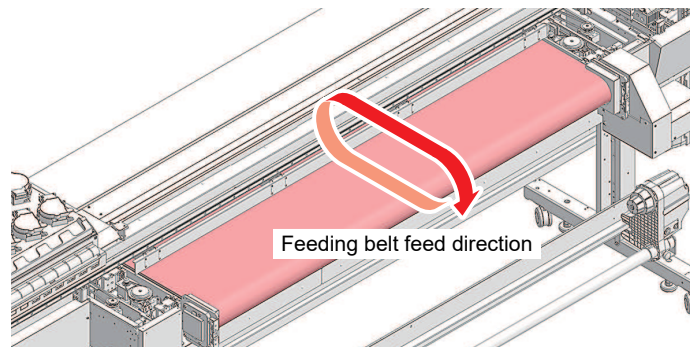

3 If there are any damaged areas in the mesh material, cut and remove them using nippers to leave the surface flat.

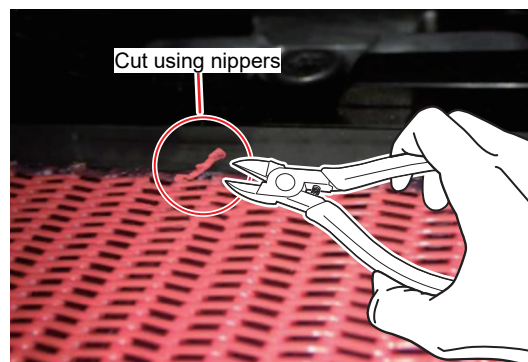

- When using nippers, take care not to cut your hands.

4 Perform the procedure in steps 2 to 3 for a full rotation of the belt.

5 Check to confirm that no cut pieces of mesh material have fallen onto the belt.

Cover (Exterior) Cleaning

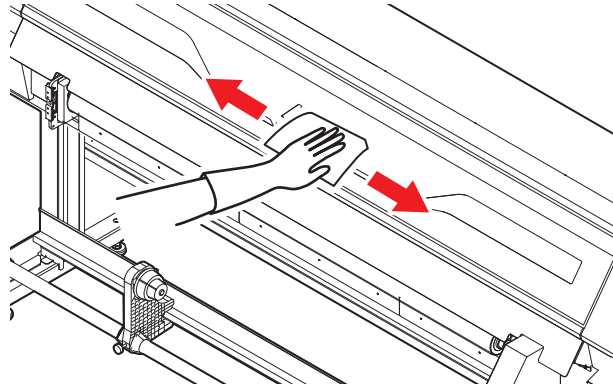

- Be careful to prevent liquids from getting inside the machine. Otherwise there is a risk of failure, electric shock, or fire.



- For heavy soiling, wipe using a soft cloth soaked in diluted neutral detergent and thoroughly wrung out.



- Do not clean the printer unit or the media transport belt by spraying liquid on them, or by using alcohol-based solvents such as acetone, IPA, or ethanol.

Cleaning the Mist Filter

The mist filter absorbs the mist generated when ink droplets are discharged from the print head. Continuing to use it when it is dirty will result in contaminated prints.

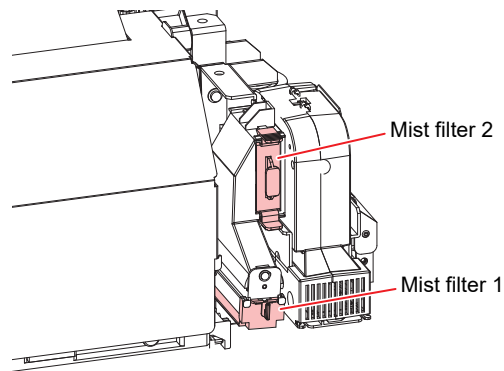

- 1** On the **LOCAL** mode screen, select **[MENU] > [Maintenance]**, then press the **[ENTER]** key.
 - The Maintenance menu is displayed.
- 2** Select **[Station Maint.] > [Carriage Out] > [Move To Maint. Space]**, then press the **[ENTER]** key.
 - The carriage moves to the maintenance space.
- 3** Open the maintenance cover on the left side.

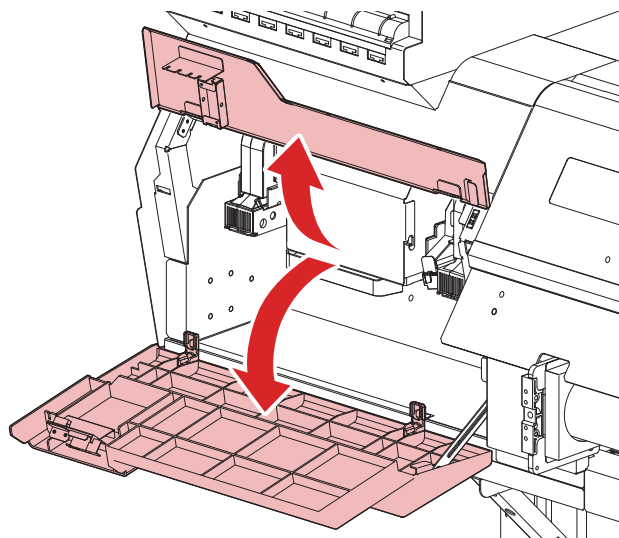

- After opening the maintenance cover on the left side, do not place objects on, rest your hands on, or apply force to the opened cover. Doing so may damage the maintenance cover.

4 Remove the mist filter.

- To remove the mist filter, pull the knob to the front while pushing the tab in the direction indicated by the arrow.

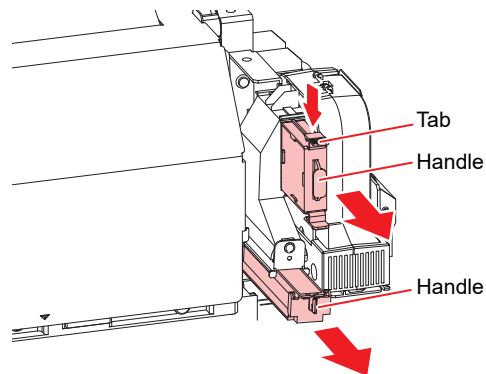

5 Clean the filter.

- Remove the filter and press down on it with a paper towel to remove dirt.
- Wipe off the dirt adhering to the filter case.



- Replace the mist filter if it gets very dirty—for example, due to liquefaction of ink adhering to the filter.

 ["Mist Filter Replacement"\(P. 153\)](#)

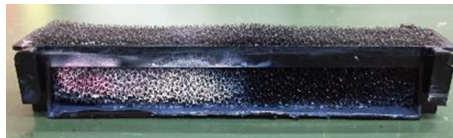

6 Reinstall the mist filter in its original position.

7 Once cleaning is complete, close the cover, then press the [ENTER] key.

When this Printer is Left Unused for a Long Time

Clean as follows if the product is not used for one week or longer:

Check beforehand

Is [Near End] or [Ink End] displayed?

- Maintenance liquid and ink is aspirated during the washing operation. Washing is not possible if an error occurs during this process. Replace with new ink.



- Do not turn off the main power supply. Turning off the main power supply will disable the automatic maintenance function (including nozzle clogging prevention function and ink discharge channel cleaning function). This increases the risk of ejection failures (such as nozzle clogging or deflection).

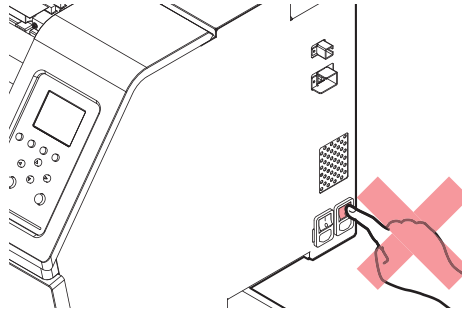

- Do not leave media loaded on the platen. This may leave irregularities or ripples in the media.



- Perform the following if the "Check Waste Ink Tank" message appears on the display.
 ["Waste Ink Tank Replacement"\(P. 150\)](#)

- 1 On the LOCAL mode screen, select [MENU] > [Maintenance], then press the [ENTER] key.**
 - The Maintenance menu is displayed.
- 2 Select [Station Maint.] > [Custody Wash], then press the [ENTER] key.**
 - The carriage moves over the platen.
- 3 Open the maintenance cover on the right side.**
- 4 Clean the cap rubber.**
 -  ["Cap Rubber Cleaning"\(P. 127\)](#)
- 5 Press the [ENTER] key once cleaning is complete.**
 - "Fill the Liquid. Exit Next [ENT]" appears on the display.

6 Fill the cap with maintenance liquid.

- Use a syringe to draw up some maintenance liquid and fill until it almost overflows from the cap.

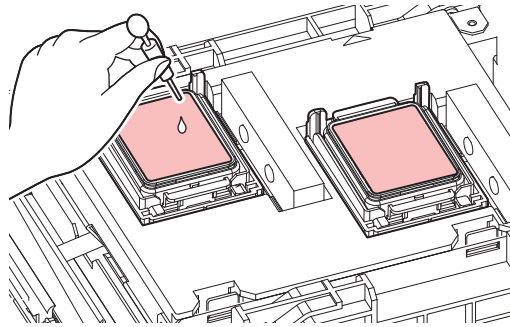

7 Close the maintenance cover, then press the [ENTER] key.

8 Set the exposure time, then press the [ENTER] key.

- Cleaning is performed automatically once print nozzle washing has ended.
- "Fill the Liquid. Exit Next [ENT]" appears on the display.

9 Open the maintenance cover on the right side.

10 Fill the cap with maintenance liquid.

- Use a syringe to draw up some maintenance liquid and fill until it almost overflows from the cap.

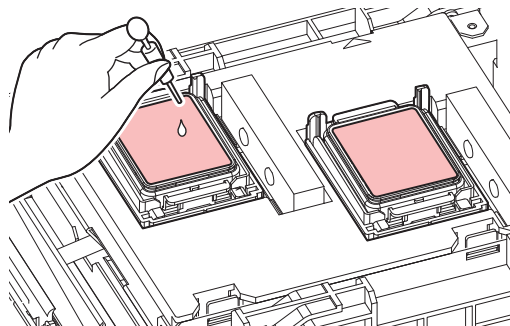

11 Close the maintenance cover, then press the [ENTER] key.

- Pump tube (ink discharge channel below the cap) washing starts.

4.3 Replacement of Consumable Item

To order replacement consumable items, contact your local dealer or our service office. For more information on consumable items, refer to our website (<https://mimaki.com/supply/inkjet.html>).



- Do not store consumable items in locations where children may enter.



- When disposing of consumable items, contact an industrial waste disposal operator or dispose of the product in accordance with the local laws and regulations.

Consumable Item Replacement Timing

Timing	Item
When run out	"Cloth Wiper Replacement"(P. 142)
When dirty	"Replacing the Absorber Around the Station"(P. 148) "Mist Filter Replacement"(P. 153) "UV-LED Glass Replacement"(P. 154)
When ejection failures cannot be remedied	"Cap Replacement"(P. 146)
When damaged	"Cap Replacement"(P. 146)
When "Check Waste Ink Tank" appears on the display	"Waste Ink Tank Replacement"(P. 150)
Periodically	"Ink Bottle Cap Replacement"(P. 155)

Cloth Wiper Replacement

Replace cloth wipers with new ones when they have run out.



- **The cloth wipers to use depend on the model.** Using inappropriate cloth wipers may damage the print head.

Model	Code/Package type
UJ330H	 <p>SPC-0919/Aluminum pack</p>



SPC-0919 cloth wipers

- Precautions are included with the cloth wipers. Thoroughly read them and make sure you understand the contents.
- When disposing of cloth wipers, **be sure to place them in a sealed bag.** Contact an industrial waste disposal operator or dispose of in accordance with the local laws and regulations.
- When handling cloth wipers, ensure adequate ventilation and take care not to inhale the solvent fumes.



- When handling **SPC-0919 cloth wipers**, be sure to wear safety glasses, gloves, and a mask. There is a risk of the liquid (solvent) contained in cloth wipers splashing and contacting your skin, eyes, or mouth.



- 1 "Wiper End" appears on the display.
- 2 On the LOCAL mode screen, select [MENU] > [Maintenance], then press the [ENTER] key.
 - The Maintenance menu is displayed.
- 3 Select [Station Maint.] > [Replace Wiper], then press the [ENTER] key.
 - The carriage moves over the platen.
- 4 Open the maintenance cover on the right side.

5 Open the cloth wiper cover.

- Push the two tabs at the front up to open.

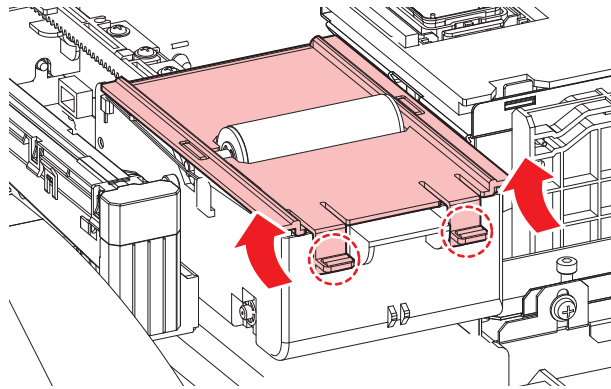

6 Remove the wiper together with the spindle.

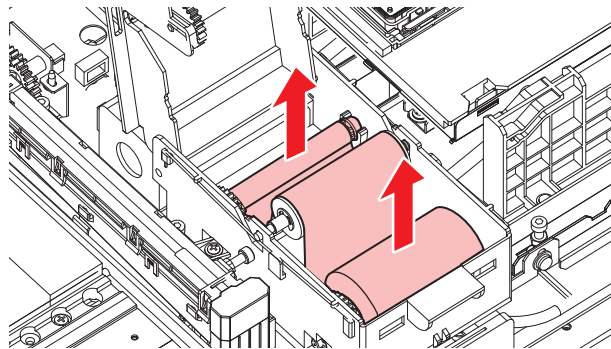

7 Remove the wiper from the spindle.



- When disposing of ink, maintenance liquid or other liquid used with the product, or the container or paper towel to which ink or other liquid is attached, contact an industrial waste disposal operator or dispose of the product in accordance with the local laws and regulations.

8 Clean the wiper unit underside.

- Wipe off any ink and dust adhering using a cleaning stick moistened with maintenance liquid. Wipe off the maintenance liquid. Make sure none remains.

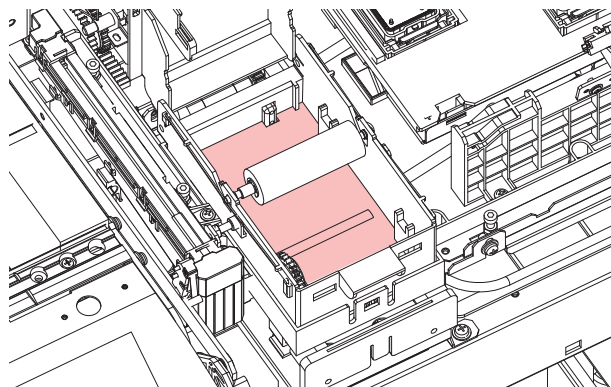

9 Clean the wipe roller.

- Wipe off any ink and dust adhering using a cleaning stick moistened with maintenance liquid. Wipe off the maintenance liquid. Make sure none remains.

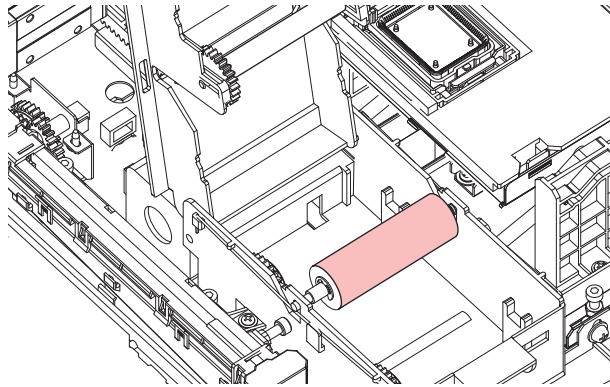

10 Clean the pinch rollers.

- Gently wipe off any dust adhering with a soft cloth.

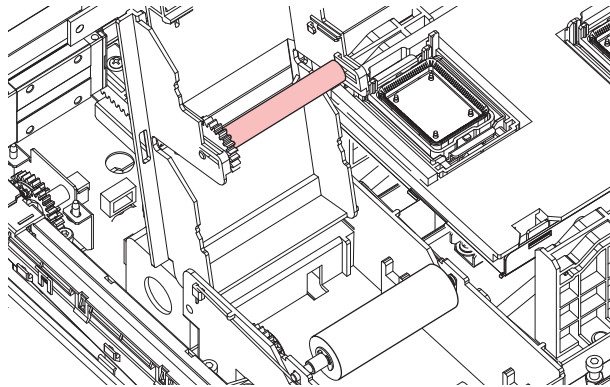

- Do not wipe too hard. Wiping too hard may degrade the sponge.

11 Mount a new cloth wiper.

- (1) Remove the cloth wiper from the bag.
- (2) Unroll the side with more cloth on it.

[When removed from bag]

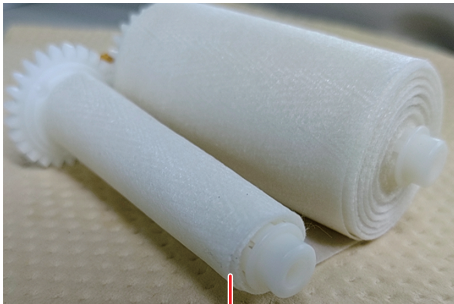

Wound approximately three times

[When mounted in the wiper unit]

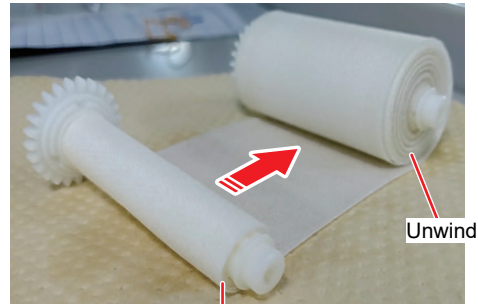

Do not unwind!

- (3) Mount a new cloth wiper.

- Mount the cloth wiper with the gear on the left.

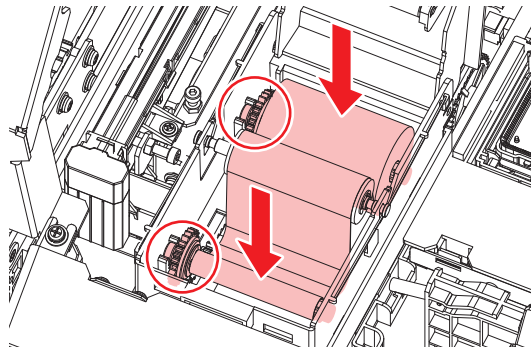

Important!

- If no cloth is wound around the spindle, wind the cloth around the spindle three times before mounting. If the cloth is mounted with no cloth wound around the spindle, the cloth may become detached from the wiper unit.

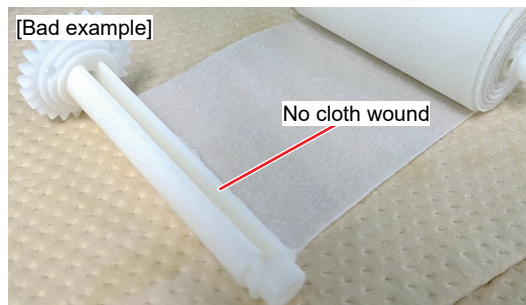

12 Close the cloth wiper cover.

13 Close the maintenance cover, then press the [ENTER] key.

- The remaining amount of cloth wiper is reset.

Cap Replacement

If ejection failures (e.g., nozzle clogging or deflection) remain unresolved even after cleaning, replace with a new cap.



- Be sure to replace the cap if you observe any scratches or other damage on the rim.

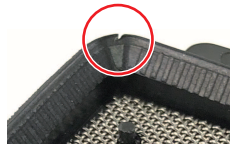

- Perform a cap suction check to determine whether the cap needs to be replaced.  ["Cap Suction Check"\(P. 116\)](#)

- 1 On the LOCAL mode screen, select [MENU] > [Maintenance], then press the [ENTER] key.**
 - The Maintenance menu is displayed.
- 2 Select [Station Maint.] > [Replace Cap], then press the [ENTER] key.**
 - The carriage moves over the platen.
- 3 Open the maintenance cover on the right side.**
- 4 Remove the cap.**
 - Squeeze the lugs on either side of the cap and pull off.

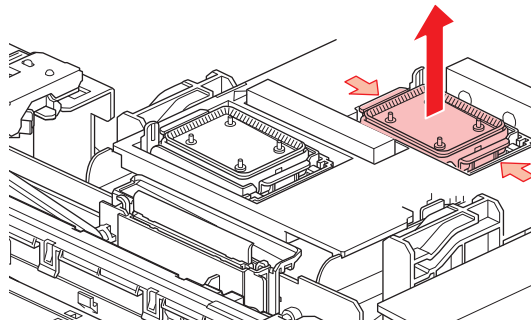

- 5 Apply maintenance liquid.**
 - Use a syringe to apply two or three drops of maintenance liquid to the hole at the front.

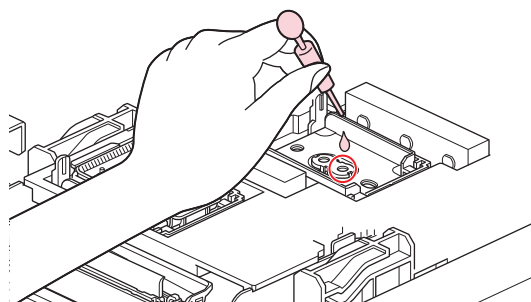

6 Mount a new cap.

- Position with the slot at the front and push in until it clicks.

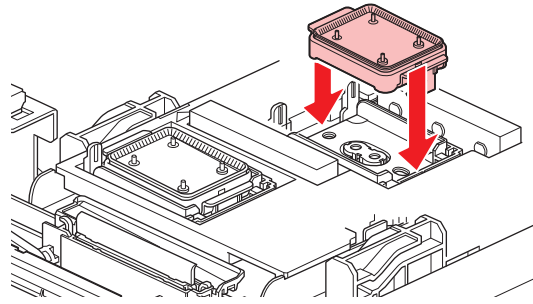

7 Once replacement is complete, close the cover, then press the [ENTER] key.

Replacing the Absorber Around the Station

If the cap absorber or maintenance liquid absorber is very dirty or if ink drips on to the media, replace with a new cap absorber.

- 1** On the **LOCAL** mode screen, select **[MENU] > [Maintenance]**, then press the **[ENTER]** key.
 - The Maintenance menu is displayed.
- 2** Select **[Station Maint.] > [Carriage Out] > [Move To Platen Right End]**, then press the **[ENTER]** key.
 - The carriage moves over the platen.
- 3** Open the maintenance cover on the right side.
- 4** Remove the cap absorber together with the plate.
 - Push up the two tabs at the front to remove the cap absorber.

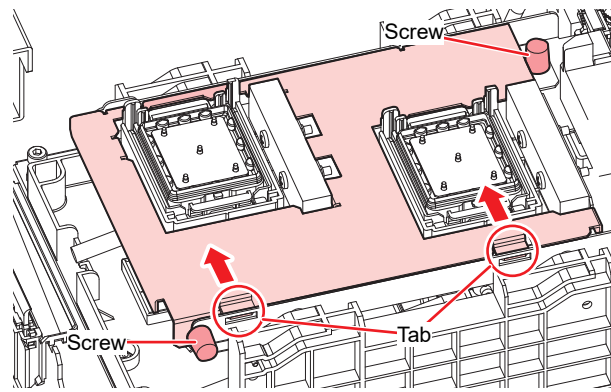

- Avoid ink dripping when removing the cap absorbers.

- 5** Clean the cap base.

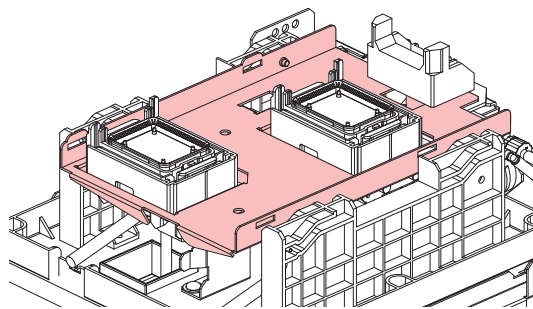

6 Mount a new cap absorber (with plate).

- Push the tabs on the cap absorber into the slits at the rear of the C slider, and clip in the tabs at the front.

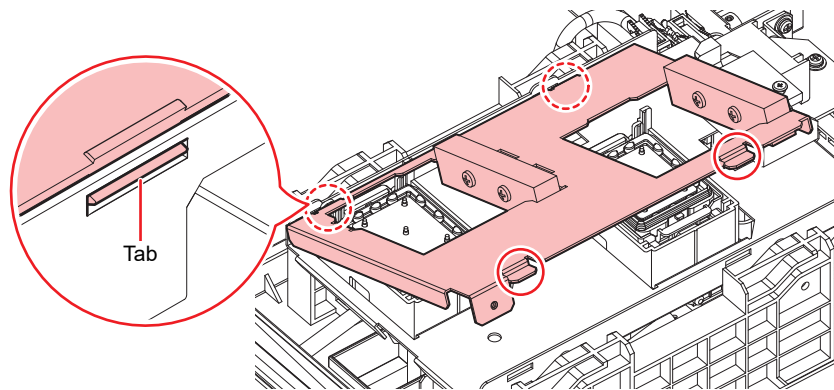

7 Once replacement is complete, close the cover, then press the [ENTER] key.

Waste Ink Tank Replacement

Ink used during head cleaning and other processes is collected in the waste ink tank at the lower right of the machine.

This product keeps track of the waste ink level. A "Check Waste Ink Tank" message appears when the preset level is reached. Use this a guide for replacing the waste ink tank.



- For a 2-liter tank, the preset level is 80 % (1.6 L).
- Continuing to use the product without disposing of the waste ink may result in waste ink overflowing from the waste ink tank. Visually check ink levels in the waste ink tank about once a week.



- Pay close attention to ventilation and be sure to wear safety glasses, gloves, and a mask when handling ink, maintenance liquid, waste ink, or other solutions used with the machine. Leaking ink may adhere to the skin or get into the eyes or mouth.



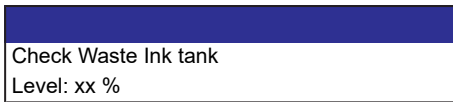

When "Check Waste Ink Tank" message appears

- 1 The "Check Waste Ink Tank" message appears on the display.



Check Waste Ink tank
Level: xx %

- 2 Check the waste ink levels in the waste ink tank.
 - If you note any discrepancies from actual levels, proceed to the next step.
 - If there is no discrepancy, replace (dispose of) the waste ink tank referring to  ["Replacing the Waste Ink Tank"](#)(P. 150).
- 3 On the LOCAL mode screen, select [MENU] > [Maintenance], then press the [ENTER] key.
 - The Maintenance menu is displayed.
- 4 Select [Waste Ink Tank], then press the [ENTER] key.
- 5 Select [Adjust Waste Ink Volume], then press the [ENTER] key.
- 6 Press   to adjust the level.
- 7 Press the [ENTER] key once adjustment is complete.

Replacing the Waste Ink Tank

- 1 On the LOCAL mode screen, select [MENU] > [Maintenance], then press the [ENTER] key.
 - The Maintenance menu is displayed.
- 2 Select [Waste Ink Tank], then press the [ENTER] key.
- 3 Select [Reset Waste Ink Volume], then press the [ENTER] key.

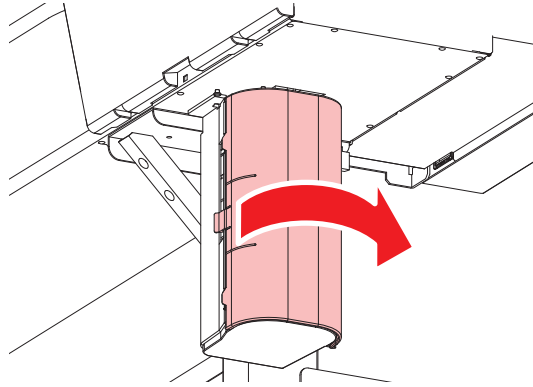
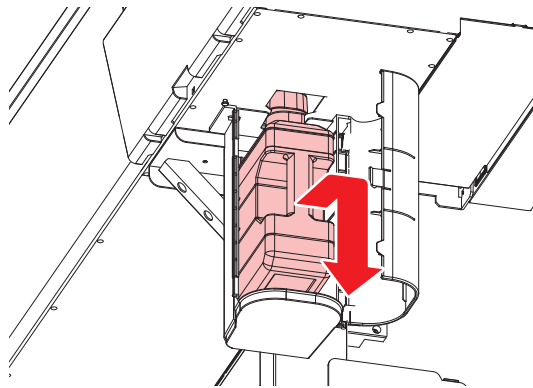
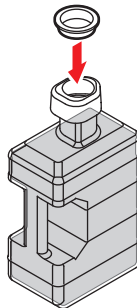
4 Open the waste ink tank cover.**5** Hold the handle on the waste ink tank and slide out.**6** Attach the cap to the removed waste ink tank, and use tape to prevent leakage of waste ink.

- When disposing of ink, maintenance liquid or other liquid used with the product, or containers or non-woven fabric contaminated with ink or other liquid, contact an industrial waste disposal operator or dispose of the product in accordance with the local laws and regulations.

7 Install a new waste ink tank.

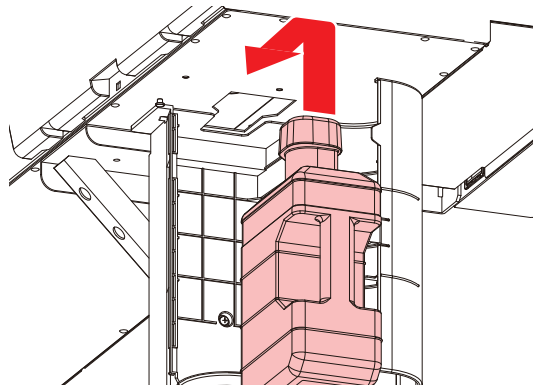

8 Close the waste ink tank cover.

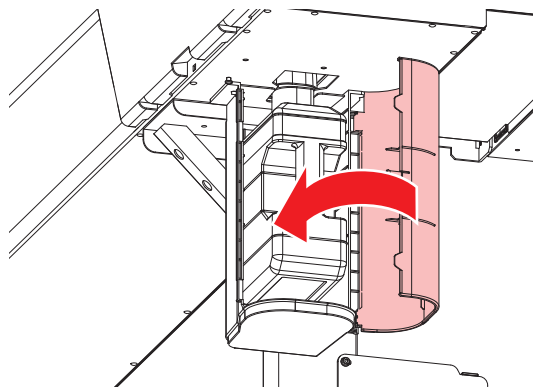

9 Press the [ENTER] key.

- The waste ink level will be reset.

Mist Filter Replacement

Check the mist filter. Replace if very dirty.

- 1** On the **LOCAL** mode screen, select **[MENU] > [Maintenance]**, then press the **[ENTER]** key.
 - The Maintenance menu is displayed.
- 2** Select **[Station Maint.] > [Carriage Out] > [Move To Maint. Space]**, then press the **[ENTER]** key.
 - The carriage moves to the maintenance space.
- 3** Open the maintenance cover on the left side.

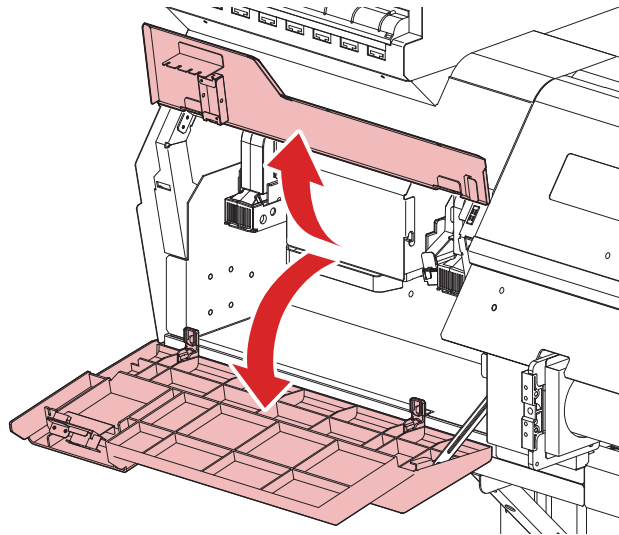

- After opening the maintenance cover on the left side, do not place objects on, rest your hands on, or apply force to the opened cover. Doing so may damage the maintenance cover.

4 Remove the mist filter box.

- Push the tab in the direction indicated by the arrow and slide out in the direction of the arrow to remove.

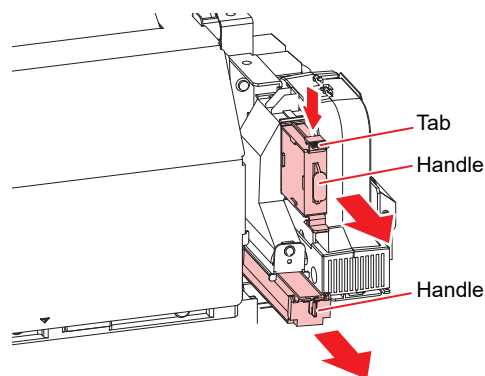

5 Replace the mist filter with a new one.

6 Install the mist filter box.

- Insert until it clicks into place. Confirm that the tab is engaged.

7 Once replacement is complete, close the cover, then press the **[ENTER]** key.

UV-LED Glass Replacement

Replace the glass on the underside of the UV-LED unit if hardened ink is adhering to it.

- 1** On the **LOCAL** mode screen, select **[MENU] > [Maintenance]**, then press the **[ENTER]** key.
 - The Maintenance menu is displayed.
- 2** Select **[Station Maint.] > [Carriage Out] > [Move To Platen Right End]**, then press the **[ENTER]** key.
 - The carriage moves over the platen.
- 3** Open the front cover.
- 4** Remove the LED glass.
 - Push the tabs inward and slide out the glass in the direction of the arrow to remove.
 - Be careful not to apply too much force when unclipping the tabs. Disregarding this precaution may result in breakage of the tabs.

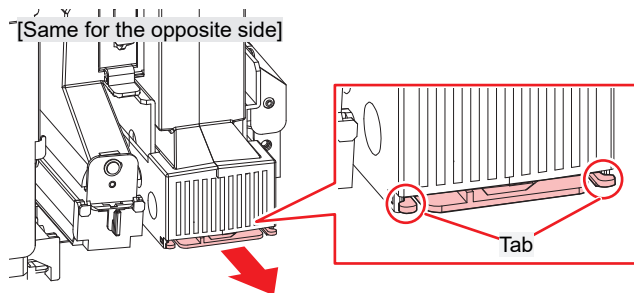

- 5** When replacing the glass holder at the same time, cut the tabs on the rear side.

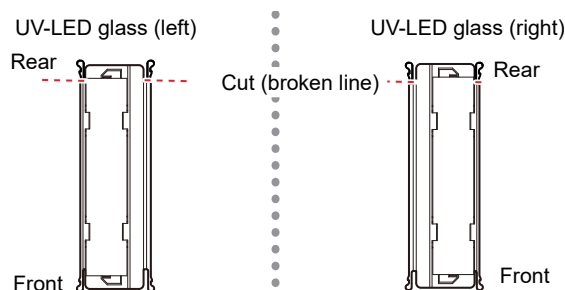

- 6** Install a new LED glass.
 - Without touching the tabs, press on the center of the glass holder to insert it into place.
 - Insert until it clicks into place. Confirm that the tabs are engaged.

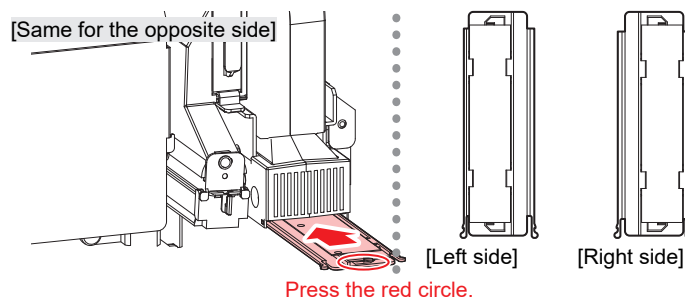

- 7** Once replacement is complete, close the cover, then press the **[ENTER]** key.

Ink Bottle Cap Replacement



- Pay close attention to ventilation and be sure to wear safety glasses, gloves, and a mask when handling ink, maintenance liquid, waste ink, or other solutions used with the machine. Leaking ink may adhere to the skin or get into the eyes or mouth.



Chapter 5 Troubleshooting



This chapter

This chapter describes corrective actions for troubleshooting and messages on the display.



Troubleshooting.....	158	Abnormal noise occurs during cleaning	167
The power does not turn on.	158	To Stop Circulation Operation	168
Printing is not possible.	158	Problems Causing Messages to Appear	169
The media jams or the media is dirty.	158	Warning Messages	169
Trouble with the Media Feeding Belt.....	159	Ink Error	170
Image defects occur.....	161	Error Message	171
The ink has leaked out.....	166	SYSTEM HALT	180
The light-blocking cover comes off.....	166		

5.1 Troubleshooting





For information on troubleshooting, refer to this chapter. Refer to our website (<https://mimaki.com/support/>) for frequently asked questions (FAQs) about this product and customer support videos.

If the recommended corrective action does not resolve the problem, contact your local dealer or our service office.



The power does not turn on.

Points to check	Corrective action
Is the machine connected to the power outlet by the power cable?	Connect the power plug securely to the power outlet.  "Connecting the Power Cable"(P. 41)
Are you using the power cable provided?	Use the power cable provided.
Is the main power supply turned on?	Turn on the main power supply.  "Turning On the Power"(P. 41)
Is the [END/POWER] key on the operating panel turned on?	Turn the power on.  "Turning On the Power"(P. 41)

Printing is not possible.

Points to check	Corrective action
Is a USB interface cable connected?	Connect the cable securely to the USB 2.0 port.  "Using a USB Cable"(P. 45)
Is a LAN cable connected?	Connect the cable securely to the LAN port.  "Using a LAN Cable"(P. 44)
Are you using a LAN cable approved by Mimaki?	Check the LAN cable type.  "Using a LAN Cable"(P. 44)
Is the status lamp on the operating panel illuminated or flashing red?	An error has occurred. Check the message on the display.  "Operating Panel"(P. 38)

The media jams or the media is dirty.

Points to check	Corrective action
Are you using the recommended media?	Make sure you are using the recommended media. https://mimaki.com/supply/inkjet.html
Are you using curled media?	Do not use curled media or media with folded ends.
Is the media skewed?	Use the take-up unit to adjust the media or reload the media.  "Loading the Media"(P. 62)
Is the media lifting up and rubbing against the carriage or head?	<ol style="list-style-type: none"> 1. Ensure that the installation environment satisfies the requirements.  "Specifications"(P. 182) 2. Raise the head gap.

Trouble with the Media Feeding Belt

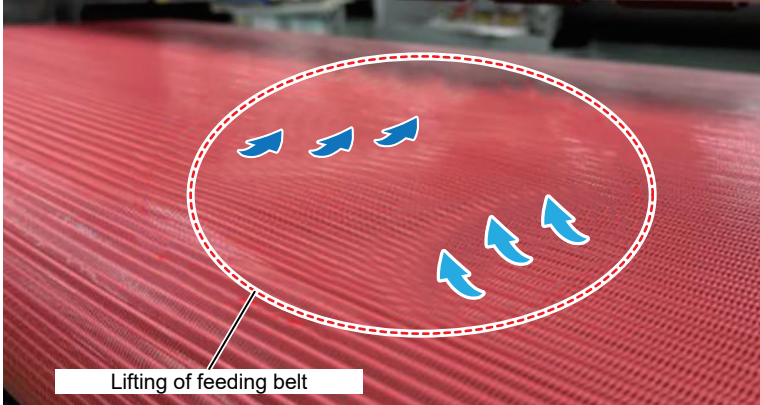
Symptom	Corrective action
Printing is accidentally performed directly on the media feeding belt.	<p>If printing is mistakenly done on the media feeding belt, wear protective gloves and safety goggles, then wipe the ink-stained area of the belt surface using a cloth (or paper) that does not produce lint or paper dust, lightly moistened with a neutral detergent or industrial alcohol.</p> <p>Never use maintenance cleaning fluid when wiping off the ink. Using such fluid may damage the surface of the media feeding belt.</p> <p>Please note that the longer the time elapsed after printing, the more difficult it becomes to remove the ink stains.</p>
Damage is found on the edges of the media feeding belt.	<ol style="list-style-type: none"> If fraying or damage is observed on the left or right edges of the mesh material of the media feeding belt, the damaged area may come into contact with the printhead nozzle surface or may cause false detection of a media jam. ☞ "Checking State of Media Feeding Belt Edges"(P. 134) Refer and perform the required maintenance procedures. If the damage is severe, contact your authorized dealer or the nearest sales office of our company.
Media lifting occurs on the belt.	<ol style="list-style-type: none"> Check the height of the media lifting on the media feeding belt. If the lifting height is low enough that the media does not come into contact with the printhead or the positioning bar, the printer can continue to be used as is, as it does not affect printing operations.  <ol style="list-style-type: none"> If the degree of lifting is severe and affects printing, contact your authorized dealer or the nearest sales office of our company.



Symptom	Corrective action
<p>The belt is meandering, and a Meander Limit Response Error has occurred.</p>	<ol style="list-style-type: none"> 1. The printer controls belt meandering by detecting the left and right edges of the belt using sensors. Check the following points to ensure that conditions causing false sensor detection are not present. <ul style="list-style-type: none"> – The positions of the left and right edges of the belt <div style="display: flex; align-items: flex-start; margin-top: 10px;"> <div style="margin-right: 10px;">[Feeding belt left edge]</div>  </div> – Whether there is any dirt, debris, or dust around the meander detection sensors <div style="display: flex; align-items: flex-start; margin-top: 10px;">  </div> 2. Run [Maintenance] > [Meander Recovery Action], and check whether the left and right belt positions return to their normal positions. 3. If the belt position does not recover after performing the Meander Recovery Action, or if the error occurs frequently, contact your authorized dealer or the nearest sales office of our company.

Image defects occur.

Symptom	Corrective action
White streaks, blurriness, and dark streaks occur. (Carriage scan direction)	<ol style="list-style-type: none"> 1. Remove any paper scraps or other debris adhering to areas over which the head passes. ☞ "Media Feeding Belt Cleaning"(P. 134) 2. Perform the procedure described in ☞ "Head Cleaning"(P. 89). 3. Perform the procedure described in ☞ "Feed Correction"(P. 92). 4. Perform the procedure described in ☞ "Cap Rubber Cleaning"(P. 127). 5. Perform the procedure described in ☞ "Carriage Underside Cleaning"(P. 127).
Text is double- or triple-printed in the media feed direction.	<ol style="list-style-type: none"> 1. Perform the procedure described in ☞ "Feed Correction"(P. 92).
Offsetting occurs during bidirectional printing.	<ol style="list-style-type: none"> 1. Perform the procedure described in ☞ "Correcting the Drop Position"(P. 94).
Ink droplets drip during printing.	<ol style="list-style-type: none"> 1. Perform the procedure described in ☞ "Cap Rubber Cleaning"(P. 127). 2. Perform the procedure described in ☞ "Carriage Underside Cleaning"(P. 127). 3. Perform the procedure described in ☞ "Head Cleaning"(P. 89). 4. Set auto maintenance. ☞ "Maintenance Menu"(P. 112)
Nozzles are clogged.	<ol style="list-style-type: none"> 1. Perform the procedure described in ☞ "Head Cleaning"(P. 89). 2. Perform the procedure described in ☞ "Print Head Nozzle Washing"(P. 163). 3. Perform the procedure described in ☞ "Registering Nozzle Recovery"(P. 114).
Are the print heads too high?	Adjust the print head height. ☞ "Adjusting Print Head Height"(P. 60) If the print head height cannot be lowered, perform regular test printing to check for nozzle clogging.
Are you using media easily affected by static electricity?	Perform a test print periodically to confirm that the nozzles are not clogged. Otherwise, use an optional ionizer.
Is the machine installed in a location with low humidity?	Increase the humidity by installing a humidifier or similar equipment. When printing continuously, also increase the refresh level during printing (☞ P. 113) or perform regular test printing to check for nozzle clogging. Otherwise, use an optional ionizer.
Is the machine installed in a location where dust or powder is present?	Install the machine in a location free of dust or powder (office equivalent: dust level 0.15 mg/m ³).
Are you using media such as mirrors, polished stainless steel plate, or gold/silver foil?	If you are using reflective media, perform regular test printing to check for nozzle clogging.
Are you using textured media?	Textured media will reflect more light than flat media. To reduce reflected light from areas other than the media, load spare media (something thinner than the media to be printed on) on the suction surface of the table when no media is loaded, ensuring the surface is as flat as possible.
There is considerable nozzle clogging with white ink	<ol style="list-style-type: none"> 1. Perform the procedure described in ☞ "Head Cleaning"(P. 89). 2. Perform the procedure described in ☞ "There is considerable nozzle clogging with white ink"(P. 164).
Uneven coloring looking like tree rings occurs.	<ol style="list-style-type: none"> 1. Check the ambient temperature. ☞ "Installation Precautions"(P. 22) This issue tends to occur more when the ambient temperature is low. 2. Enable the ink-saving function in the MIMAKI RIP software (RasterLink). This generally reduces problem occurrence.

Symptom	Corrective action
	

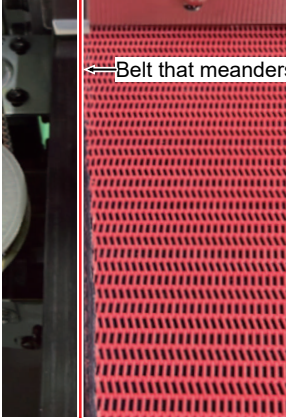
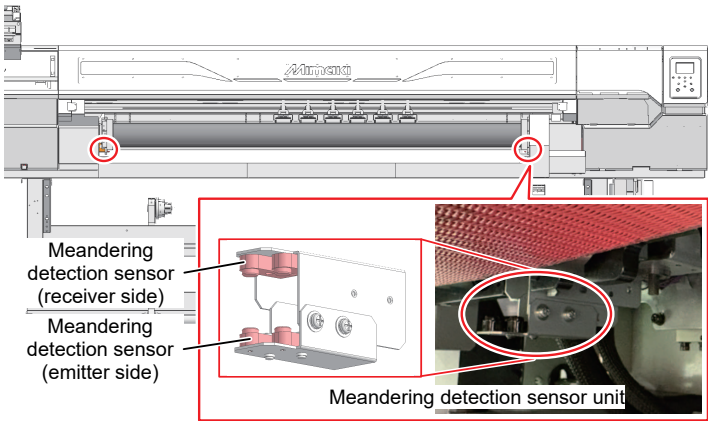
Print Head Nozzle Washing

If ejection failures (e.g., nozzle clogging or deflection) remain unresolved even after head cleaning (Head Cleaning), apply nozzle wash to the print head.

- 1** On the LOCAL mode screen, select [MENU] > [Maintenance], then press the [ENTER] key.
 - The Maintenance menu is displayed.
- 2** Select [Station Maint.] > [Nozzle Wash], then press the [ENTER] key.
 - The carriage moves over the platen.
- 3** Open the maintenance cover on the right side.
- 4** Clean the cap rubber.
 - Cap Rubber Cleaning
- 5** Press the [ENTER] key once cleaning is complete.
 - "Fill the Liquid. Exit Next [ENT]" appears on the display.
- 6** Fill the cap with maintenance liquid.
 - Use a syringe to draw up some maintenance liquid and fill until it almost overflows from the cap.

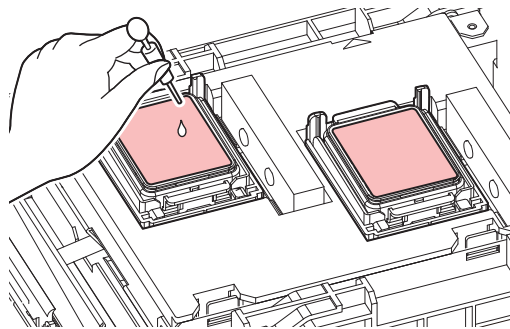

- 7** Close the maintenance cover, then press the [ENTER] key.
- 8** Set the exposure time, then press the [ENTER] key.
 - Cleaning is performed automatically once print nozzle washing has ended.



- If ejection failures (e.g., nozzle clogging or deflection) remain unresolved even after washing the nozzles several times, contact your local dealer or our service office.

There is considerable nozzle clogging with white ink

If there is a large amount of white ink causing nozzle clogging (major clog), and this cannot be resolved by refilling individual ink cartridges, please bleed the system. Note that this consumes a large amount of ink.

1 On the LOCAL mode screen, select [MENU] > [Maintenance], then press the [ENTER] key.

- The Maintenance menu is displayed.

2 Select [Air PG], then press the [ENTER] key.

3 Press , then select [YES].

Air PG	
It will use a lot of ink.	
Execute ?	
NO <	> YES



4 Press , then select [YES].

Air PG	
Do ejection failures involving large amounts of white occur?	
NO <	> YES

5 The "Check Waste Ink Tank" message appears on the display.

Check Waste Ink tank	
Level: xx %	

6 Check the waste ink levels in the waste ink tank.

- If there are discrepancies from actual levels, correct the waste ink amount.  ["When "Check Waste Ink Tank" message appears"\(P. 150\)](#)
- If there is no discrepancy, replace (dispose of) the waste ink tank referring to  ["Replacing the Waste Ink Tank"\(P. 150\)](#).

7 Press the [ENTER] key to start air purging.

Air PG	
Air PG	
Start	[ENT]

8 Perform a test print and check the print results.

-  ["Test Printing"\(P. 87\)](#)

A large amount of a specific ink caused nozzle clogging

If a specific ink is causing a large number of nozzle clogging (dropouts), refill that ink individually. Note that this consumes a large amount of ink.

- 1 On the LOCAL mode screen, select [MENU] > [Maintenance], then press the [ENTER] key.
 - The Maintenance menu is displayed.
- 2 Select [FillUp Indiv. Ink] and press the [ENTER] key.
- 3 Press , then select [YES].

FillUp Indiv. Ink	
It will use a lot of ink.	
Execute ?	
NO <	> YES

- 4 Select the ink you want to use for refilling, then press the [ENTER] key.
 - Check the check box. Focus on filling the ink paths marked with a check mark.





- Ink that hasn't been checked will also be used up. Take care here.

Fill nozzle select	1/2
<input checked="" type="checkbox"/> M <input type="checkbox"/> C <input type="checkbox"/> Y <input type="checkbox"/> K <input type="checkbox"/> Lc	<div style="background-color: #003366; color: white; padding: 2px;">Fill nozzle select</div> <div style="text-align: right; padding: 2px;">2/2</div> <input type="checkbox"/> Lm <input type="checkbox"/> Wh <input type="checkbox"/> Wh
<< □ >>	<< □ >>

- 5 The "Check Waste Ink Tank" message appears on the display.

Check Waste Ink tank	
Level: xx %	

- 6 Check the waste ink levels in the waste ink tank.

- If there are discrepancies from actual levels, correct the waste ink amount.  ["When "Check Waste Ink Tank" message appears"\(P. 150\)](#)
- If there is no discrepancy, replace (dispose of) the waste ink tank referring to  ["Replacing the Waste Ink Tank"\(P. 150\)](#).

- 7 Press the [ENTER] key to start "Individual Ink Refill."

FillUp Indiv. Ink	
Start	[ENT]

- 8 Perform a test print and check the print results.

-  ["Test Printing"\(P. 87\)](#)

The ink has leaked out



- If an ink leak occurs, turn off the main power immediately and unplug the power cable. Then, contact your local dealer or our service office.

The light-blocking cover comes off.

If the light-blocking cover is left off, the ink inside the ink supply unit may be exposed to light and begin to harden.

If the light-blocking cover comes loose, reattach as follows:

- 1** Insert the lug on one side of the light-blocking cover into the corresponding hole in the tank.

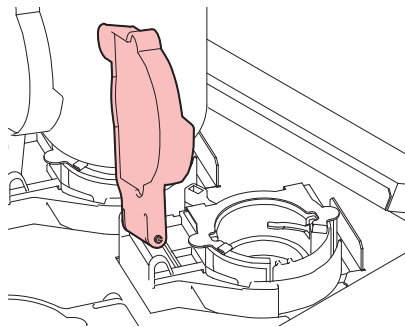

- 2** Insert the lug on the other side while pushing in toward the first hole in Step 1.

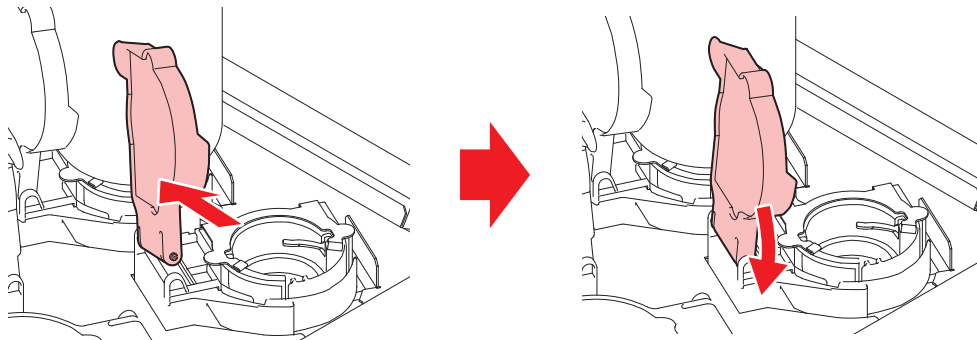

Abnormal noise occurs during cleaning

Cloth wiper may be entangled in the cloth wiper gear. Remove the cloth wiper and replace it.

Important!

- Perform the following procedure: Use the [Replace Wiper] menu to reset the wiper remaining amount.



- When handling **SPC-0919 or SPC-0932 cloth wipers**, be sure to wear safety glasses, gloves, and a mask. There is a risk of the liquid (solvent) contained in cloth wipers splashing and contacting your skin, eyes, or mouth.



- 1 On the LOCAL mode screen, select [MENU] > [Maintenance], then press the [ENTER] key.
 - The Maintenance menu is displayed.
- 2 Select [Station Maint.] > [Carriage Out] > [Move To Platen Right End], then press the [ENTER] key.
 - The carriage moves over the platen.
- 3 Open the maintenance cover on the right side.
- 4 Open the cloth wiper cover.
 - Push the two tabs at the front up to open.

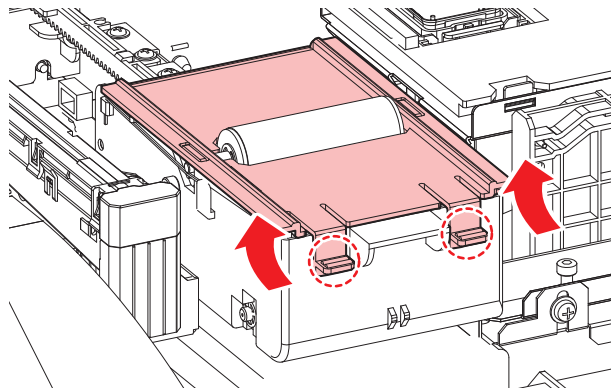

- 5 Remove the cloth wiper together with the spindle, then replace it.

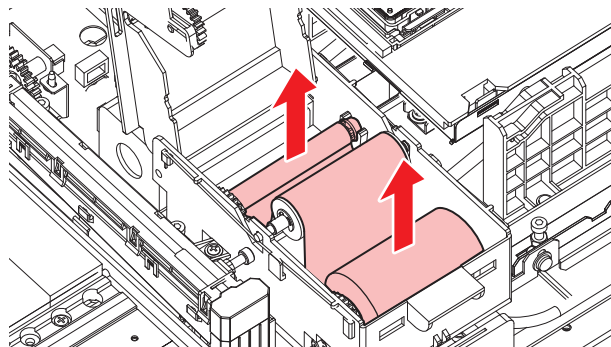

5.2 To Stop Circulation Operation

When white ink is installed, the ink is circulated periodically to prevent it from sedimenting. The procedure to stop circulation while the power is turned on is as follows:

- 1 Press the [END] key when [Preparing for circulation] or [Circulation] is displayed on the screen.

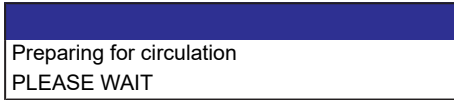

- 2 Use the ▲▼ keys to select [OK], then press the [ENTER] key.

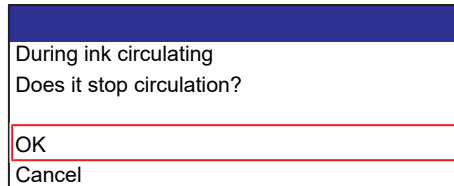

- The ink is automatically supplied and circulation stops.



- Ink circulation takes approximately 20 minutes.
- When circulation has been stopped, it will restart after a preset period of time has elapsed.

5.3 Problems Causing Messages to Appear

If a problem arises, the buzzer sounds and a message appears on the display.

You can also check the local guidance. Displaying Machine Information (Local Guidance)

Take the appropriate action in accordance with the content of the message. If a message reappears even after taking the prescribed action, contact your local dealer or our service office.

Warning Messages

Message	Cause	Corrective action
Replace NCU Ink Pad	<ul style="list-style-type: none"> The ink absorber needs to be replaced. 	<ul style="list-style-type: none"> The NCU ink absorber must be replaced. Contact your local distributor, our sales office, or service center.
Replace NCU	<ul style="list-style-type: none"> A problem was detected with the nozzle clogging assessment. 	<ul style="list-style-type: none"> Clean the NCU.  "NCU Cleaning"(P. 130) Replace the NCU if the error does not clear. Contact your local distributor, our sales office, or service center.
NCU Sensor Lv Low	<ul style="list-style-type: none"> The sensor's sensitivity is impaired. 	<ul style="list-style-type: none"> Clean the NCU.  "NCU Cleaning"(P. 130) Replace the NCU if the error does not clear. Contact your local distributor, our sales office, or service center.
NCU Sens Adj Err H	<ul style="list-style-type: none"> Sensor sensitivity adjustment failed. 	
NCU Sens Adj Err L		
NCU Connect	<ul style="list-style-type: none"> A problem was detected with the NCU connection. 	<ul style="list-style-type: none"> Turn off the power on the machine and turn it on after a while.
Ink Error	<ul style="list-style-type: none"> An ink error occurred. 	<ul style="list-style-type: none"> Check the ink error details.  "Ink Error"(P. 170)
COVER OPEN	<ul style="list-style-type: none"> The cover is open. 	<ul style="list-style-type: none"> Close the cover.
Data Remain	<ul style="list-style-type: none"> Print (RIP) data was received. 	<ul style="list-style-type: none"> Switch to REMOTE mode and start printing or clear the data and abort printing.
Temporary Suspension	<ul style="list-style-type: none"> Printing has been paused. 	<ul style="list-style-type: none"> Switch to REMOTE mode and resume printing or clear the data and abort printing.
Printing not possible/ink IC	<ul style="list-style-type: none"> An unusable ink IC chip is used. 	<ul style="list-style-type: none"> Replace with new ink and a new ink IC chip.  "Replacing Ink"(P. 50)
No Media	<ul style="list-style-type: none"> No media is loaded, or the sensors are faulty. 	<ul style="list-style-type: none"> Load the media.  "Loading the Media"(P. 62) Clean the media sensor.  "Media Sensor Cleaning"(P. 132)
Please load media	<ul style="list-style-type: none"> No media is loaded, or the sensors are faulty. 	<ul style="list-style-type: none"> Load the media.  "Loading the Media"(P. 62)
Media Undetected	<ul style="list-style-type: none"> The media width has not been detected. 	<ul style="list-style-type: none"> Detect the media width.  "Loading the Media"(P. 62)
Replace Wasteinktank	<ul style="list-style-type: none"> The waste ink tank count exceeded the preset value (90%). 	Automatic maintenance is not possible while the covers are open. Perform the following steps:

Message	Cause	Corrective action
		<ol style="list-style-type: none"> 1. Check the waste ink levels in the waste ink tank. "When "Check Waste Ink Tank" message appears"(P. 150) 2. Replace the waste ink tank, then reset the waste ink level. "Replacing the Waste Ink Tank"(P. 150)
Check Waste Ink tank	<ul style="list-style-type: none"> • The waste ink tank count exceeded the preset value (80%). 	<ol style="list-style-type: none"> 1. Check the waste ink levels in the waste ink tank. "When "Check Waste Ink Tank" message appears"(P. 150) 2. Replace the waste ink tank, then reset the waste ink level. "Replacing the Waste Ink Tank"(P. 150)
High ambient temp ** ° C	<ul style="list-style-type: none"> • Ambient temperatures are too high. 	<ul style="list-style-type: none"> • Adjust ambient temperatures to temperatures within the specified range. Optimum print quality may not be possible unless ambient conditions are within the specified range. "Installation Precautions"(P. 22)
Low ambient temp ** ° C	<ul style="list-style-type: none"> • Ambient temperatures are too low. 	
Auto-correction failed	<ul style="list-style-type: none"> • White media is not used. • The media is dirty. • The media lifts up. • There is dirt around the sensor. 	<ul style="list-style-type: none"> • Load white and clean media. • Load media so it does not lift up. • Clean the area around the sensor. "DAS (Automatic Correction Function) Sensor Cleaning"(P. 131) • If automatic correction fails repeatedly, correct the position manually. "Feed Correction"(P. 92) "Correcting the Drop Position"(P. 94)
Wiper End	<ul style="list-style-type: none"> • The cloth wiper has run out. 	<ul style="list-style-type: none"> • Replace with a new cloth wiper. "Cloth Wiper Replacement"(P. 142)
Wiper Near End	<ul style="list-style-type: none"> • The remaining amount of cloth wiper is low. 	<ul style="list-style-type: none"> • The ink will run out soon. Have a new cloth wiper ready. "Cloth Wiper Replacement"(P. 142)
Wiper Move Failure	<ul style="list-style-type: none"> • The wiper is not operating correctly. 	<ul style="list-style-type: none"> • Turn off the power on the machine and turn it on after a while.
Cleaning was executed because a large ambient temp. change was detected. Check the nozzle condition.	<ul style="list-style-type: none"> • A larger temperature change than expected (8 °C or more) was detected. • Cleaning was performed automatically when the power was turned on to protect the nozzle condition if a temperature changed after the power was turned off. 	<ul style="list-style-type: none"> • Perform a test print to check the nozzle state. "Test Printing"(P. 87)

Ink Error







Message	Cause	Corrective action
Ink End	<ul style="list-style-type: none"> • The ink has run out. 	<ul style="list-style-type: none"> • Replace with new ink. "When Ink End is Displayed"(P. 49) • If you use UISS, you may perform cleaning.





Message	Cause	Corrective action
Ink Near End	<ul style="list-style-type: none"> Ink levels are low. 	<ul style="list-style-type: none"> The ink will run out soon. Have new ink ready. "When Ink Near End is Displayed"(P. 49)
Non Ink IC	<ul style="list-style-type: none"> No ink IC chip was detected. 	<ol style="list-style-type: none"> Insert the ink IC chip. "Replacing Ink"(P. 50) Check to confirm the ink IC chip was inserted correctly. "Mounting the ink"(P. 54) Turn off the power on the machine and turn it on after a while.
Wrong Ink IC	<ul style="list-style-type: none"> An error occurred with the information on the ink IC chip. 	<ol style="list-style-type: none"> Check to confirm the ink IC chip was inserted correctly. "Mounting the ink"(P. 54) Turn off the power on the machine and turn it on after a while. Replace with new ink. "Replacing Ink"(P. 50)
Ink Color	<ul style="list-style-type: none"> The ink color registered on the IC chip is different from the ink color filled. 	<ul style="list-style-type: none"> Insert an ink IC chip for the correct ink color. "Mounting the ink"(P. 54)
Ink Type	<ul style="list-style-type: none"> The ink type registered on the IC chip is different from the ink type filled. 	<ul style="list-style-type: none"> Insert an ink IC chip for the correct ink type. "Mounting the ink"(P. 54)
Expiration Near	<ul style="list-style-type: none"> The ink has expired. 	<ul style="list-style-type: none"> Replace with new ink or use up as quickly as possible. Printing is possible. "When Ink End is Displayed"(P. 49)
Expiration Over	<ul style="list-style-type: none"> The ink is two months past its expiration date and cannot be used. 	<ul style="list-style-type: none"> Replace with new ink. Printing is not possible. "When Ink End is Displayed"(P. 49)





Error Message

Error number	Message	Cause	Corrective action
04	PARAM ROM	<ul style="list-style-type: none"> A problem was detected with the main PCB. 	<ul style="list-style-type: none"> Turn off the power on the machine and turn it on after a while.
108	HD THERMIS[12]	<ul style="list-style-type: none"> A problem was detected with print head temperature control. 	
108	HD CONNECT[12]	<ul style="list-style-type: none"> A problem was detected with the print head connection. 	
108	HD MEM EMP[12]	<ul style="list-style-type: none"> A problem was detected with the print head. 	
10e	FROM CLEAR	<ul style="list-style-type: none"> A problem was detected with the main PCB. 	
10f	FROM WRITE		
115	PCB MAIN-F1		
122	CHECK:SDRAM	<ul style="list-style-type: none"> A problem was detected with the SDRAM. 	
122	PRAM NONE		

Error number	Message	Cause	Corrective action
123	PRAM DATA	<ul style="list-style-type: none"> A problem was detected with the main PCB. 	
124	PRAM ADDR		
127	POWER OFF		
128	HDC FIFO OVER	<ul style="list-style-type: none"> A problem was detected with the print head control PCB. 	
128	HDC FIFO UNDER		
129	Battery Exchange	<ul style="list-style-type: none"> The internal clock battery is spent and must be replaced. 	<ul style="list-style-type: none"> Contact your local distributor, our sales office, or service center.
12a	HDC SPEED	<ul style="list-style-type: none"> A problem was detected with the print head control. 	<ul style="list-style-type: none"> Turn off the power on the machine and turn it on after a while.
12d	PCB MAIN-F4	<ul style="list-style-type: none"> A problem was detected with the main PCB. 	
130	HD DATA SEQ	<ul style="list-style-type: none"> A problem was detected with the print head control. 	
147	DS-IC BUSY	<ul style="list-style-type: none"> Ink IC control abnormality detected. 	
148	E-LOG SEQ	<ul style="list-style-type: none"> A log control abnormality was detected. 	
151	Main PCB V1R2	<ul style="list-style-type: none"> A problem was detected with the main PCB power supply circuit. 	
152	Main PCB V2R5		
153	Main PCB V3R3		
154	Main PCB V05		
155	Main PCB V42-1		
15f	HEAD DRIVE HOT	<ul style="list-style-type: none"> The HDCE PCB COM driver is hot. 	
171	NEW HEAD CONNECT	<ul style="list-style-type: none"> A new print head connection was detected. 	
186	HDC OVERFLOW/HDC UNDERFLOW	<ul style="list-style-type: none"> A problem was detected with the print head control. 	
187	HDC SLEW RATE		
188	HDC MEMORY		
189	COM VOLT[12]	<ul style="list-style-type: none"> A problem was detected with the HDCE PCB voltage. 	
18c	Main PCB V12	<ul style="list-style-type: none"> A problem was detected with the main PCB power supply. 	
18e	FLS NOT COMP	<ul style="list-style-type: none"> A problem was detected with the print head control. 	
18f	OFFSET START [12]		
18f	OFFSET END [12]		
19f	UV-LED Connect Error	<ul style="list-style-type: none"> The UV- LED PCB could not be detected. 	<ul style="list-style-type: none"> Turn off the power on the machine and turn it on after a while.

Error number	Message	Cause	Corrective action
1b5	SLIDER CONNECT	<ul style="list-style-type: none"> Unable to detect the HDCE PCB. 	<ul style="list-style-type: none"> Turn off the power on the machine and turn it on after a while.
1bf	PCB MAIN-F2	<ul style="list-style-type: none"> A problem was detected with the main PCB. 	
1d8	HEAD XHOT[12]	<ul style="list-style-type: none"> A problem was detected with the print head. 	
1e6	PRAM Size Shortage	<ul style="list-style-type: none"> Insufficient memory 	
201	Command Error	<ul style="list-style-type: none"> Data other than print (RIP) data was received, or a problem was detected with the print (RIP) data received. 	<ol style="list-style-type: none"> Clear the data and resend. Check the USB/Ether cable connection.  "Connecting a PC to the Product"(P. 44) Use a compatible cable.  "Connecting a PC to the Product"(P. 44) Turn off the power on the machine and turn it on after a while.
202	Parameter Error	<ul style="list-style-type: none"> A problem was detected with the print (RIP) data received. 	
206	Print Mode Error	<ul style="list-style-type: none"> Print (RIP) data was received with print parameters that do not allow printing. 	<ul style="list-style-type: none"> Change the output parameters and profile using RIP software.
20A	Driver Version	<ul style="list-style-type: none"> Printing is not possible because the Mimaki driver version is old. 	<ul style="list-style-type: none"> Install the latest Mimaki driver available from: https://mimaki.com/download/inkjet.html
303	PCB MAIN ET	<ul style="list-style-type: none"> A problem was detected with the main PCB. 	<ol style="list-style-type: none"> Turn off the power on the machine and turn it on after a while.
304	USB INIT ERR	<ul style="list-style-type: none"> A problem was detected with the USB cable connection. 	<ol style="list-style-type: none"> Check the USB cable connection.  "Using a USB Cable"(P. 45) Use a compatible cable.  "Using a USB Cable"(P. 45) Turn off the power on the machine and turn it on after a while.
305	USB TIME OUT		
318	SDcard Connection ERR	<ul style="list-style-type: none"> A problem was detected with the SD card. 	<ol style="list-style-type: none"> Turn off the power on the machine and turn it on after a while.
401	Motor X	<ul style="list-style-type: none"> The X motor was overloaded. 	<ol style="list-style-type: none"> Check to confirm the media is loaded correctly.  "Loading the Media"(P. 62) Open the front cover and check for anything that may obstruct carriage movement. Turn off the power on the machine and turn it on after a while.
402	Motor Y	<ul style="list-style-type: none"> The Y motor was overloaded. 	
403	X Current	<ul style="list-style-type: none"> An overcurrent error was detected in the X motor. 	
404	Y Current	<ul style="list-style-type: none"> An overcurrent error was detected in the Y motor. 	
406	Wiper Move Failure	<ul style="list-style-type: none"> The wiper origin could not be detected. 	<ul style="list-style-type: none"> Turn off the power on the machine and turn it on after a while.
44f	Take-up Roll Sns Err	<ul style="list-style-type: none"> A problem was detected with the take-up unit sensor spindle. 	<ol style="list-style-type: none"> Check to confirm the [Function Setting] > [Take-up Unit] setting is "ON". Check to confirm the media is loaded correctly.  "Loading the Roll Media"(P. 68)

Error number	Message	Cause	Corrective action
			3. Check to confirm the take-up unit switch functions properly.  "Take-up unit"(P. 64)
467	ZSTPOUT: 12	<ul style="list-style-type: none"> • Z-axis step-out was detected. 	<ul style="list-style-type: none"> • Turn off the power on the machine and turn it on after a while.
47f	Take-up Diameter Max	<ul style="list-style-type: none"> • The take-up unit media diameter has reached the maximum value. 	<ol style="list-style-type: none"> 1. Replace the paper core in the take-up unit.
48a	Detect winding failure	<ul style="list-style-type: none"> • A problem was detected with the take-up unit. 	<ol style="list-style-type: none"> 1. Check to confirm the [Function Setting] > [Take-up Unit] setting is "ON". 2. Check to confirm the media is loaded correctly.  "Loading the Roll Media"(P. 68) 3. Check to confirm the take-up unit switch functions properly.  "Take-up unit"(P. 64)
48b	Y MOTOR COM	<ul style="list-style-type: none"> • Y motor communication is not possible. 	<ul style="list-style-type: none"> • Turn off the power on the machine and turn it on after a while.
48c	Y MTR I2C COM	<ul style="list-style-type: none"> • Y motor communication is not possible at startup. 	
496	Y MOTOR DIR	<ul style="list-style-type: none"> • The Y motor operating direction cannot be specified. 	<ul style="list-style-type: none"> • Turn off the power on the machine and turn it on after a while.
4aa	Meander Adj. Roller Origin	<ul style="list-style-type: none"> • A problem was detected with meander adjustment roller origin detection (initialization). 	<ul style="list-style-type: none"> • Execute [Maintenance] > [Meander Recovery Action].
4ad	Meander Sensor Error	<ul style="list-style-type: none"> • A problem was detected with the meander control sensor. 	
4b0	Meander Limit Response	<ul style="list-style-type: none"> • A problem was detected with the meander control limit. 	
505	Media Jam	<ul style="list-style-type: none"> • The media jam sensor was triggered. 	<ol style="list-style-type: none"> 1. Remove the media in contact with the carriage and reload with fresh media.  "Media Sensor Cleaning"(P. 132) 2. Open the front cover and check for anything that may obstruct carriage movement.
509	HDC POSCNT	<ul style="list-style-type: none"> • A problem was detected with position control. 	<ul style="list-style-type: none"> • Turn off the power on the machine and turn it on after a while.
50a	Y Org Detect Error	<ul style="list-style-type: none"> • A problem was detected with Y origin detection (initialization). 	
50b	Front Edge Detect	<ul style="list-style-type: none"> • Rigid media front edge detection failed. 	<ul style="list-style-type: none"> • Clean the RGB color sensor.  "Media Sensor Cleaning"(P. 132) • Make sure the media is not slipping. • Depending on the media type and color, set the media detection method to "MANUAL".

Error number	Message	Cause	Corrective action
50c	Check Media With Sensor	<ul style="list-style-type: none"> A problem was detected with media width detection. 	<ol style="list-style-type: none"> Check the media loading position.  "Loading the Media"(P. 62) Clean the media width sensor.  "Media Sensor Cleaning"(P. 132)
50f	L-SCALE BLACK	<ul style="list-style-type: none"> A problem was detected with the linear scale. 	<ul style="list-style-type: none"> Turn off the power on the machine and turn it on after a while.
511	Z Org Detect Error	<ul style="list-style-type: none"> A problem was detected with Z origin detection (initialization). 	
515	Thickness Detection Error	<ul style="list-style-type: none"> A problem was detected with media thickness detection. 	
516	Media Set Position R (L)	<ul style="list-style-type: none"> The media was loaded outside the range of valid positions. 	<ol style="list-style-type: none"> Check the media loading position.  "Loading the Media"(P. 62) Clean the media width sensor.  "Media Sensor Cleaning"(P. 132)
525	Wrong Ionizer	<ul style="list-style-type: none"> The ionizer internal circuit is defective, or an abnormal discharge occurred. 	<ul style="list-style-type: none"> Turn off the power on the machine and turn it on after a while.
526	Ionizer Ion Level	<ul style="list-style-type: none"> The amount of generated ions was reduced by fouling and abrasion of the electrode needle. 	<ul style="list-style-type: none"> Refer to the instruction manual for the ionizer and clean the electrodes.
527	Ionizer Condition	<ul style="list-style-type: none"> Ambient conditions may cause ions to be absorbed by metals in the vicinity and affect discharge capability. 	<ul style="list-style-type: none"> Remove any conductors or discharge devices close to the ionizer.
528	Pump Motor	<ul style="list-style-type: none"> A problem was detected with the pump motor. 	<ul style="list-style-type: none"> Turn off the power on the machine and turn it on after a while.
549	LEnc. Count UVD	<ul style="list-style-type: none"> A problem was detected with the encoder input signal to the UVD32B PCB. 	<ul style="list-style-type: none"> Turn off the power on the machine and turn it on after a while.
54c	Vacuum Fan Err	<ul style="list-style-type: none"> A problem was detected with the vacuum fan. 	<ol style="list-style-type: none"> Make sure that the power cable is inserted into Inlet 2 and that the main power switch is turned ON. Turn off the power on the machine and turn it on after a while.
54d	HDCE Cooling Fan Err	<ul style="list-style-type: none"> An HDCE cooling fan rotation abnormality was detected. 	<ul style="list-style-type: none"> Turn off the power on the machine and turn it on after a while.
54e	UV-LED Fan Err	<ul style="list-style-type: none"> A UV-LED cooling fan rotation abnormality was detected. 	<ul style="list-style-type: none"> Turn off the power on the machine and turn it on after a while.
557	Obstacle Detection	<ul style="list-style-type: none"> An obstruction was detected. 	<ul style="list-style-type: none"> Remove any obstructions from on top of the media. Increase the head gap setting or media thickness setting to lower the media feeding belt height.

Error number	Message	Cause	Corrective action
56d	Positioning Bar Origin	<ul style="list-style-type: none"> A problem was detected with positioning bar origin detection (initialization). 	<ul style="list-style-type: none"> Turn off the power on the machine and turn it on after a while.
602	Ink End	<ul style="list-style-type: none"> The ink has run out. 	<ul style="list-style-type: none"> Replace with new ink. "When Ink End is Displayed"(P. 49)
604	Check Waste Ink tank	<ul style="list-style-type: none"> The waste ink tank count exceeded the preset value (80%). 	<ol style="list-style-type: none"> Check the waste ink levels in the waste ink tank. "When "Check Waste Ink Tank" message appears"(P. 150) Replace the waste ink tank, then reset the waste ink level. "Replacing the Waste Ink Tank"(P. 150)
608	Wrong Ink IC	<ul style="list-style-type: none"> An error occurred with the information on the ink IC chip. 	<ol style="list-style-type: none"> Check to confirm the ink IC chip was inserted correctly. "Mounting the ink"(P. 54) Turn off the power on the machine and turn it on after a while. Replace with new ink. "Replacing Ink"(P. 50)
60a	Excess Ink Usage	<ul style="list-style-type: none"> The ink usage amount stored in the ink IC chip exceeded the preset value. The ink IC chip was not replaced during ink replacement. (The same chip continued to be used.) The machine was used with nozzle clogging. 	<ul style="list-style-type: none"> Replace with new ink. "When Ink End is Displayed"(P. 49)
60c	Ink Type	<ul style="list-style-type: none"> The ink type registered on the IC chip is different from the ink type filled. 	<ul style="list-style-type: none"> Insert an ink IC chip for the correct ink type. "Mounting the ink"(P. 54)
61b	Ink supply	<ul style="list-style-type: none"> Ink cannot be supplied. 	<ol style="list-style-type: none"> Execute [Maintenance] > [Ink Supply Maint.]. ""(P. 114) If it persists even after this, contact your local dealer or our service office.
629	Expiration Near	<ul style="list-style-type: none"> The ink has expired. 	<ul style="list-style-type: none"> Replace with new ink or use up as quickly as possible. Printing is possible. "When Ink End is Displayed"(P. 49)
62a	Expiration Over	<ul style="list-style-type: none"> The ink is two months past its expiration date and cannot be used. 	<ul style="list-style-type: none"> Replace with new ink. Printing is not possible. "When Ink End is Displayed"(P. 49)
631	Ink Color	<ul style="list-style-type: none"> The ink color registered on the IC chip is different from the ink color filled. 	<ul style="list-style-type: none"> Insert an ink IC chip for the correct ink color. "Mounting the ink"(P. 54)
637	INK LEAK _	<ul style="list-style-type: none"> The ink leak sensor detected an ink leak. 	<ul style="list-style-type: none"> Contact your local distributor, our sales office, or service center.
650	NCU Connect	<ul style="list-style-type: none"> A problem was detected with the NCU connection. 	<ul style="list-style-type: none"> Turn off the power on the machine and turn it on after a while.

Error number	Message	Cause	Corrective action
651	Replace NCU	<ul style="list-style-type: none"> A problem was detected with the nozzle clogging assessment. 	<ul style="list-style-type: none"> Clean the NCU. 🛠️ "NCU Cleaning"(P. 130) Replace the NCU if the error does not clear. Contact your local distributor, our sales office, or service center.
652	NCU NzK Chk (Hw)	<ul style="list-style-type: none"> A problem was detected with the nozzle clogging assessment. 	<ul style="list-style-type: none"> Clean the NCU. 🛠️ "NCU Cleaning"(P. 130)
653	NCU NzK Chk (Mark)		
654	NCU Center Pos		
655	NCU Flush Pos		
656	NCU SN Adjst		
657	Replace NCU Ink Pad	<ul style="list-style-type: none"> The NCU ink absorber is full. 	<ul style="list-style-type: none"> The NCU ink absorber must be replaced. Contact your local distributor, our sales office, or service center.
658	NCU Sensor Lv Low	<ul style="list-style-type: none"> The sensor's sensitivity is impaired. 	<ul style="list-style-type: none"> Clean the NCU. 🛠️ "NCU Cleaning"(P. 130) Replace the NCU if the error does not clear. Contact your local distributor, our sales office, or service center.
65b	NCU Sens Adj Err H	<ul style="list-style-type: none"> Sensor sensitivity adjustment failed. 	<ul style="list-style-type: none"> Clean the NCU. 🛠️ "NCU Cleaning"(P. 130) Replace the NCU if the error does not clear. Contact your local distributor, our sales office, or service center.
65c	NCU Sens Adj Err L		
683	Wiper Near End	<ul style="list-style-type: none"> The remaining amount of cloth wiper is low. 	<ul style="list-style-type: none"> The cloth wiper will run out soon. Have a new cloth wiper ready.
684	Wiper End	<ul style="list-style-type: none"> The cloth wiper has run out. 	<ul style="list-style-type: none"> Replace with a new cloth wiper. Cloth Wiper Replacement
706	UV Lamp Temp. High	<ul style="list-style-type: none"> The UV-LED unit became hot. 	<ul style="list-style-type: none"> If this occurs frequently, contact your local distributor, our sales office, or service center.
707	Head Heater Break	<ul style="list-style-type: none"> The head heater is defective. (The temperature does not rise even when heated beyond the stipulated duration.) 	<ul style="list-style-type: none"> Turn off the power on the machine and turn it on after a while.
70b	DRV OVHT	<ul style="list-style-type: none"> The UV-DRV PCB became hot. 	
710	Heater Temp Error	<ul style="list-style-type: none"> A problem was detected with the heater temperature. 	<ul style="list-style-type: none"> This error will be automatically resolved. If the error is not resolved, turn off the main power and wait a while before turning back on.
711	LED OVHT*	<ul style="list-style-type: none"> The UV-LED PCB became hot. 	<ul style="list-style-type: none"> Turn off the power on the machine and turn it on after a while.

Error number	Message	Cause	Corrective action	
715	Ink Heater Therm Brk	<ul style="list-style-type: none"> The ink heater thermistor cannot be read properly. 		
716	Ink Heater Temp	<ul style="list-style-type: none"> An ink heater temperature abnormality was detected. 		
717	InkHeater Brk	<ul style="list-style-type: none"> The ink heater is defective. (The temperature does not rise even when heated beyond the stipulated duration.) 		
71a	UV-DRV Fuse	<ul style="list-style-type: none"> A blown fuse on the UV-DRV PCB was detected. 	<ul style="list-style-type: none"> The fuse must be replaced. Contact your local distributor, our sales office, or service center. 	
71e	Head Temp Error	<ul style="list-style-type: none"> A head temperature abnormality was detected. 	<ul style="list-style-type: none"> Turn off the power on the machine and turn it on after a while. 	
71f	Head Therm Break	<ul style="list-style-type: none"> The head thermistor cannot be read properly. 		
753	Ink Heater Temp (HW)	<ul style="list-style-type: none"> An ink heater temperature abnormality was detected. 	<ul style="list-style-type: none"> Turn off the power on the machine and turn it on after a while. 	
754	Ink Heater Temp	<ul style="list-style-type: none"> An ink heater temperature abnormality was detected for a specified time. 		
755	Head Temp Error (HW)	<ul style="list-style-type: none"> A head temperature abnormality was detected. 		
756	Head Temp Error	<ul style="list-style-type: none"> A head temperature abnormality was detected for a specified time. 		
801	(C) OPCODE	<ul style="list-style-type: none"> A problem was detected with the main PCB. 		<ul style="list-style-type: none"> Turn off the power on the machine and turn it on after a while.
802	(C) SWI			
803	(C)PFTCHABRT			
804	(C)DATAABRT			
806	FW/SIO bit	<ul style="list-style-type: none"> A communication error was detected between the boards. 		
808	FW/STP-MTR**	<ul style="list-style-type: none"> A problem was detected with the main PCB. 		
80f	FW/SIO Vch	<ul style="list-style-type: none"> A communication error was detected between the boards. 		
811	FW/SIO read	<ul style="list-style-type: none"> A communication error was detected between the boards. 		
81b	FW/STACK OV	<ul style="list-style-type: none"> A problem was detected with the main PCB. 	<ul style="list-style-type: none"> Check the error details. <ul style="list-style-type: none"> Media Undetected Ink Error Waste ink tank, etc. 	
828	PRG ERR L *****			
901	Operation Error	<ul style="list-style-type: none"> The function is disabled due to an error. 		

Error number	Message	Cause	Corrective action
902	Data Remain	<ul style="list-style-type: none"> Print (RIP) data was received. 	<ul style="list-style-type: none"> Switch to REMOTE mode and start printing or clear the data and abort printing.
90f	Print Area Short	<ul style="list-style-type: none"> The media is too small for the print. 	<ul style="list-style-type: none"> Replace with wider or longer media. If the printable area is reduced due to a shift in the origin, move the origin to increase the size of the printable area.
b1a	PCB BaseIO	<ul style="list-style-type: none"> A communication error was detected between the boards. 	<ul style="list-style-type: none"> Turn off the power on the machine and turn it on after a while.
b1b	BaseIO PCB Vpow-s	<ul style="list-style-type: none"> A problem was detected with the Base IO PCB power supply. 	
b1c	BaseIO PCB V24		
b1e	PCB BaseIO-F**	<ul style="list-style-type: none"> The Base IO PCB fuse blow was detected. 	<ul style="list-style-type: none"> The fuse must be replaced. Contact your local distributor, our sales office, or service center.
b36	PCB INKIO	<ul style="list-style-type: none"> A communication error was detected between the boards. 	<ul style="list-style-type: none"> Turn off the power on the machine and turn it on after a while.
b3f	BaseIO Unconform	<ul style="list-style-type: none"> The PCB could not be detected. 	
b42	PCB UVD32B	<ul style="list-style-type: none"> A communication error was detected between the boards. 	<ul style="list-style-type: none"> Turn off the power on the machine and turn it on after a while.
b46	PCB SubIO	<ul style="list-style-type: none"> A communication error was detected between the boards. 	
b47	UVD32B PCB Uvpow	<ul style="list-style-type: none"> A problem was detected with the UVD32B PCB power supply. 	
b48	PCB HDCE	<ul style="list-style-type: none"> A communication error was detected between the boards. 	<ul style="list-style-type: none"> Turn off the power on the machine and turn it on after a while.
b49	PCB HDCE-VHVFET[12]	<ul style="list-style-type: none"> A problem was detected with the HDCE PCB power supply. 	
b4a	PCB HDCE*-F*	<ul style="list-style-type: none"> A blown fuse on the HDCE PCB was detected. 	<ul style="list-style-type: none"> Contact your local distributor, our sales office, or service center.
b4b	HDCE* PCB V1R2	<ul style="list-style-type: none"> A problem was detected with the HDCE PCB power supply. 	<ul style="list-style-type: none"> Turn off the power on the machine and turn it on after a while.
b4c	HDCE* PCB V2R5		
b4d	HDCE* PCB V3R3		
b4e	PCB SubIO-F*	<ul style="list-style-type: none"> A blown fuse on the SubIO PCB was detected. 	<ul style="list-style-type: none"> The fuse must be replaced. Contact your local distributor, our sales office, or service center.
b4f	SubIO PCB Vpow-s	<ul style="list-style-type: none"> A problem was detected with the SubIO PCB power supply. 	<ul style="list-style-type: none"> Turn off the power on the machine and turn it on after a while.

Error number	Message	Cause	Corrective action
b50	SubIO PCB FANPOW	<ul style="list-style-type: none"> A problem was detected with the SubIO PCB power supply. 	
b51	BaseIO PCB V24adj	<ul style="list-style-type: none"> A problem was detected with the Base IO PCB power supply. 	<ul style="list-style-type: none"> Turn off the power on the machine and turn it on after a while.
b54	PCB INKIO-F*	<ul style="list-style-type: none"> A blown fuse on the ink PCB was detected. 	<ul style="list-style-type: none"> The fuse must be replaced. Contact your local distributor, our sales office, or service center.
b1f	PCB HDCE*	<ul style="list-style-type: none"> A communication error was detected between the boards. 	<ul style="list-style-type: none"> Turn off the power on the machine and turn it on after a while.
b2f	PCB HDCE*-F*	<ul style="list-style-type: none"> A blown fuse on the HDCE PCB was detected. 	<ul style="list-style-type: none"> The fuse must be replaced. Contact your local distributor, our sales office, or service center.
c36	Mark Detect	<ul style="list-style-type: none"> Unable to detect register marks 	<ol style="list-style-type: none"> Load the uncurled media. Check the mark detection start position. Check to confirm the register marks are black and printed on a white background. Check to confirm the area between the register marks is clean and free of print. When using clear media, set the solid register marks.

SYSTEM HALT



- If a SYSTEM HALT number is displayed, Turn off the power on the machine and turn it on after a while.

Chapter 6 Appendix



This chapter

This chapter describes the machine specifications.

Specifications	182	LICENSE Library	196
Options	186		
Options List	186		
Ionizer	186		
Roller Table Assy	189		

6.1 Specifications

Item		Specifications	
Print head	Type	On-demand piezo head	
	Specifications	Two staggered heads with 400 nozzles × 8 rows each	
	Resolution	Y 600 dpi, 1,200 dpi X 600 dpi, 900 dpi, 1,200 dpi, 1,800 dpi	
Ink Type		ELS-170/175, LUS-210	
Ink set	4-color	C, M, Y, K	
	6-color, W	C, M, Y, K, Lc, Lm, W	
	4-color, W, Cl	C, M, Y, K, W, Cl	
	4-color, W	C, M, Y, K, W	
Roll media	Type	Label paper (paper base), PVC sheet (not more than 0.25 mm in thickness, including laminating layer), fluorescent sheet, reflective sheet (excluding high-luminosity reflective sheet), window film, tarpaulin, flexible packaging film	
	Maximum printing width	1,610 mm	
	Maximum width	1,620 mm	
	Minimum width	210 mm	
	Thickness	Max. 50.8 mm	
	Roll external diameter	Feed side	250 mm
		Take-up side	Max. 250 mm, or max. 200 mm when using media edge guides ^{*1}
	Roll weight	Feed side	Max. 45 kg per roll ^{*2}
		Take-up side	Max. 45 kg per roll ^{*2}
	Paper core internal diameter ^{*3}	2 inches or 3 inches	
	Printing face	Exterior/interior	
	Roll end	Taped or loosely affixed to paper core	
	Print margins	Left/right	15 mm (default), minimum: Left/right 5 mm
Top end		70 mm (default), minimum: Left/right 10 mm	
Bottom end		70 mm (default), minimum: Left/right 10 mm	
Rigid media	Media thickness	Max. 50.8 mm	
	Media weight	Max. 7 kg/m ²	
	Z vertical range	52.3 mm (media thickness + head gap variation)	
	Multiple sheet printing capability	Up to 3 sheets	
	Maximum printing width	1,610 mm	
	Maximum width	1,620 mm	
	Minimum width	210 mm	

Item		Specifications
Print margins	Left/right	15 mm (default), minimum: 5 mm
	Front-rear edges	Fixed value: 5 mm
	Space between data	70 mm (default), minimum: 10 mm
Frame for borderless printing* 4		A frame larger than the media size + 5 mm on the left, right, front, and rear (print margin) is required.
Settable media length		280 mm~ 2,500mm(Print length: 270 mm to 2,490 mm) Printer control constraint: 280 mm~ 3,100mm (Print length: 270 mm to 3,090 mm)
		Physically settable length: For main unit only: Up to 450 mm ^{*5} When using one Roller Table Assy: Up to 1,300 mm When using two Roller Table Assy: Up to 2,500 mm When using three Roller Table Assy: Up to 3,100 mm
Distance accuracy ^{*6}	Absolute accuracy	±0.3 mm or ±0.3 % of specified distance, whichever is greater
	Duplicability	±0.2 mm or ±0.1 % of specified distance, whichever is greater
Perpendicularity		±0.25 mm/1,000 mm
Media skew		Not more than 2.5 mm/10 m
Printing gap		Gap between nozzle and media: 1.5 mm to 3.0 mm (in +0.1 mm intervals), belt moves up and down automatically
Origin alignment		LED pointer
Ink supply		Ink bottle
Waste Ink Tank		Bottle type (2,000 ml)
Take-up unit		Selectable inside/outside winding
NCU (Nozzle clogging detection)		Provided
DAS (Automatic correction function)		Provided
Interior lighting		Provided
UV unit		Air-cooled LED UV emitters x2
Interface	Data transfer function	Ethernet 1000BASE-T (recommended) ^{*7, 8} , USB 2.0 Hi-speed ^{*8, 9}
Command		MRL-V
Languages		English, Japanese, Chinese, Turkish, Portuguese, Spanish, Italian, Korean
Noise levels	During standby	Not more than 54 dB (FAST-A, 1 m on all sides)
	Continuous operation	Not more than 74 dB (FAST-A, 1 m on all sides)
	Non-continuous operation	Not more than 74 dB (FAST-A, 1 m on all sides)
Compliance with standards		VCCI Class A, FCC Class A, IEC 62368-1 ETL compliance, CE marking (EMC Directive, Low Voltage Directive, Machinery Directive, RoHS Directive), CB certified, REACH, EnergyStar, RCM marking, KC certified, UKCA marking

Item		Specifications	
Power supply specifications ^{*10}		Single-phase 100 to 120 V AC $\pm 10\%$ /8 A, single-phase 200 to 240 V AC $\pm 10\%$ /4 A, 50/60 Hz ± 1 Hz $\times 2$	
Power consumption	Maximum ^{*11}	Inlet 1	100 to 120 V AC: Max. 800 W 200 to 240 V AC: Max. 800 W
		Inlet 2	100 to 120 V AC: Max. 800 W 200 to 240 V AC: Max. 800 W
	Standard	Inlet 1	400 W
		Inlet 2	500 W
	Minimum ^{*12}	Inlet 1	4.5 W or less
		Inlet 2	4.5 W or less
Installation environment ^{*13}	Permissible ambient temperature		20 to 30 °C
	Relative humidity		35 to 65 %RH (no condensation)
	Temperature range in which accuracy is guaranteed		20 to 25 °C
	Temperature gradient		Not more than ± 10 °C/h
	Dust		0.15 mg/m ³ (typical office)
	Maximum operating altitude		2,000 m
External dimensions ^{*14}	Width		3,225 mm (3,580 mm)
	Depth ^{*15}		785 mm (1,020 mm)
	Height		1,420 mm ^{*16} (1,090 mm)



Item	Specifications
Weight ^{*14,*15,*17}	386 kg (486 kg)

- *1. Maximum roll diameter including slack caused by the outer diameter of the media after printing and the take-up tension.
- *2. However, there must be no feeding issues due to sagging under weight when the roll is supported at both ends.
- *3. 3 inch only for high-speed printing.
- *4. When printing without edge margins, prepare and use a frame-type jig.
- *5. Depending on the printing conditions, the Roller Table Assy may be required. Refer to  "Loading Rigid Media"(P. 72) for details.
- *6. Excluding media size variation and initial loading fluctuations.
- *7. Printing is not possible if local guidance shows any speed other than "1000Mbps". Using a LAN Cable
- *8. The print speed may be decreased depending on the connection environment or print data. Connecting a PC to the Product
- *9. Data may be transferred to the machine too slowly, causing the carriage to pause at the left-hand or right-hand end during printing.
- *10. Excluding options.
- *11. Varies depending on print mode.
- *12. In sleep.
- *13. If the installation environment does not satisfy the requirements, there is a risk of poor ink ejection consistency or media transport stability. In particular, when performing high-density printing on roll media at low ambient temperatures, the media may lift up (wrinkles) due to shrinkage.
- *14. The figures in parentheses indicate package dimensions.
- *15. 2,664 mm when using one Roller Table Assy, 4,712 mm when using two Roller Table Assys
- *16. Excluding the ink bottles.
- *17. Plus additional 112 kg when using one Roller Table Assy, plus additional 224 kg when using two Roller Table Assys

6.2 Options

● Compatibility table

Options List

Name		Code	Remarks/Reference page
Ionizer	Ionizer main unit	OPT-J0545	Same as for 330 Series  "Ionizer"(P. 186)
	Ionizer connection kit	OPT-01024	 "Ionizer"(P. 186)
Roller Table Assy		OPT-01020	 "Roller Table Assy"(P. 189)

Ionizer



Be sure to read and understand the following information before use.

● Before use

- May not be sufficiently effective in removing static electricity in certain environments or for certain media.
- We recommend checking to ensure that static electricity has been sufficiently removed before use.



- Make sure you fully understand the following details. The same precautions apply to optional items.

- (1)  "Introduction"(P. 6)
- (2)  "To Ensure Safe Use"(P. 8)
- (3)  "Installation Precautions"(P. 22)



- This is a high-voltage device. Avoid exposure to substances such as water, oil, or flammable solvents. Failure to follow this precaution may cause insulation breakdown and pose a risk of mechanical failure or electric shock.



- Keep metal objects and body parts such as face and hands away from the ionizer. This may pose a risk of failure or electric shock.
- Always use ventilation. If the ionizer is used in an enclosed area, the ozone generated may be harmful.
- Do not touch the electrode probes with tools or other hard objects. This may pose a risk of failure or electric shock.
- Clean periodically. As the ionizer is used, dust, ink, and the like will adhere to the electrode probes. Continuing to use the ionizer in this state may make it less effective at removing static electricity and may result in failure or electric shock.
- Never attempt to repair the machine yourself, which is hazardous. This may pose a risk of failure or electric shock. In case of abnormalities, contact your local dealer or our service office.



- Do not use where the temperature may change suddenly or where condensation may occur.
- Do not use for purposes other than removing static electricity.



- Be careful not to touch the electrode probes. There is a risk of injury from the tips, which are sharp.

Using the Ionizer

● Enable use of the ionizer

- 1 On the LOCAL mode screen, select [MENU] > [Function Setting], then press the [ENTER] key.
 - The Function Setting menu is displayed.
- 2 Select [Ionizer] > [ON], then press the [ENTER] key.

● How to use

- 1 Load the media.  ["Loading the Media"\(P. 62\)](#)



- Be careful not to touch the electrode probes when loading the media. Note particularly that the electrode probes are live when loading rigid media. Take care not to insert your hands inside the machine when inserting rigid media from the rear of the machine.

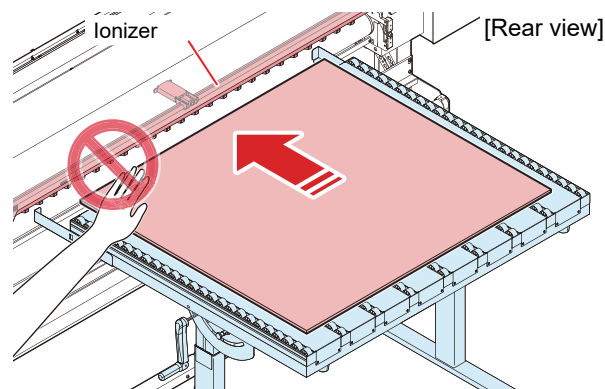

- 2 Print.

- Turn on the static removal function to remove static from the media while printing.

● Maintenance

Before printing, examine the electrode probes and clean off any dirt.



- Turn off the main power supply and unplug the power cable before carrying out maintenance.

- 1 Restart the machine, then lower the media feeding belt to the origin position.

- 2 Remove the electrode probes from the ionizer.

- Using the included replacement kit enables easy removal.

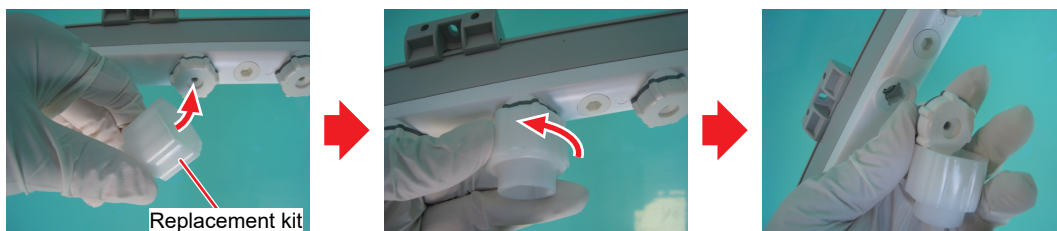

3 Wipe off the electrode probes and the area around them with a cotton swab soaked in alcohol.

- Recommended: Ethyl alcohol, isopropyl alcohol



- Use an ultrasonic bath if especially dirty. Industrial alcohol can also be used as a cleaning solution.



- After cleaning, dry well before reattaching to the ionizer. Any liquid remaining on the probes may cause failure or electric shock.

Ionizer indicator light (alarm function)

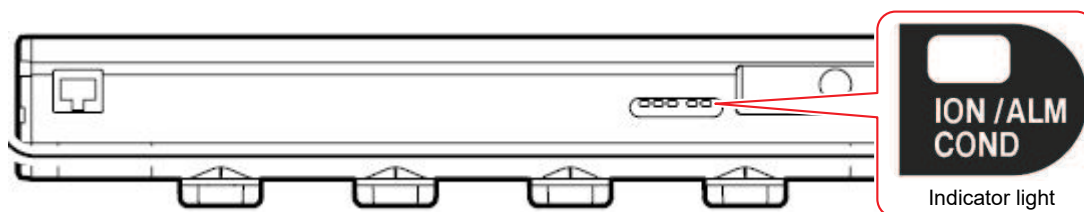

Indicator light	Ionizing status	Error display	Cause	Corrective action
Flashes three times every second	Stopped	Error 525 Wrong Ionizer	<ul style="list-style-type: none"> • Defective internal circuit. • Abnormal electrical discharge. 	<ul style="list-style-type: none"> • Contact your local dealer or our service office.
Flashes about twice per second	Continuous	Error 526 Ionizer Ion Level	<ul style="list-style-type: none"> • Lower ion generation due to fouling or abrasion of the electrode probes. • This is a sign that electrode probe cleaning is needed. 	<ul style="list-style-type: none"> • Clean the electrode probes. • If the problems persist, replace the corresponding probes. <ul style="list-style-type: none"> – SPA-0208 replacement tungsten probes for ionizer (includes 4)
Flashes about once per second	Continuous	Error 527 Ionizer Condition	<ul style="list-style-type: none"> • Removal of static electricity has been affected by the installation environment (temperature, humidity, nearby metal, etc.). 	<ul style="list-style-type: none"> • Investigate the environment and nearby metal.

Roller Table Assy

Be sure to read and understand the following information before use.

● Roller Table Assy specifications

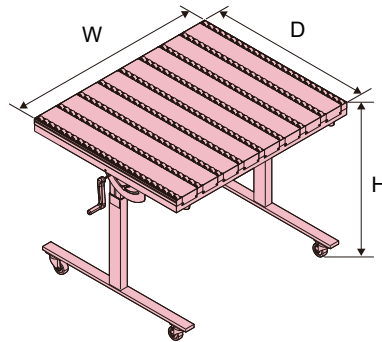

Item		Specifications
External dimensions	W	1,223 mm
	D	1,024 mm
	H ^{*1}	1,033 mm (823 mm)
Packaged dimensions ^{*2}	W	1,322 mm (1,350 mm)
	D	1,154 mm (1,200 mm)
	H	279 mm (700 mm)
Weight		56 kg
Packaged weight ^{*3}		71 g (155 kg)
Load capacity		25 kg
Installation environment ambient conditions	Temp.	20 to 30 °C
	Humidity	35 to 65 %RH

*1. Roller Table Assy maximum height. Figure in parentheses indicates minimum height.

*2. Dimension for one set in one box. Not including pallet. Figure in parentheses indicates packaged dimension for one set in two boxes and pallet.

*3. Weight for one set in one box. Not including pallet. Figure in parentheses indicates packaged weight for one set in two boxes and pallet.

● Operating procedure



- If the media is less than 1,300 mm long, use two Roller Table Assys with one each at the front and rear of the machine. 📖 ["When using one set of Roller Table Assy"\(P. 190\)](#)
- If the media is 1,300 mm or longer, use four Roller Table Assys with two each at the front and rear of the machine. 📖 ["When using two or more Roller Table Assys"\(P. 192\)](#)

Install the Roller Table Assys in accordance with the nameplates affixed to them.

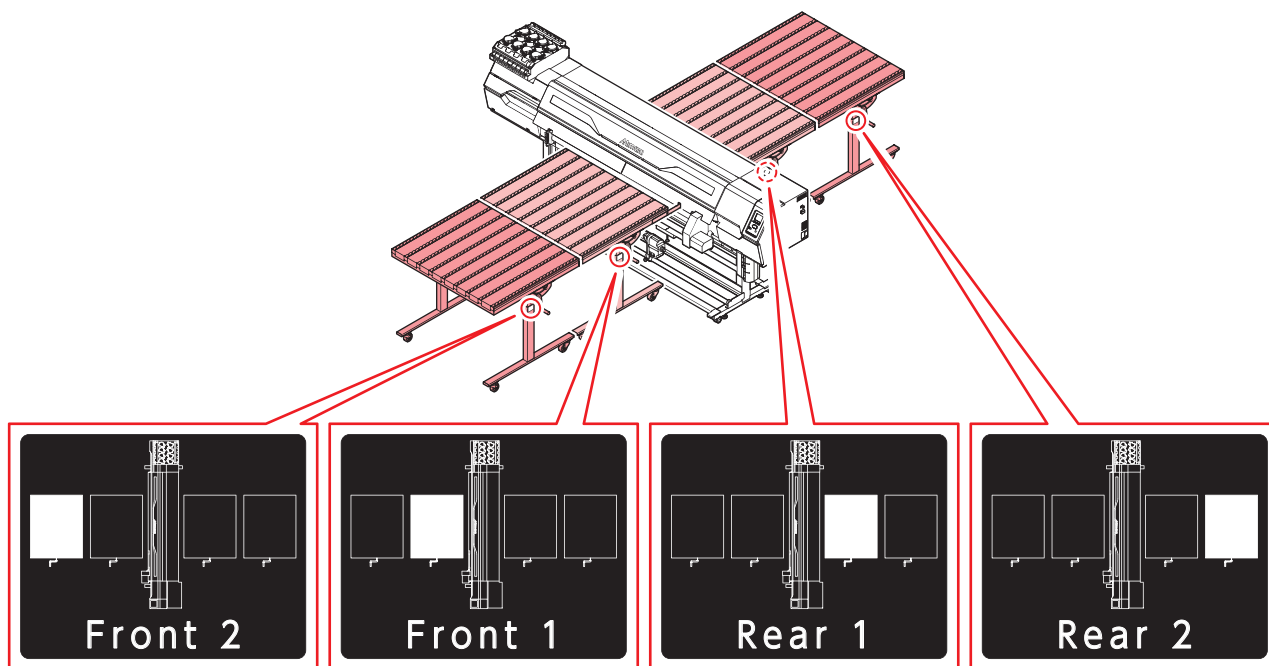

Important!

- When installing the Roller Table Assys, a service technician will adjust the level of each Roller Table Assy to suit the installation location. Be sure to install the Roller Table Assys in the positions indicated on the nameplates affixed to them.

When using one set of Roller Table Assy

1 Install the Roller Table Assy at the center of the machine.

- Press the ends of the Roller Table Assy legs up against the positioning bars. Align the ends of the Roller Table Assy legs with the nameplates on the positioning bar here.

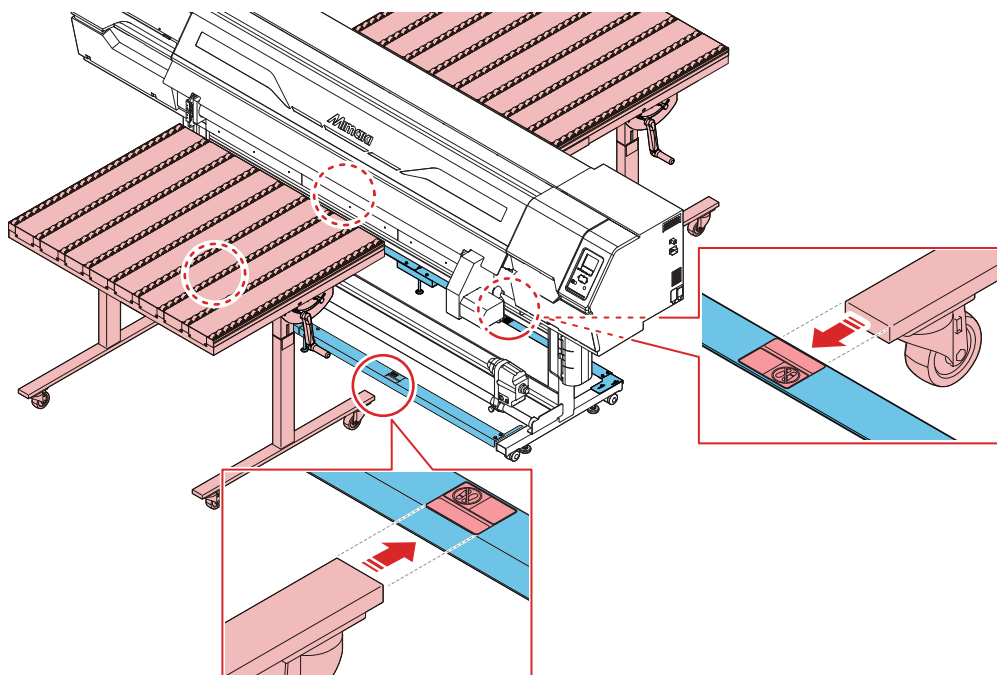

2 Lock the four casters on each Roller Table Assy to prevent them from moving.

- 3** Press the magnet on the anti-static ground cable against the underside of the machine main unit frame.

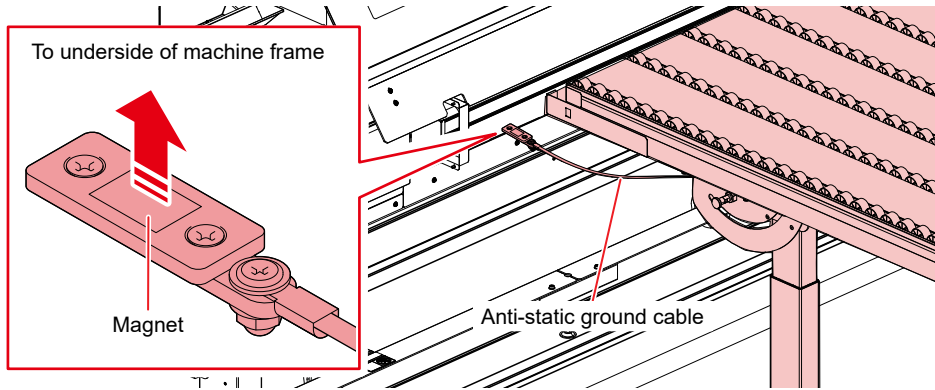

- If it is not pressed firmly against the frame, there is a possibility of ejection failures and other problems due to discharge from the Roller Table Assy. There is also a risk of injury.

- 4** Adjust the height of the Roller Table Assy.

- When viewed from the side, the height of the top of the Roller Table Assy rollers should be the same as the height of the machine belt.
- Adjust the height by turning the handle on the side of each Roller Table Assy.

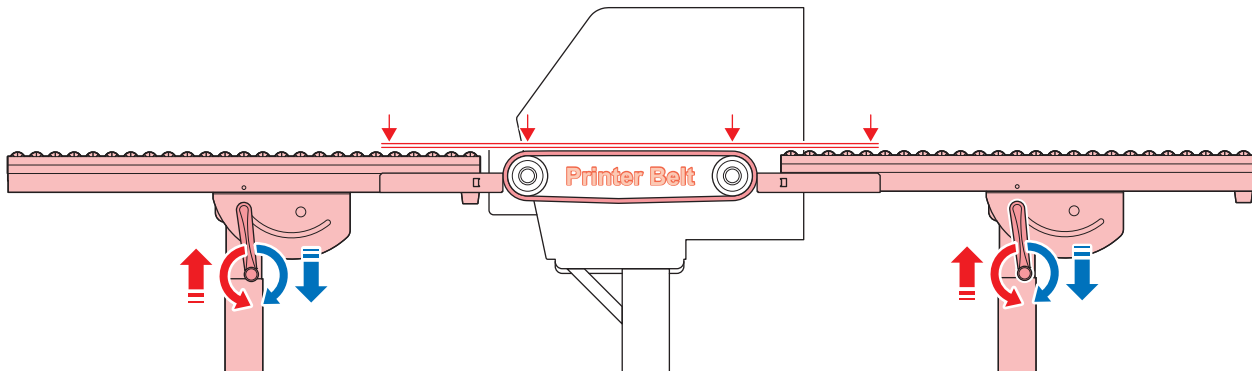

- 5** Place the media on top of the Roller Table Assy and machine belt, and check to confirm that it does not lift up off the belt.

When using two or more Roller Table Assys

1 Install the Roller Table Assy at the center of the machine.

- Press the ends of the Roller Table Assy legs up against the positioning bars. Align the ends of the Roller Table Assy legs with the nameplates on the positioning bar here.

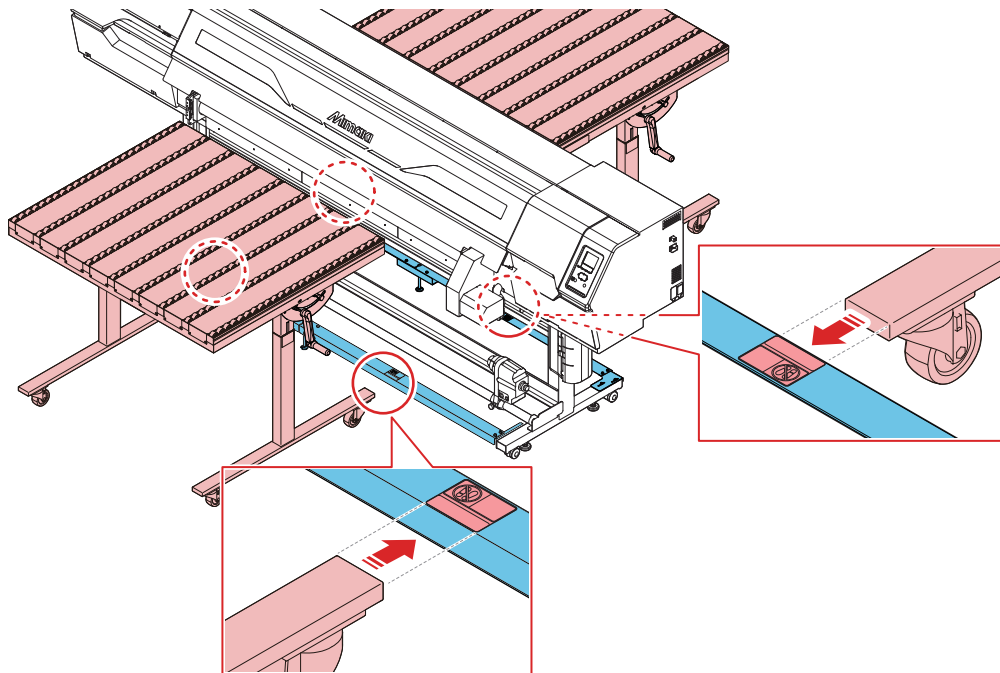

2 Lock the four casters on each Roller Table Assy to prevent them from moving.

3 Install the outer Roller Table Assy.

- Install so that there is no gap between the Roller Table Assys next to the printer and the outer Roller Table Assy.
- If you are using three sets of transport platforms, set them up in the same way as the second set.

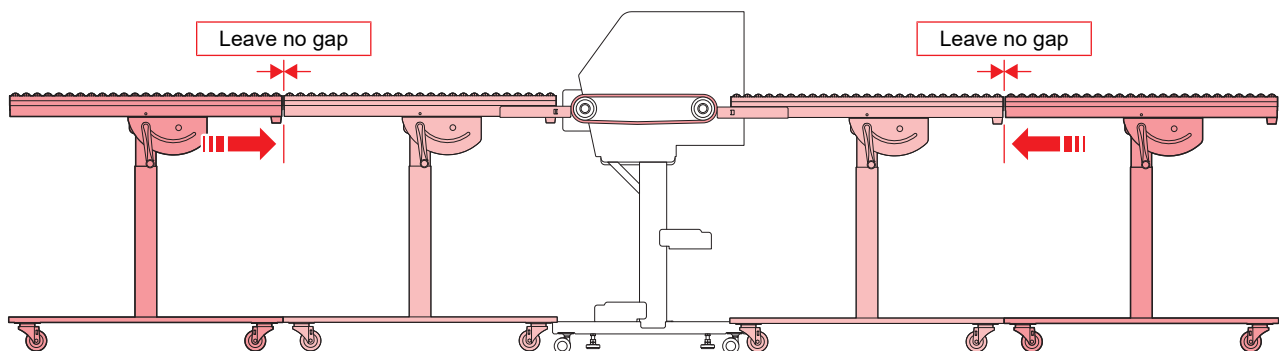

4 Press the magnet on the anti-static ground cable against the underside of the machine main unit frame (or Roller Table Assy).

- With the inner Roller Table Assy, press the magnet against the underside of the printer main unit frame.

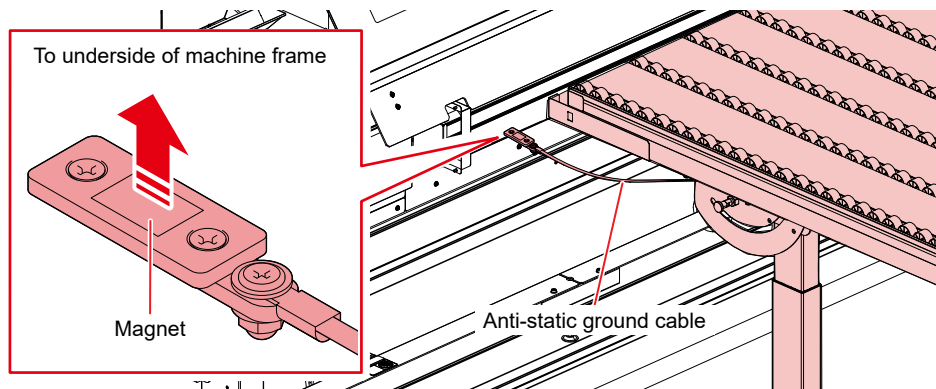

- With the outer Roller Table Assy
S/N:XA61M001 ~ XA62M060: press the magnet against the metal part of the rail on the inner Roller Table Assy.
S/N:XA62M061 and later: Attach it to the metal section of the beam beneath the inner Roller Table Assy., as the side surfaces are covered with covers

Outer Roller Table Assy

S/N:XA61M001 ~ XA62M060

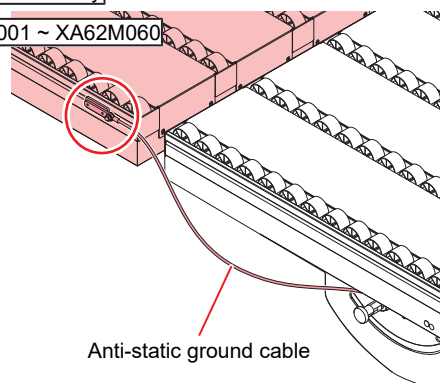

Anti-static ground cable

S/N:XA62M061 and later

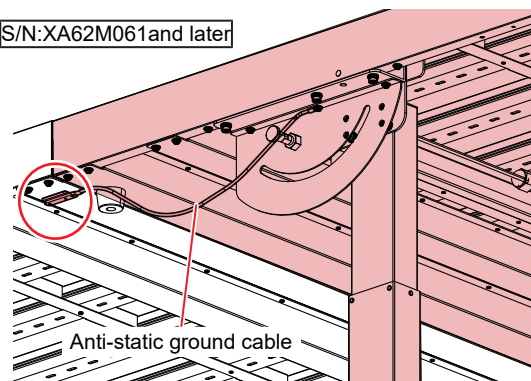

Anti-static ground cable



- When using two or more sets of Roller Table Assys, the outer Roller Table Assys have different attachment points for the anti-static grounding cable with serial numbers XA61M001 through XA62M060 and those with serial numbers XA62M061 and above. Check the serial number before attaching.



- If it is not pressed firmly against the frame, there is a possibility of ejection failures and other problems due to discharge from the Roller Table Assy. There is also a risk of injury.

5 Adjust the height of the Roller Table Assy.

- When viewed from the side, the height of the top of the Roller Table Assy rollers should be the same as the height of the machine belt.
- Adjust the height by turning the handle on the side of each Roller Table Assy.
- Check to confirm that the adjacent Roller Table Assys are at the same height (both front and rear).

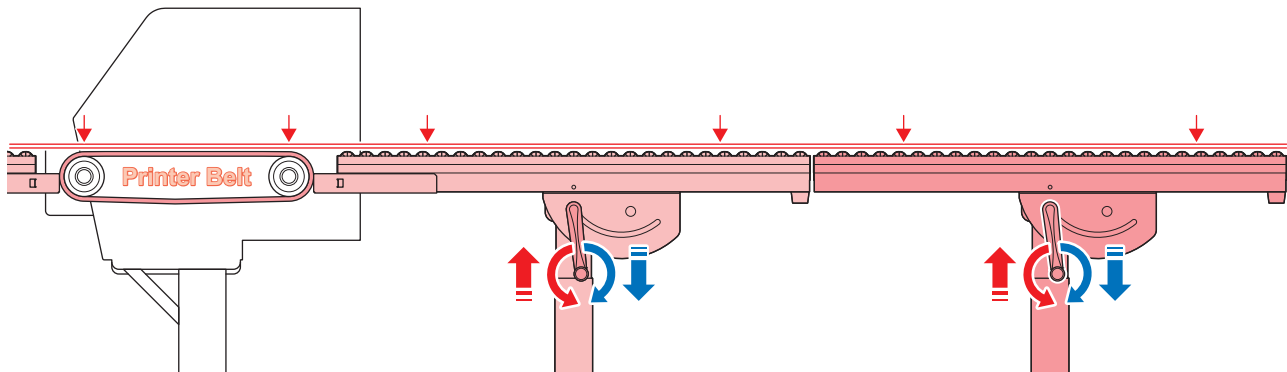

6 Place the media on top of the Roller Table Assy and machine belt, and check to confirm that it does not lift up off the belt.

When the Roller Table Assys are not used



- The Roller Table Assys can be folded up. When not in use, they can be folded up and stored.

● Procedure

1 Release the left and right locking index plungers, then slowly fold the Roller Table Assy until the table surface is vertical.

- Pulling the plunger knobs and rotating 90° locks the pins in the retracted position.

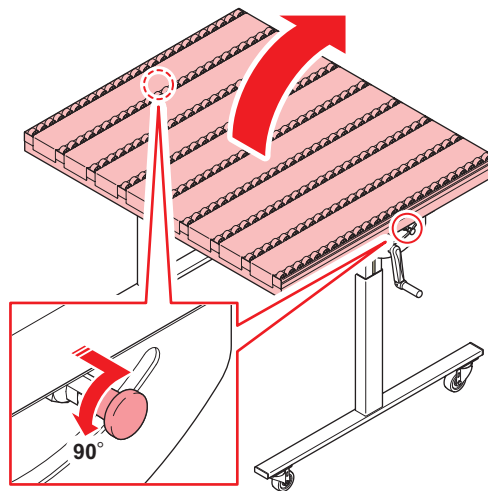

- Be careful to avoid trapping your hands here.

2 Once the table is folded up, push the plungers back in to lock them.

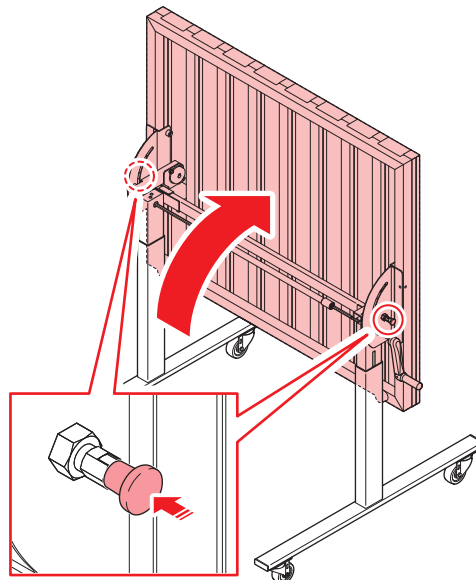

- When returning the Roller Table Assy to the horizontal position for use, be careful to avoid hitting your head or body with the table. Also be careful to avoid trapping your hands.



- To release the plunger locks, pull the knobs slightly and rotate them 90°.
- If the plunger locks are difficult to release (if they do not move when pulled), they can be released by pulling the knobs while tilting the table.

6.3 LICENSE Library

Mimaki printer Firmware

Copyright ©2020 MIMAKI ENGINEERING CO.,LTD. All rights reserved.

This product contain open source software listed in the tables below.

Component	License
StarterWare for ARM® based TI Sitara Processors	BSD-TI

The following license terms and conditions shall apply to the open source software listed in the table above:

BSD-TI

Copyright (C) 2010 Texas Instruments Incorporated - <http://www.ti.com/>

Redistribution and use in source and binary forms, with or without modification, are permitted provided that the following conditions are met:

1. Redistributions of source code must retain the above copyright notice, this list of conditions and the following disclaimer.
2. Redistributions in binary form must reproduce the above copyright notice, this list of conditions and the following disclaimer in the documentation and/or other materials provided with the distribution.
3. Neither the name of Texas Instruments Incorporated nor the names of its contributors may be used to endorse or promote products derived from this software without specific prior written permission.

THIS SOFTWARE IS PROVIDED BY THE COPYRIGHT HOLDERS AND CONTRIBUTORS "AS IS" AND ANY EXPRESS OR IMPLIED WARRANTIES, INCLUDING, BUT NOT LIMITED TO, THE IMPLIED WARRANTIES OF MERCHANTABILITY AND FITNESS FOR A PARTICULAR PURPOSE ARE DISCLAIMED. IN NO EVENT SHALL THE COPYRIGHT OWNER OR CONTRIBUTORS BE LIABLE FOR ANY DIRECT, INDIRECT, INCIDENTAL, SPECIAL, EXEMPLARY, OR CONSEQUENTIAL DAMAGES (INCLUDING, BUT NOT LIMITED TO, PROCUREMENT OF SUBSTITUTE GOODS OR SERVICES; LOSS OF USE, DATA, OR PROFITS; OR BUSINESS INTERRUPTION) HOWEVER CAUSED AND ON ANY THEORY OF LIABILITY, WHETHER IN CONTRACT, STRICT LIABILITY, OR TORT (INCLUDING NEGLIGENCE OR OTHERWISE) ARISING IN ANY WAY OUT OF THE USE OF THIS SOFTWARE, EVEN IF ADVISED OF THE POSSIBILITY OF SUCH DAMAGE.

Index

Icons

Auto Vacuum Fan Stop	110
Cap Suction Check.....	114
FillUp Indiv. Ink.....	114, 164, 165

A

Adjust Waste Ink Volume	150
Air PG.....	89, 114, 164
Auto Cleaning	113
Auto Maint.	30, 31, 113
Auto Media Eject	110
Auto Nozzle Recovery	113
Auto Power-off.....	118
Auto Power-on.....	118
Auto Remote	119
Auto-correction (DAS)	108, 170

B

Bottle cap	51, 52, 53
------------------	------------

C

Cancel	38
Cap.....	35, 125, 127, 146
Cap absorber.....	148
Cap Replacement.....	112, 122
Capping Use Days	122
Carriage.....	30, 35, 38, 112, 125, 127
Carriage Out.....	112
Cleaning	89, 112
Cloth wiper	125
Color profile	47
Custody Wash	112, 139

D

DAS (Dot Adjustment System)	108, 125, 131
Delete MediaInfo	111
Detail Setting	110
DISCLAIMERS	6
Display.....	38

Display language	120
Drop.PosCorrect.....	40, 59, 94, 108
Dropouts	89, 114, 164, 165

E

Ejection failures	87, 89, 112, 114, 129, 146, 158
[END/POWER] key.....	37, 38, 42
[ENTER] key.....	38
Environment Setting Menu	120
Error.....	38, 169
Error History	122

F

FCC	7
Feed Comp.....	40, 59, 92, 108
Feed Comp.(pull-back).....	108
Feed Speed	110
Feeding unit.....	32
FillUp Individ. Ink.....	89
Front cover	31
[FUNCTION] key	38, 40
Function Setting Menu	118

H

Head Cleaning.....	38
Head height	60, 109
Heater.....	37
High Power	89

I

Illumination	119
Ink bottle	34, 50, 52, 54
Ink caps	50
Ink discharge channel	125, 132
Ink End	49
Ink Error.....	39
Ink IC chip	34, 51, 54, 55
Ink IC chip slot.....	34, 54
Ink lever.....	34
INK NEAR-END.....	49
Ink replacement.....	122
Ink status	39

Ink Supply Error.....	114
Ink Supply Maint.....	114
Ink wipe pad	34, 51
Inlet.....	32, 41
Installation guide	47, 48
Installation Space	23
Interference	6
interlock	24
Interval Wiping.....	114
Ionizer.....	186, 187, 189

J

Jam sensor	30, 125, 133
[JOG] key	38
Judgment Condition	113

K

Key Buzzer	120
KeyLife	121

L

LAN cable	32, 44
LAN port	32
LANGUAGE	120
Light-blocking cover	34, 50, 166
List.....	122
Local guidance	40
LOCAL mode.....	38, 39
Logical Seek	118

M

Machine Status Menu.....	122
Main power switch.....	32, 37, 41
Maintenance	122
Maintenance cover	30
Maintenance History.....	122
Maintenance liquid absorber	148
Maintenance Menu	112
MAPS (Mimaki Advanced Pass System)	109
Margin	119
Mark Detect	180
Meander Recovery Action	114

Media.....	62
Media cutter.....	30
Media feed.....	38
Media feeding belt.....	30
Media Information.....	109
Media Name Change.....	111
Media Remain.....	110
Media Sensor.....	32, 36, 125, 132
Media Setting Menu.....	108
Media stopper.....	66
Media Width.....	109
MENU mode.....	39
Mimaki driver.....	47
MIST FILTER.....	125, 137, 153
MRA (Mimaki Remote Access).....	120

N

NCU (Nozzle Check Unit).....	35, 125, 130
Network.....	120
NOT-READY mode.....	39
Nozzle Check.....	112, 116
Nozzle clogging.....	89, 116
Nozzle Deflection.....	89
Nozzle Recovery.....	112, 114
Nozzle Wash.....	112, 163

O

Operating Panel.....	30, 38
----------------------	--------

P

PIN code.....	121
Platen.....	125, 134
Positioning bar.....	32
Power cable.....	41
Power lock roller.....	31
Power outlet.....	41
Power plug.....	41
Power Setting.....	118
Print Area.....	122
Print Length.....	122
Print Maint.....	113
Print origin.....	98

Print Take-up	118
Printing Check	112
Pullback printing	92
Pump Tube Cleaning	112, 132

R

RasterLink	47, 48, 96, 97, 119
Rear clamp roller	110
Rear switch	32
Receive buffer	100
Reference guide	97
Remaining ink	39
Remote Control	120
REMOTE mode	38, 39
Replace Wiper	112, 122, 142
Roll holder	67, 68
Roll Wiper Remain	122

S

[SEL] key	38
Sensor sensitivity	169, 177
Smoothing Level	109
Space Btwn PP.	119
Space Feed Mode	119
Station	30, 35
Station Maint.	112
Status lamp	38
Switching hub	44
Symbol Marks	8
SYSTEM HALT	38

T

Take-up SW	118
Take-up unit	30, 64, 118
Test Printing	38, 87, 112
Tightening tool	53
Time Set	120
Torque limiter	65

U

Unit Setting	120
Usage	122

USB interface cable.....	32, 45
USB port.....	32
Use Time.....	122
UV AdjVal.....	109
UV Lamp.....	122
UV mode.....	109
UV-LED lamp.....	109, 122, 128
UV-LED Unit.....	125, 154

V

Vacuum Fan.....	110
Version.....	122
View Feed.....	119

W

Warning Label.....	25
Waste Ink Tank.....	114, 122, 125, 150
White ink.....	88
White Maintenance.....	114
WhiteSpace Setting.....	119
Wiper.....	35, 112, 129, 142, 167
Work Change.....	110

Operation manual

July, 2026

MIMAKI ENGINEERING CO.,LTD.

2182-3 Shigeno-otsu, Tomi-shi, Nagano 389-0512 JAPAN

D203896-13-10072026

